

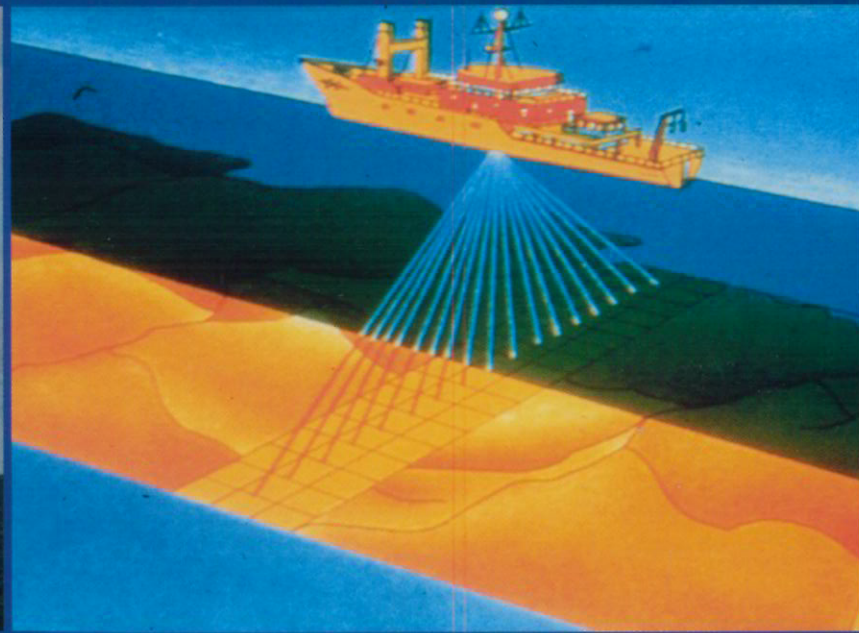

# Proposed Technologies for Deep Seabed Mining of Polymetallic Nodules



PROPOSED TECHNOLOGIES FOR  
MINING DEEP-SEABED  
POLYMETALLIC NODULES





# PROPOSED TECHNOLOGIES FOR MINING DEEP-SEABED POLYMETALLIC NODULES

Proceedings of the International Seabed Authority's  
Workshop held in Kingston, Jamaica  
August 3–6, 1999

Prepared by  
Office of Resources and Environmental Monitoring  
International Seabed Authority, Kingston, Jamaica

The designations employed and the presentation of material in this publication do not imply the impression of any opinion whatsoever on the part of the Secretariat of the International Seabed Authority concerning the legal status of any country, territory, city, or area or of its authorities, or concerning the delimitation of its frontiers or boundaries.

ISA/2001/07

All rights reserved. No part of this publication may be reproduced, stored in a retrieval system, or transmitted in any form or by any means, electronic, mechanical, photocopying or otherwise, without the prior permission of the copyright owner. Applications for such permission with a statement of purpose and extent of the reproduction, should be addressed to the Secretary-General, International Seabed Authority, 14-20 Port Royal Street, Kingston, Jamaica.

COPYRIGHT © INTERNATIONAL SEABED AUTHORITY, 2001

Reprinted with corrections 2007

Design: CAP Designs Ltd  
Pre-press: Tropiccolour Limited  
Printed in Jamaica by Lithographic Printers Ltd

# Table of Contents

FOREWORD		7
PARTICIPANTS		9
EXECUTIVE SUMMARY		13
<b>PART I</b>	<b>TECHNOLOGIES FOR DEEP SEABED EXPLORATION AND EXPLOITATION</b>	<b>33</b>
	INTRODUCTION	34
Chapter 1	<b>An Advanced Nodule Mining System</b> <i>Professor Dr. Ing Wilhelm Schwarz,</i> <i>Institute for Construction University of Siegen, Germany</i>	39
Chapter 2	<b>Nodule Collector Subsystems</b> <i>Professor Dr. Ing Wilhelm Schwarz,</i> <i>Institute for Construction University of Siegen, Germany</i>	55
Chapter 3	<b>Nodule Collector Subsystems</b> <i>Mr. Ted Brockett, President, Sound Ocean Systems Inc Redmond,</i> <i>Washington, DC. United States of America</i>	67
Chapter 4	<b>Fundamental Study for the Development of a Collector Subsystem and its Future Technological Needs</b> <i>Mr. Katsuya Tsurusaki, Japan Environmental Management Association for Industry, Tokyo, Japan</i>	95
Chapter 5	<b>Undersea Platforms and Vehicles – The IKS Crawler</b> <i>Professor Dr. Ing Wilhelm Schwarz, Institute for Construction University of Siegen, Germany</i>	117
Chapter 6	<b>Deep Seabed Mining - Undersea Platforms</b> <i>Dr. James Mcfarlane, International Submarine Engineering Ltd.</i> <i>Port Coquitlam, Canada</i>	133

Chapter 7	<b>Deep Seabed Mining - Lift Subsystems</b> <i>Professor Dr. Ing Wilhelm Schwarz, Institute for Construction University of Siegen, Germany</i>	153
PART II	<b>PRESENTATIONS BY THE REGISTERED PIONEER INVESTORS</b>	161
	<b>INTRODUCTION</b>	162
Chapter 8	<b>The Japanese Experience in Deep Seabed Exploration</b> <i>Dr. Kazou Shuto, Deep Ocean Resources Development Co. Ltd (DORD)</i>	167
Chapter 9	<b>An Environmentally-Friendly Deep Seabed Mining System</b> <i>Mr. Feng Liu, China Ocean Mineral Resources R&amp;D Association (COMRA) &amp; Mr. Ning Yang, Changsha Research Institute of Mining and Metallurgy (CRIMM)</i>	187
Chapter 10	<b>Scientific and Technological Research and Development Related to Deep Seabed Mining</b> <i>Mr. Guy Herrouin, Centre de Toulon La Seyne, IFREMER</i>	213
Chapter 11	<b>Japan's Nodule Collector Test on a Seamount</b> <i>Dr. Tetsuo Yamazaki, National Institute for Resources and Environment (NIRE), Tsukuba, Japan</i>	245
Chapter 12	<b>Research and Development of Deep Seabed Mining Technologies for Polymetallic Nodules in Korea</b> <i>Dr. Sup Hong, Ocean Development System Research Center &amp; Mr. Ki Hyune Kim, Deep Sea Resources Research Center, Seoul, Korea</i>	261
Chapter 13	<b>An Overview of the Indian Polymetallic Nodule Program</b> <i>Professor M. Ravindran, National Institute of Ocean Technology, Department of Ocean Development, India</i>	285
PART III	<b>OPPORTUNITIES FOR INCREASING THE GLOBAL MINERAL RESOURCES BASE FROM MARINE MINERAL DEVELOPMENT</b>	295
	<b>INTRODUCTION</b>	296

<b>Chapter 14</b>	<b>Atlantis II Deep: A Future Deep Sea Mining Site</b> <i>Mr. Zohair Nawab, Advisor, Ministry of Petroleum and Minerals, Jeddah, Arabia</i>	301
<b>Chapter 15</b>	<b>Terrestrial Mines in the Sea, Industry, Research &amp; Government</b> <i>Mr. Julian Malnic, Chief Executive Officer, Nantilns Corporation New South Wales, Australia</i>	315
<b>Chapter 16</b>	<b>Methane Hydrate Research and Development</b> <i>Mr. Michael Cruickshank, President MMTC Associates, Hawaii, USA</i>	333
<b>Chapter 17</b>	<b>New and Proven Mining Systems for Placer Deposits on the Continental Shelf</b> <i>Mr. Richard H. T. Garnett, President, Valrik Enterprise Inc., Ontario, Canada</i>	345
<b>PART IV</b>	<b>SCOPE FOR COOPERATION</b>	365
<b>Chapter 18</b>	<b>The Consortium Approach to Deep Seabed Mining</b> <i>Mr. Michael Cruickshank, President, MMTC Associates, Honolulu, Hawaii, USA</i>	367
<b>Chapter 19</b>	<b>Closing Remarks of the Secretary-General</b>	388
<b>Chapter 20</b>	<b>Conclusions and Recommendations</b>	392
<b>APPENDICES</b>		397
<b>Appendix A</b>	International Seabed Authority Fourth Session. Plans of work for exploration of the Government of India, Institut Français de Recherche pour l'exploitation de la mer (Ifremer)/ Association française pour l'étude et la recherche des nodules (Afernod) (France), Deep Ocean Resources Development Co. Ltd. (DORD)(Japan), Yuzhmorgeologiya (Russian Federation), China Ocean Minerals Research and Development Association (COMRA) (China), Interoceanmetal Joint Organization (IOM) (Bulgaria, Cuba, Czech Republic, Poland, Russian Federation and Slovakia) and the Government of the Republic of Korea. <i>Report of the Secretary-General ISBA/4/A/L/Rev. 2, September 3, 1998</i>	398
<b>Appendix B</b>	Polymetallic Nodules Database – POLYDAT - <i>Secretariat, ISA.</i>	447





## Foreword

In spite of some two decades of research and development in deep seabed mining activities, especially in relation to mining deep seabed polymetallic nodules, the technology required is still in its infancy. Despite periods of high enthusiasm, the development has been slow. There are a number of factors that have inhibited progress. Firstly, the hostile environment in which these activities take place both as regards the surface conditions and the great depths at which these activities are to take place. The second factor has been the design, development and adaptation of technology for seabed mining, which remains a major challenge. Thirdly, the costs involved in research and development, especially the cost of developing highly sophisticated technology that can operate efficiently at great depths, have been prohibitive. Fourthly, the economics of deep seabed mining of polymetallic nodules remains uncompetitive.

The evolution that has taken place in deep seabed mining activities is very interesting. In the sixties, seventies and eighties, major activities in this field were undertaken by private consortia in Japan, France and the Soviet Union being exceptions. From the late seventies into the eighties and nineties, the main actors have changed significantly. The activities of the four U.S. based consortia and those based in Germany and the U.K. have diminished. New actors have entered the field; these are India, China, and the Republic of Korea. Today the action has shifted markedly to the Asian region where seabed mining activities in terms of research and development, including the development of technology, are more active than elsewhere. While there has been a shift in actors, the geographical area of research and development activities largely remains the same.

The Clarion-Clipperton fracture zone in the northeast Pacific Ocean is still considered the site for first generation mining of polymetallic nodules. The activities of India are taking place in areas located in the South Central Indian Ocean.

What is also interesting is that various actors have done much work in research and development, particularly with respect to development of technology. They have been done independently of each other. That tendency seems to continue to the present day.

There is however, a considerable accumulation of knowledge and know-how that is not being effectively or efficiently utilized. There has been and continues to be a duplication of effort. The challenge for those engaged in seabed mining is how to harness the accumulated knowledge and build upon it as a means to accelerate seabed-mining activities. If this can be done there would be considerable cost sharing and indeed cost saving. More importantly, a collaborative effort will also help accelerate the development of technology. In its present state of infancy, seabed mining should not be seen as an exclusive activity, it should be seen as a new challenge to man's ingenuity in a new frontier which lends itself to a collective effort.

The workshop gathered some of the leading technologists and researchers in the world, whose work has been to develop cost-effective technologies for deep seabed mining. Their presentations shed light on this fairly mystic field. Also present were representatives of the pioneer investors who were registered as such with the Preparatory Commission. They would be the Authority's first contractors. Their work on technology development has been and continues to be the bedrock for the eventual exploitation of deep seabed polymetallic nodules. Their presentations especially indicate the work that they are doing in research and development of technology.

The purpose of this workshop was to learn about developments with respect to some of the crucial subsystems required for a cost-effective, integrated mining system and also to learn about the progress that has been made in exploration and exploitation technologies. It was also an opportunity to learn about the future plans of pioneer investors and the scope for cooperation among them and with others engaged in the marine minerals industry. Furthermore, it was an opportunity to learn from other operators and researchers in the marine minerals industries such as oil and gas, placer mining as well as emerging resources such as gas hydrates and seafloor massive sulphide deposits, technological developments in their industries that might find application in deep seabed polymetallic nodule mining. It was also an occasion to examine possible cooperative approaches to help resolve the remaining technological impediments to establishing a proven system for deep seabed polymetallic nodule mining.

Satya N. Nandan  
Secretary General  
International Seabed Authority  
Kingston, Jamaica

## Participants

*Mr. Dieuseul Anglade*, Director-General, Bureau of Mines and Energy, Port-au-Prince, Haiti, Email: [mines-energie@rehred-Haiti.net](mailto:mines-energie@rehred-Haiti.net) or [dsanglade@hotmail.com](mailto:dsanglade@hotmail.com)

*Ms. Frida Armas-Pfirter*, Coordinator, National Commission on the Outer Limit of the Continental Shelf, Buenos Aries, Argentina, Email: [fza@mrecic.gov.ar](mailto:fza@mrecic.gov.ar)

*Prof. Arne Bjørlykke*, Director General, Geological Survey of Norway, Trondheim, Norway, Email: [Arne.Bjorlykke@ngu.no](mailto:Arne.Bjorlykke@ngu.no)

*Ms. Stephanie Brockett*, Secretary/Treasurer, Sound Ocean Systems, Inc, Redmond, WA, United States of America, Email: [Steph@Soundocean.com](mailto:Steph@Soundocean.com)

*Mr. Ted Brockett*, President, Sound Ocean Systems, Inc, Redmond, WA, United States of America, Email: [Ted@Soundocean.com](mailto:Ted@Soundocean.com)

*Professor Helmut Beiersdorf*, Bundesanstalt Für Geowissenschaften und Rohstoffe, Hannover, Federal Republic of Germany, Email: [beiersdorf@bgr.de](mailto:beiersdorf@bgr.de)

*Dr. Michael Cruickshank*, President, MMTA Associates, Hawaii, United States of America, Email: [mcruick@aol.com](mailto:mcruick@aol.com)

*Mr. Baidy Diene*, Special Adviser to the Minister, Ministry of Energy, Mines and Industry, Dakar, Senegal, Email: [memisen@sonatel.senet.net](mailto:memisen@sonatel.senet.net)

*Dr. Esteban Morales Gamboa*, Dean, Faculty of Natural Resources, Universidad Catolica de Valparaiso, Valparaíso, Chile, Email: [emorales@ucv.cl](mailto:emorales@ucv.cl)

*Dr. Richard Garnett*, President, Valrik Enterprise Inc., Ontario, Canada, Email: [Valrik@interlog.com](mailto:Valrik@interlog.com)

*Mr. Guy Herrouin*, Director, Centre de TOULON- IFREMER, La Seyne, France, Email: [guy.herrouin@ifremer.fr](mailto:guy.herrouin@ifremer.fr)

*Dr. Sup Hong*, Principal Research Engineer, Korea Ocean Research and Development Institute, Korea Ocean Research of Ships and Ocean Engineering, Taejon, Republic of Korea, Email: [suphong@kriso.re.kr](mailto:suphong@kriso.re.kr)

*Dr. Trevor Jackson*, Senior Lecturer, Department of Geography & Geology, University of the West Indies, Kingston, Jamaica, Email: [tjackson@unmona.edu.jm](mailto:tjackson@unmona.edu.jm)

*Mr. Jean-Pierre Lenoble*, Legal & Technical Commission (ISA), France, Email: [lenoble@ifremer.fr](mailto:lenoble@ifremer.fr)

*Mr. Feng LIU*, Assistant Secretary-General and Director, Programme Division (COMRA), Beijing, People's Republic of China, Email: [fliu@cenpok.net](mailto:fliu@cenpok.net)

*Mr. Juan Pablo Vergara Loboguerrero*, Naval Attaché, Colombian Embassy of Jamaica, Kingston, Jamaica, Email: [agrejam@cejamaica.com](mailto:agrejam@cejamaica.com)

*Professor Elizabeth Mann-Borgese*, International Ocean Institute (IOI), Dalhousie University, Halifax, Canada, Email: [eborgese@dal.ca](mailto:eborgese@dal.ca)

*Mr. Julian Malnic*, Chief Executive Officer, Nautilus Minerals Corporation, New South Wales, Australia, [julian@seax.com.au](mailto:julian@seax.com.au)

*Mr. Sheldon A. McDonald*, Deputy Permanent Representative of Jamaica to ISA, Attorney-General's Department, Kingston, Jamaica,

*Dr. James R. McFarlane*, President, International Submarine Engineering Ltd., Port Coquitlam, Canada, Email: [info@ise.bc.ca](mailto:info@ise.bc.ca)

*Dr. Nahgeib Miller*, Geologist, Mines and Geology Division, Kingston, Jamaica, Email: [Mgd@wtjam.net](mailto:Mgd@wtjam.net)

*Mr. José H. Monteiro*, Senior Research Officer, Instituto Geologico e Mineiro, Alfragide, Portugal, Email: [hipolito.monteiro@igm.pt](mailto:hipolito.monteiro@igm.pt)

*Mr. Samir Mutwalli*, Director, Deputy Minister's Office, Ministry of Petroleum and Mineral Resources, Jeddah, Saudi Arabia, Email: [Samutwalli@YAHOO.com](mailto:Samutwalli@YAHOO.com)

*Dr. Zohair A. Nawab*, Advisor, Ministry of Petroleum & Minerals, Jeddah, Saudi Arabia

Mr. *Kyung-ho Park*, Principal Researcher, Korea institute of Geology, Mining & Material, Taejon, Republic of Korea, Email: [khpark@kigam.re.kr](mailto:khpark@kigam.re.kr)

Mr. *Jonathan P. Richards*, Political Unit, Greenpeace International, Amsterdam, Netherlands, Email: [j.prichards@plymouth.ac.uk](mailto:j.prichards@plymouth.ac.uk)

Mr. *Giovanni Rosa*, Manager, SAIPEM SpA, Milan, Italy, Email: [Giovanni.rosa@saipem.eni.it](mailto:Giovanni.rosa@saipem.eni.it)

Professor *Wilhelm Schwarz*, Professor, University of Siegen. Siegen, Germany, Email: [iksft@dsmt\\_715.ik.mb.uni.siegen.de](mailto:iksft@dsmt_715.ik.mb.uni.siegen.de)

Dr. *Kazuo Shuto*, Counsel of Exploration, Deep Ocean Resources Development Co. Ltd., Tokyo, Japan, Email: [otcl@dord.co.jp](mailto:otcl@dord.co.jp)

Mr. *Alfred Simpson*, Director, South Pacific Applied Geoscience Commission, (SOPAC), Suva, Fiji, email: [alf@sopac.org.fj](mailto:alf@sopac.org.fj)

Mr. *Ismat Steiner*, Director, DOALOS/OLA, United Nations, New York, United States of America, Email: [Steiner@un.org](mailto:Steiner@un.org)

Mr. *George P. Stewart*, Consultant, Ministry of Foreign Affairs, Nassau, Bahamas, [Gstewart@bahamas.net](mailto:Gstewart@bahamas.net)

Dr. *Katsuya Tsurusaki*, General Manager, Environmental Technology Department, Japan Environmental Management Association for Industry, Tokyo, Japan, [Tsuru@jamai.or.jp](mailto:Tsuru@jamai.or.jp)

Dr. *Isabelle Van Tol*, Second Secretary, Royal Netherlands Embassy, Kingston, Jamaica, [Rnekst@cwjamaica.com](mailto:Rnekst@cwjamaica.com)

Mr. *Zhu Wenxi*, Department of International Cooperation, State Oceanic Administration, Beijing, People's Republic of China

Mr. *Boris Winterhalter*, Senior Marine Geologist, Geological Survey of Finland, Espoo, Finland, Email: [boris.winterhalter@gsf.fi](mailto:boris.winterhalter@gsf.fi)

Mr. *Tetsuo Yamazaki*, Senior Researcher, National Institute for Resources & Environment, Ibaraki, Japan, Email: [p1810@nire.go.jp](mailto:p1810@nire.go.jp)

## Secretariat

Ambassador Satya N. Nandan, Secretary-General, International Seabed Authority, Kingston, Jamaica, Email: [SNandan@isa.org.jm](mailto:SNandan@isa.org.jm)

Mr. Nii Allotey Odunton, Deputy to the Secretary-General and Chief, Office of Resources and Environmental Monitoring, International Seabed Authority, Kingston, Jamaica, Email: [nodunton@isa.org.jm](mailto:nodunton@isa.org.jm)

Mr. Anthony T. Jones, Scientific Affairs Officer (Marine Biology), International Seabed Authority, Kingston, Jamaica, Email: [TJones@isa.org.jm](mailto:TJones@isa.org.jm)

Mr. Kaiser DeSouza, Scientific Affairs Officer (Marine Geology), International Seabed Authority, Kingston, Jamaica, Email: [Kdesouza@isa.org.jm](mailto:Kdesouza@isa.org.jm)

Mr. Jean-Baptiste Sombo, Information Technology Officer, International Seabed Authority, Kingston, Jamaica, Email: [JBSombo@isa.org.jm](mailto:JBSombo@isa.org.jm)

Mr. Ricardo Gonzalez, International Seabed Authority, Jamaica

Ms. Margaret Holmes, International Seabed Authority, Kingston, Jamaica, Email: [Mholmes@isa.org.jm](mailto:Mholmes@isa.org.jm)

Mrs. Charmaine Henney, International Seabed Authority, Kingston, Jamaica, Email: [Chenney@isa.org.jm](mailto:Chenney@isa.org.jm)

## Executive Summary

The workshop on Proposed Technologies for Deep Seabed Mining focused, in its conception, on progress to date on the development of technologies for the exploration and exploitation of deep seabed manganese nodules. During the planning process, however, it became apparent that the ubiquitous nodules, though not neglected, were no longer the only mineral deposits of interest in the Area. Cobalt crusts, metalliferous sulfides, fluid hydrocarbons, sands, and, more recently, gas hydrates have been the subject of intensive research and discussion among government and academic institutions and resource-oriented industries. The final structure of the workshop was built around four issues presented in four parts: Part I, Technologies for deep seabed exploration and exploitation, focusing mainly on generic issues in deep seabed minerals technology; Part II, Presentations by registered pioneer investors on the progress they had made in developing their technologies for mining manganese nodules, problems they have encountered, and their future plans; Part III, Challenges that lie ahead relating to minerals other than manganese nodules; and, finally, Part IV, The scope for cooperation among the varied interests in government, academia, and industry.

The workshop was held at the headquarters of the International Seabed Authority at Kingston, Jamaica from August 3 through August 6, 1999. During these four days, 21 formal presentations were made and a great deal of valuable discussion and interaction took place among the 36 participants and the Secretariat. A unique aspect of this gathering was the almost complete participation of technical representatives of the pioneer investors. All seven registered pioneer investors were invited to the workshop and those present were IFREMER of France, DORD of Japan, KORDI of Korea, COMRA of China and DOD of India. YUZMORGEOLOGIA of the Russian Federation and the IOM led by Poland unfortunately could not attend, but the presence of other experts familiar with the early industrial activities in the Clarion-Clipperton Fracture Zone (CCZ), as well as more recent developments in other parts of the world, resulted in the compilation of much valuable information not previously recorded, and which otherwise might have been lost. For this reason, the discussions which followed each presentation are fully summarized in the proceedings.



In relation to their future plans, the Secretariat requested that the registered pioneer investors also inform the workshop of the scope that exists for cooperation, whether in the form of cooperation among themselves, or with independent research institutions and other kinds of researchers. This was amply discussed during the final part of the session.

### **Technologies for Deep Seabed Exploration and Exploitation**

In speaking of an **advanced nodule mining system**, *Professor, Dr. Ing Wilhelm Schwarz*, of the Institute for Construction, University of Siegen, discussed the history of commercial mining systems, particularly those of the French GEMONOD and the German Preussag collaboration with the consortium Ocean Management Incorporated (OMI). This group tested active collectors with submerged hydraulic pumps and, like most of the programs of that time, based their economics on a minimum 3 million ton/year operation for the three metals copper, nickel and cobalt. He suggested that traditional and nationalistic competitive thinking led to these proposals for gigantic operations that had little chance for success. In collaboration with the government of India, the University recently developed plans for a more realistic and advanced system which incorporated three new concepts: 1. A fleet of small, low cost, mobile, mining vessels to work as satellites around a "mother ship"; 2. mining equipment that could be easily de-coupled and re-coupled at the surface for protection and safety in the event of severe weather; and, 3. environmentally benign, or "soft" mining equipment that would not adversely impact the biological environment. Some of the components of the advanced system, that the speaker described, had already been tested successfully in shallow water near to the Indian Ocean pioneer mine site.

Three experts, from Germany, USA, and Japan, each discussed **nodule collector subsystems**. *Professor Schwarz* affirmed that active collectors were superior to passive collectors because the risk of clogging was much reduced. He described the first OMI collector with which he had worked that resembled a potato harvesting machine, but after testing it was apparent that some form of washing of the nodules was essential. This led to the development of the hybrid collector with water jet assist for loading and washing. The hybrid machine disturbed too much sediment and further design led to the development of an improved, strictly mechanical, walking-beam comb device that was self cleaning. The speaker was of the opinion that the introduction of improved and smaller, scale systems would result in lower costs and break-even economics for the nodules in the very near future. His premise included operations in the Indian Ocean, leased barges and other transportation facilities, and custom treatment of the ores.

*Mr. Ted Brockett*, CEO of Sound Ocean Systems in Seattle, thoroughly detailed, by video and slides, his experiences in 1978 of Ocean Management Inc's (OMI) laboratory and deep seabed testing operations to compare some eight different collectors. Passive collectors tested included a rhomboid rake, a hybrid passive rake using a wash and transport water intake powered by the forward movement of the machine, and a passive inverted flow system which planed off and cleaned the first ten cm or so of the deposit. In general, he said, the passive systems are simple but unacceptable, largely because the sediments are cohesive and stick to the nodules and the machines forming massive bow waves. When added to the energy required for pick up, these characteristics of passive collectors result in significant loss of nodules in the sediment masses that are by passed by the collector.

Examples of active mechanical and hybrid concepts tested included a mechanical drum, a mechanical ramp, an hydraulic ramp, an hydraulic plow and an hydraulic lift.

The purpose of the collector is to gather nodules and deliver them, bereft of sediment, to the intake of the vertical transport system. Of the designs tested, the simple rake, and the hydraulic ramp and lift appeared to offer the most potential as simple commercial systems. The two mechanical concepts had very high collection efficiencies but many moving parts and required separate subsystems for sediment removal.

For a commercial system, collector width is a critical factor and is a function of nodule coverage, ship speed, collector efficiency and anticipated operating time, which for OMI, was based on an annual production of one million dry short tons. The speaker briefly discussed traction devices which included towed skids, wheels, tracks and Archimedes screws.

The speaker suggested that all systems should be thoroughly tested on land at pilot and prototype scale before submitting them to the high cost of testing in situ. He noted that pilot mining tests at sea are, however, the only way to determine the effectiveness of the total system. With the advancement of technology over the past twenty years, it is easier today than ever before, the speaker said, to accomplish the required tasks necessary to successfully mine the sea floor.

*Mr. Katsuya Tsurusaki*, from the Japan Environmental Management Association for Industry, reviewed the development of nodule collector subsystems. Their performance and design is strongly affected by the geotechnical properties of the sediments and of the nodules, both of which he reviewed in detail. These relationships were discussed with reference to the Japanese collector development and the deep seabed mining test conducted in 1997.

Two cases were examined specifically for the towed-sled hydraulic collector. One for the towing action, which included the resistant forces caused by frictional drag, the rejection of molded sediment in front of the collector, and the adhesive qualities of the sediment. The other for the very sensitive moment of touch down of the collector on the seabed. A new method was developed to measure the modulus of elasticity and the viscosity of the sediments. The collector test, which was described later by Mr Yamazaki, was carried out on a sea mount at a depth of 2200m. In this area, the nodule density was 15.6 kg/m<sup>2</sup> and was distributed on thin foraminiferous sediments much different from the deep seabed. The test was successfully conducted, over a towed distance of 535 m with a pickup efficiency estimated at 87%. The importance of collector efficiency to a successful mining operation was stressed. There are two ways to improve this, he asserted, to increase sweep efficiency and to reduce downtime. Future collector development should include a self-propelled mechanism with obstacle avoidance, extreme reliability of components and instruments, to obviate the need for retrieval of the collector, and a control buffer between the collector and the vertical lift.

**Undersea platforms and vehicles** were discussed by two experts. *Professor Schwarz* outlined the basic requirements for ground impacting vehicles. He briefly described the various types appropriate for nodule mining including: towed sleds, contra-rotating Archimedean screws and tracked vehicles, the latter being, to his understanding, the only kind presently favored for mining. Design restrictions imposed by soil characteristics are significant and there are some areas completely unsuitable for the passage of crawlers. In most deep seabed areas, below an extremely soft, semi liquid layer of about 5-10 cm thick, there is a cohesive soil. The soil is trafficable, by definition, if its shear strength is not lower than 2.5 kPa measured with a vane tester according to DIN 4096. The speaker described a crawler vehicle with toothed tracks designed for the Indian Ocean programme but yet to be built and tested.

*Dr. James McFarlane*, of International Submarine Engineering Ltd. in Canada, made a very excellent and detailed slide presentation in review of submarine vehicles of the past, present and future. His talk focused on the state of development of sub-sea platforms to deliver tools and sensors to the sea, or, more specifically, on ROVs, AUVs and towed systems. "We predict the future", he said, "by considering the past and the present". The 1960s was a time of very rapid changes in capabilities. In 1960 Walsh and Piccard dived to the bottom of the Challenger Deep at a depth over 11,000 meters; President John Kennedy, elected that year, proclaimed, perhaps prophetically, "A knowledge of the oceans is more than a matter of curiosity, our very survival may depend upon it!" The ROVs, AUVs and towed systems of today are a legacy of that robotic revolution.

Sub-systems development is now very mature and all kinds of exploration equipment can work in the deepest parts of the ocean.

Various **lift subsystems** were discussed by *Professor Schwarz* who indicated that after many tests and much expensive research and development (R&D) the primary choices for seabed mining were air lift and hydraulic pumps, both of which had been tested in situ by OMI. Subsequent work by NIOT in India and IKS in Germany, however, has suggested advantages in using a bottom-sited pump with a lock-chamber nodule feed on the discharge side of the pump. The most important advantage of this was the opportunity to eliminate any negative pressure in the riser system and be able to substitute a flexible fire-hose-type riser instead of rigid steel for the full lift to the surface. Further refinements of this concept resulted in the design of a computer-controlled, non-pulsed-flow piston pump, fed by a crusher to eliminate oversize pieces that might have a potential for blockage. With this type of system, control of the bottom machinery would be more flexible and the ability to apply quick release and recovery of the hose on surface would be enhanced.

### **Presentations by the Registered Pioneer Investors**

Speakers from Japan, China, France, Korea, and India gave presentations on the accomplishments of their respective national R&D programs relating to manganese nodule development in the Area, and included some plans and concepts for future work.

The **Japanese Experience in Deep Seabed Exploration** was described by *Dr. Kazou Shuto*, of Deep Ocean Resources Development Co. Ltd, (DORD). He outlined the work carried out in prospecting for nodules which was characterized as the "progressively closer prospecting method". Target areas were characterized on a square grid of 42.4 nautical miles and subsequently in more detail on a grid of 21.2 nautical miles. Navigation was by the Global Positioning System (GPS). Geological sampling equipment at grid points included free-fall grab, spade corer, and piston corer aided by sampler mounted cameras and a continuous deep sea camera for visual continuity between sampling stations. Geophysical surveys were carried out using a 3.5 kHz sub-bottom profiler, an 8-15 kHz precision depth recorder, a 25-35 kHz narrow beam echo sounder and a multi-frequency exploration system (MFES). The MFES provides a continuous flow of information on nodule distribution and density between the sampling stations as well as being used for reconnaissance surveys. The MFES synthesizes the data from each of the instruments using a digital format and correcting for water depth. It was suggested that this combined system may provide a more accurate estimate of nodule abundance than sampling by itself.

*Liu Feng and Ning Yang*, discussed an **Environmentally Friendly Deep Seabed Mining System** under development by the China Ocean Mineral Resources R&D Association, (COMRA).

This is defined as a system that will not produce serious harm to the marine environment, with the same objectives as the “soft” mining system introduced by Professor Schwartz. Four major systems have been conceived, or tested, in the last thirty years; the continuous line bucket (CLB), the passive towed collector, the active self-propelled collector and the submarine shuttle. The ideal system needs to be environmentally friendly, efficient in utilization of the natural resources, and highly reliable in operation.

The principal impacts identified are: seabed disturbance by the miner, spillage due to a vertical transport riser pipe failure, and surface tailings discharge. These lead to design principles based on the pickup and transport of clean nodules without sediment, the fastest possible bottom plume settling rate to minimize burial of adjacent nodules, and the selection of optimal miner tracks based on topography and currents to carry the plume away from unworked ground.

The weight of the collector should be minimized to prevent its sinking into the soft sediment, pipe size should be such to prevent jamming and waste water should be discharged at a depth least likely to create negative impacts.

Other design criteria include an optimum collector width and high pickup efficiency. The system should be reliable and use as many industrially proven technologies as feasible. COMRA developed two collector types, a hybrid collector, and a hydraulic collector, both on caterpillar tracks, one with a mechanical and the other with a water jet pickup using a Coanda nozzle. A flexible hose between the connector and a buffer on the main lift was considered critical. No field tests have yet been carried out but are planned. COMRA’s positive views on technology development through international cooperation are detailed and are discussed in Part IV.

The work completed and underway in France on **Scientific and Technological R and D related to Deep Seabed Mining** was presented by *Mr. Guy Herrouin*, of AFERNOD/IFREMER. *Mr. Herrouin* stated that this group has performed extensive studies to determine the characteristics of nodule mining including exploration, mining feasibility and economics, as well as scientific and technological R&D in the deep sea on an international basis. Their joint policy is to promote and perform generic research and development in this field and acquire the capability to apply the results to deep sea mining operations when the time comes. The two organizations have worked together since

1971, and became registered as a pioneer investor in 1987. They have expended more than 1 billion Francs on R&D, and joint cruises to study nodules, crusts, sulphides and equipment development.

Based on work completed, using the CLB system, which they tested extensively, they came to the conclusion that this system was much hampered by rough bottoms, that the Archimedes screw was not good, that the caterpillar track was much better, that slopes greater than 12% were unminable and that avoidance systems were a necessity. Their general conclusions with regard to nodules indicate that mining operations would be marginally profitable, with a minimum capacity of 1.5 million dry tonnes per year, employing a self-propelled collection device in selected areas of high abundance.

The speaker noted that mining, transport and processing operations would need to be conducted at a high efficiencies and would have to incorporate a buffer with a flexible riser. The cost of a one-tenth scale pilot mining operation is too high for a single private investor, the speaker said.

The future plans of AFERNOD/IFREMÉR includes more detailed characterization of the seabed environment and the nodule interface, to determine, for example, the lifting force required to pick up nodules. Their future plans also called for cooperating closely with other pioneer investors and workers in the field of deep oil technology.

Environmental impacts, including those on ecosystems and caused by natural hazards such as weather and seabed instability, have become critical factors in their planning. From their experience to date, however, they believe it is more appropriate to study the dynamics of ecosystems rather than to pursue more of the large-impact studies (see also Thiel et al, 1997, Ed.).

The speaker concluded by indicating that prime candidates for adaptive technology from the deep-water petroleum industry, and represented in France by the French Petroleum Institute (IFP), are risers, flexible pipe, multiphase-flow pumps, handling systems, and floating production, storage and offloading vessels (FPSOs).

**Japan's Nodule Collector Test on a Seamount** was described by *Dr. Tetsuo Yamazaki*, of the National Institute for Resources and Environment (NRIRE) at Tsukuba, Japan. The successful large-scale test took place in 1997 following the completion of a 17-year national R&D program on nodule mining systems. There were four objectives of the test: verification of nodule pick-up performance; investigation of the dynamic behaviour of the collector during landing, towing and recovery; testing of peripheral systems including a hybrid cable carrying fibre optics and

power, and data transmission and underwater positioning systems; and preliminary measurements of environmental impact. The collector, with a pick up width of one meter, was towed by wire rope at a depth of 2200 m on a seamount in the Marcus-Wake region of the Pacific. Towing speed fluctuated between 0.3 and 0.8 knots.

Nodule abundance was 15.6 kg/m<sup>2</sup> and the average diameter of the nodule was 15 mm. The test covered 535 m in four legs and resulted in the production of 7.25 tons of nodules with an estimated collector efficiency of 87%. The Coanda effect was utilized in the pickup mechanism and the efficiency did not appear to be affected by slight variations in the pitch angle of the tow or of the nozzles.

Post-mining observations were carried out after one month from a commercial ROV using DGPS with a super-short baseline and video and photo imagery. Observations were made of areas of collector landing, nodule pick-up and collector take-off. One year after the test detailed side scan images, from an elevation of 40-50 m and photo images from an elevation of 3m, were obtained and used successfully to confirm the test results. Further improvements for the development of commercial mining will be continued on the basis of this work if necessary, the speaker said.

**R & D of Deep Seabed Mining Technologies for Polymetallic Nodules in Korea** was the subject of the presentation by *Dr. Sup Hong* of the Ocean Development System Research Centre and *Mr. Kyung-ho Park*, of the Deepsea Resources Research Centre, both of the Korean Government.

Korea's entry to this field began in 1994 upon registration as a pioneer investor. Investment obligations in exploration were carried out by the Korean Ocean Research and Development Institute (KORDI) on behalf of the Ministry of Maritime Affairs and Fisheries (MOMAF). Research and development in technologies for exploration and exploitation are supported by the Ministry of Science and Technology (MOST) in a planned 10-year programme continuing through 2003. Manganese nodule exploration technology is being developed by KORDI, nodule collector and integrated recovery systems technology is being developed by the Korea Research Institute of Ships and Ocean Engineering (KRISO), and lift technology is being developed by the Korea Institute of Geology, Mining and Materials (KIGAM). Joint research with other institutions, universities and industry in Korea and overseas have been encouraged and led to much progress during the initial stages.

Much of the effort has now focussed on the mandatory relinquishment of 50% of the 150,000 km<sup>2</sup> of the Registered Pioneer site by 2002. Besides the inten-

sive exploration effort to maintain a 5 km grid, the work includes studies on the environment in the area and its natural variations. Advanced exploration technologies being studied include high quality data acquisition, interpretation techniques, new technology applications, and cost effective survey systems.

The work on exploitation technology has focused on systems needed for full commercial mining in 2010 or later and include feasibility studies, concept system design and design of selected primary subsystems. The Korean concept design is based on enhancement of existing subsystems which include a self-propelled collector with flexible umbilical, enhanced buffer functions, and a conventional lift system. Innovative computer modelling has been extensively utilized in the design of the collector vehicle, pick-up device, two- and three-phase lift technology, mining operations, buffer position control, dynamic positioning and route tracking for the mining vessel, and dynamic simulation of the vessel and the tracked vehicle. Future plans are to increase international cooperation in the development of a commercial mining system and the government is planning a second long-term programme to this end.

*Professor M. Ravindran*, Director of the National Institute of Ocean Technology in Chennai, India, prepared the paper "**An Overview of the Indian Polymetallic Nodule Programme**". Since he could not be present for the workshop, the paper was presented by His Excellency O.D. Gupta, High Commissioner of India to Jamaica. His Excellency, Mr. Gupta informed the workshop that the Indian Polymetallic Nodule Programme is one of the major R&D efforts in India directed toward the development and use of marine non-living resources for the socio-economic benefit of the society. In 1981 the first samples of nodules were collected from the Indian Ocean Basin, beginning a programme that resulted in India's recognition as the first Registered Pioneer Investor in 1987, along with Japan, France and the Soviet Union.

The speaker further informed the workshop that Indian efforts have been directed in four areas: survey and exploration, mining technology, extractive metallurgy, and environmental impact analysis. The speaker said that India has already relinquished 20% of the area and has another 10% ready.

Close grid surveys at 5 km spacing are now planned to demarcate the mining areas and to estimate resource potential. Mining technology has been advanced on a model scale and a remote crawler system with a crusher and hydraulic transport for 100 tonnes/day has been built and tested in shallow water.

Mr. Gupta noted that more recent joint activities with the University of Seigen, in Germany, have resulted in the design of a superior mining system which



will be tested in deeper water. This system, he informed participants, was earlier described by Professor Schwarz.

In relation to extractive metallurgy, Mr. Gupta informed the workshop that as early as 1984 studies were begun on the recovery of copper, nickel and cobalt from nodules found in the Indian Ocean Basin. After studying about 15 processing options, the hydrometallurgical method was selected as the most appropriate route. Subsequently, this was again narrowed to the development of a sulphur dioxide ammonia leach. An operating plant is now being established by Hindustani Zinc at Udaipur.

On the environmental side, Mr Gupta stated that a long-term study was being undertaken in three phases in the Central Indian Basin. The first was a baseline study, the second an imposed disturbance using a hydraulic disturber, and the third a time-related study of the impacts on the ecosystems disturbed. The speaker indicated that the viability of industrial operations in terms of technology and operations is not yet established and major emphasis is now being given to innovative design that will reduce costs and increase reliability.

### **Opportunities for Increasing the Global Mineral Resource Base from Marine Mineral Development**

Polymetallic nodules have been a prime driver in Law of the Sea affairs since 1958 when Dr. John L. Mero, a mining engineer at the Hearst School of Mines in the University of California, Berkeley, first published an economic discourse on their vast potential as sources of manganese, cobalt, copper and nickel. Soon after, Arvid Pardo, the United Nations delegate for Malta proposed that the resources of the seabeds in the Area, beyond national jurisdiction, be declared "The Common Heritage of Mankind".

Forty years later, the nodules are still an economic driver but other resources have been recognized in the deep seabeds, and new technologies have been developed elsewhere, that demand the attention of the Authority.

Natural gas hydrates may be the most recent of the discoveries to make headlines and *Dr. Michael J. Cruickshank*, President, MMTC Associates, USA, presented a brief outline on **Methane Hydrate Research and Development** in the United States. A crystalline member of the oil and gas family, the hydrates are solid ice-like substances composed of water and gas, discovered in their natural state only about 30 years ago.

One cubic centimetre of hydrate will yield about 160 cubic centimetres of gas and about 0.87 cc water at STP. They occur in areas of the world that are prospective for petroleum and where gas and water can combine under appropriate conditions of temperature and pressure. These conditions are found in Arctic regions of permafrost, in deep-water basins adjacent to continental shelves, and in deep-ocean basins where the sediment thickness is at least one kilometre. Their widespread occurrence in the world's oceans and seas, their ability to change phase from solid to gas when disturbed, and other characteristics, has resulted in the recognition of four distinct areas in which more information is urgently needed. These are: their potential as an energy resource; their hazardous influence on seafloor stability when disturbed by activities such as drilling for oil and gas; their potentially serious influence on global climate; and the implications of indicated unique acoustical properties.

The immense volumes of gas, and the richness of selected deposits make methane hydrates a strong candidate for development as an energy resource. Recent studies by the United States Geological Survey have conservatively estimated deposits of this material worldwide to represent an untapped source of hydrocarbon energy-twice the amount to be found in all known fossil fuels on earth. The mean value of the estimates of methane contained in U.S. hydrate resources alone (320,000 trillion cubic feet) would supply all U.S. energy needs at the present rate of consumption for 64,000 years. Scientists and others urge caution, however, as the recoverability of gas from deep marine structures is very problematic at this stage.

While the published estimates of abundance are enormous, it is likely that most of the hydrate occurs in low concentrations and has no commercial potential. Nevertheless, the importance of natural hydrates in the global human environment appears to be well demonstrated. The possibility of major economic and environmental effects resulting from natural causes or human disturbance indicates a significant need to focus on the unknown characteristics of this vast resource to enable it to be used to the benefit of mankind.

In the USA, the Methane Hydrate Research and Development Act of 2000 authorized government expenditures of \$47 million over the next five years. India, Japan, and Canada have ongoing programs of R&D. For the ISA, it is an indication that hydrates should now be under serious consideration when formulating rules and regulations for management in the Area.

Giving a fresh look at recent advances in technology for seabed mining, *Dr. Richard H.T. Garnett*, President, Valrick Enterprises Inc, Canada, addressed the subject of **New and Proven Mining Systems for Placer Deposits on the**

**Continental Shelf** and focused specifically on the marine diamond industry of southern Africa. During the last decade the industry has provided the context for the development of new placer mining systems for the continental shelf. These are now proven and constitute the foundation for an increasing annual production of gem quality diamonds, soon to exceed that from onshore sources.

The deposits are derived from the Orange River alluvium and have been transported, sorted and concentrated along the coast by high-energy wind and sea conditions. Mining initially began in 1964, but was discontinued because of high costs and inadequate technology. Production on a large scale by De Beers commenced in 1989 in Namibian waters and the company now acts as a contractor to Namdeb, a corporation owned jointly with the Namibian Government. Other smaller public companies also produce diamonds and conduct extensive exploration programmes.

Two important developments have occurred. Equipment from other industries has been successfully adapted for seabed diamond recovery. Large drills from onshore civil engineering works have been modified for marine sampling and mining, and remotely-controlled, bottom-sited, seabed excavation systems have assumed a major role. Sampling and mining can be undertaken with the same equipment to give compatible results. Track and skid-mounted designs permit highly selective extraction and enhanced recovery of the diamondiferous gravel from irregular bedrock in waters as deep as 200 m.

Grade and throughput rate are the most variable inputs in operational planning and production forecasting. The importance of reliable grade estimation is widely perceived but the greatest performance risk involves the predicted mining rate, and "digability" (ease of digging) of the diamondiferous gravels. Despite the wider choice of mining systems now available, the speaker said, none is universally applicable offshore. Trial mining should be a part of any feasibility study; and published reserves statements should not only specify the proven mining system to be used but should be presented in language according to accepted international standards.

*Dr. Garnett* spoke also on the **Estimation of Marine Mineral Reserves**, a complex but exceedingly important subject that is rarely understood outside of the minerals industry. Reserve estimation is a process that commences with sampling and culminates in the issuance of a reserves statement. The presentation was focused on granular, or placer mineral deposits, particularly tin, gold and diamonds that occur as marine placers on the continental shelf. They are generally low grade with erratic mineral distributions. Sampling, using a variety of special equipment, determines the extent and the grade of the mineralization. Sample size is

important, especially for diamonds, as the accuracy of the grade estimate is based on that and the sample density. Bulk sampling, or pilot mining, is a confirmatory process, which combined with the sampling data, dictates the choice of mining equipment, unit costs, cut-off grades and the selectivity of extraction. The size of the blocks to be mined, and the reserves, are thus determined. A variety of estimating methods of differing reliability are available, the most sophisticated being Kriging. Dilution and losses during mining must be taken into account in estimation and a grade-volume curve should be constructed. Unlike the metals, diamond deposit estimation involves an extra variable, the dollar value of the individual stones based on their quality.

During and after mining, essential feedback on the accuracy of the estimates may be given by the R/E (Recovery/Expected Recovery) factor and by a mineral balance. Reserve estimates are required for several reasons and may be subject to public disclosure and audit. The use and understanding of the correct definitions is, therefore, very important.

Following from his two previous discussions, *Dr. Garnett* presented a third paper on **Mineral Recovery Performance in Marine Mining** in which he discussed the effects of various factors, some of them outside of the operator's control.

Recovery performance may be measured in absolute, or relative, terms that relate the actual mining outcome to that predicted. The eventual mineral output is the only figure known with complete certainty. The paradox is that while performance is judged against the sampling, the reverse is also true. The choice of equipment for sampling and mining is very important. The sampling process may introduce errors and the wrong choice of sampling density may lead to poor mining block selection. The resulting recovery performance is best illustrated by regression curves.

Changes in cut-off grade must also be taken into account to avoid unrealistic production targets. Estimation methods incorporating different mathematical assumptions and techniques may result in over- or under-estimation of the grade and volume. If the selective ability of the mining equipment does not match the size of the reserve blocks, the performance will be compromised.

The treatment plant efficiency, the throughput rate, and the degree of cleanup of the bedrock also affect performance. The maximization of throughput does not necessarily yield optimum results and marine and weather conditions affect both downtime and performance. The speaker showed examples of the relative magnitude of different effects on performance, taken from actual operations.

A world's first in marine minerals was discussed by *Mr. Julian Malnic*, CEO of Nautilus Minerals Corporation in Australia, in his presentation **Terrestrial Mines in the Sea; Industry, Research and Government**. In November 1997, Nautilus Minerals was granted exploration titles over the newly-discovered, high-grade, seabed, metal sulphide deposits at a depth of about 2000 m in the Manus Basin. The titles cover an area of over 5,000 km<sup>2</sup> within the archipelagic boundary which defines the territorial waters of Papua New Guinea. The deposits are actually a surface expression of more deep-seated hydrothermal activity related to diverging tectonic plates in the basin. Their proximity to the continental land masses has produced a suite of sulphide minerals of Cu, Zn, and Fe that carries with it anomalously high values of Au and Ag, unlike the mid-ocean sulphides in which the precious metals are generally sparse or absent. The minerals are found in individual chimneys, coalesced chimneys, or individual mounds forming on the sea floor at measurable rates and the economic evaluations that led to the granting of the exploration titles were based on surface sampling without regard to any minerals in the sub-seabeds.

While the latest in exploration technology is being employed, selection or design of equipment for mining must await the results of more detailed characterization of the deposits and their environment. There is no question that much of the technology advances that were presented here, and others that are being used by the deep sea oil and gas industry will be incorporated into the needs of hard-rock minerals recovery.

Another issue to which the speaker referred is the potential overlapping interests of marine mineral developers and scientific researchers. In this respect, the PNG Government announced in 1998 that a special policy regarding seabed resources is being developed. In the speaker's view, the relationship between the government and the commercial enterprise is the primary and most critical one in terms of confidentiality, and the work product of research organizations should be transparent to each of them. He discussed some other issues in detail including the importance of research, the identification and selection of appropriate data, guaranteed berths, rights of explorers, trespass, intellectual property, and the release of research information, all important issues with regard to the management of marine minerals development, whether within or without national jurisdiction.

*Dr. Zohair Nawab*, Geological Advisor, Kingdom of Saudi Arabia, spoke on the **Atlantis II Deep: a Future Deep Sea Mining Site**. The Atlantis II Deep lies in the axial trough of the Red Sea, approximately mid-way between the Kingdom of Saudi Arabian and the Sudanese coast almost due west of Jiddah. The bottom of the deep contains mineral-rich mud at a maximum depth of 2149 m. The site was discovered in 1965 during a research cruise of the RV Atlantis II of the Woods Hole

Oceanographic Institute. In 1975 the Saudi-Sudanese Joint Red Sea Commission was formed and continued actively through 1979 to carry out exploration and development on the deposit. Geophysical exploration and initial studies on technology for mining the muds were followed by a pre-pilot test perhaps best described as bulk sampling. The resources characterized amounted to about 90 million tonnes of mud containing 2.06% zinc, 0.45% copper, and 38.4 g/t silver, based on analyses of 605 cores, and two dimensional kriging of blocks 500m square. The metal content was assessed at 1.8 million tonnes zinc, 3,432 tonnes silver, and 404,000 tonnes copper.

Environmental studies were an integral part of the test programme and the method to recover the extremely fine-grained mud and hot brine included water jetting and hydraulic pumping to a converted drilling vessel for de-watering and transport to shore for treatment. Some 15,000 tonnes of hot, brine-saturated mud, further diluted with sea water, were pumped to the surface. The waste waters were discharged from the vessel at a minimum 1000 meters water depth. Four tons of concentrate were produced by flotation in sea water on board the vessel and several recovery options were tested at bench scale on shore.

The most promising method was pressure-oxygen leaching with recovery of marketable amounts of gold (Au), copper (Cu), silver (Ag), zinc (Zn), cobalt (Co), cadmium (Cd), and gypsum from solution.

The resources were considered adequate to support a commercial operation for about 20 years and in 1982, the current metal prices would have resulted in a DCF of up to 17%, depending on how the project was capitalized. Proposals for pilot testing at a one-tenth scale were submitted concurrently in 1982 by Preussag, BRGM, and the Research Institute of the King Fahd University of Petroleum and Minerals, Dhahran, but were not consummated.

### Scope for Cooperation

Discussions on **The Consortium Approach to Deep Seabed Mining** were led by *Dr. Michael Cruickshank* who presented a short paper on the subject. *Dr. Cruickshank's* paper focused on the industry structure in frontier areas such as soil and gas and how risk was being spread among a number of participants in the industry. The speaker recalled that in the mid-1960s development operations in the Clarion Clipperton Zone were begun by five international consortia representing 36 companies from seven countries. Over \$600 million was spent in research and development with the objective of producing metals from manganese nodules on a commercial basis. No one company would have had the risk capital to invest in such a venture, but together each one was able to do so.

Useful and valuable information is now available from some of the consortia that have withdrawn from the venture.

In relation to frontier oil and gas areas in the U.S., the speaker noted that companies work with the government to drill exploratory wells to obtain regional information that is shared by all participants, prior to the offering of designated blocks for sale by competitive bidding. More recently, oil companies have been forming cooperatives with service companies to explore and develop new, deep-water fields.

In the discussions, that followed *Dr. Cruickshank's* presentation, there appeared to be consensus that the consortium approach was a useful way to go. The presentations on nodule development indicated a considerable amount of repetition over the past thirty years and judging by the happenings in the oil industry it is indeed possible to work together, particularly in the early stages, and still be competitive. On the nodules it may be that most of the basic technical work has been already accomplished, but, in terms of environmental understanding, there are still many gaps in knowledge, particularly as most environmental issues are both place and time dependent and cannot be analyzed appropriately at any one point in time or location.

With regard to consortia among countries and other organizations with different legal and economic backgrounds and different levels of work already accomplished, some of the major problems may have nothing to do with technology. Intellectual and real property rights, legislative constraints, assessed or imputed values of work done, all may serve to complicate the issues which may end up being driven by social, political, legal, and economic factors. Nevertheless, there are situations where cooperative activities are highly cost effective and willing partners can make it work.

## Conclusions and Recommendations

### TECHNOLOGIES FOR DEEP SEABED EXPLORATION

The technology for manganese nodule exploration is appropriate and generally utilizes state-of-the-art equipment. In some cases the work carried out is building on earlier efforts but, in general, advances in technology or methodology have not been significant. Most exploration appears to be in support of environmental studies. The methods used are not standardized and there does not appear to be a lot of cross fertilization in this area, even though there should be little competitive concern among the pioneers.

*RECOMMENDATION:* Pool the existing information among registered pioneer investors where there is no competitive concern. Non-registered explorers may be invited to contribute non-confidential information, and research scientists invited to contribute wherever possible.

### TECHNOLOGIES FOR DEEP SEABED EXPLOITATION

A great deal of interesting and sophisticated engineering work has been applied by the individual pioneers in support of national R&D programs. Much of it appears to be duplicative and while a certain amount has been a necessary learning experience, there is a suggestion that we may have been reinventing the wheel. On the other hand, there was a near consensus that selected sites might be marginally economic at this time, and perhaps even profitable. A well-designed and managed operation might pay for itself and provide the experience needed to all participants.

*RECOMMENDATION:* The Authority should encourage the pioneer investors to share existing technology, rank the systems already developed, and incorporate advanced and proven systems from other industries where appropriate. Steps should be taken to form a "Pilot Enterprise", being a consortium of investors working together in a mutually agreed upon site under the approval and guidance of the Authority to develop a full-size pilot mining operation.



## ACCOMPLISHMENTS OF REGISTERED PIONEER INVESTORS

The Pioneer Investors have brought themselves up to speed in general with great effort and expense and have significant accomplishments in a number of focused areas. Much of this effort has been directed to understanding and characterizing individual areas.

*RECOMMENDATION:* The pioneers should consider cooperative efforts to get together and pool technology, analyse all work accomplished to date and identify bottlenecks. For future work they might consider setting up joint cooperative agreements where possible and appropriate to eliminate duplication of work

## ENVIRONMENTAL ISSUES

Importance of environmental issues has been generally accepted and major efforts have been made to characterize the pioneer areas. However, these efforts are lacking in standardization and commonly agreed models for testing impacts. There is a danger of duplication of effort, using the wrong model. This is particularly true if deposits other than manganese nodules are considered as well.

*RECOMMENDATION:* A small team should be selected under the auspices of the Authority, to analyze, in detail, the information and findings from the Sanya workshop and develop an appropriate model, or models, that can be used by all involved parties. Prior to publication, this document should be circulated for review and comment to appropriate persons and organizations on an international basis. The final publication should serve as a standard of excellence for use by the Authority and any other involved parties

## BOTTLENECKS IN RESEARCH

Successes have been amply discussed but failures and bottlenecks have not always been given the credit they deserve on the learning curve and mistakes are sometimes repeated. This applies to both technological and environmental research.

*RECOMMENDATION:* Again, a small team should be put together to study this issue. The most important effort is the inputs given to the leader to formulate a guidance document for future research activities. This particularly applies to standardization of data collection, data evaluation, and storage and retrieval of data and information. The document should be reviewed on an international basis by appropriate individuals selected from governments, industries, universities, and the lay public.

## THE CHALLENGES AHEAD

The restricted field of technology for the development of manganese nodules in the Area beyond national jurisdiction has been blown apart by the proliferation of advanced and adaptive technologies in other fields and for other resources, including but not limited to: metalliferous sulfides, cobalt crusts, deepwater oil and gas, hydrates, diamonds, sand and gravel, aerospace, medicine, computer science and biotechnology.

**RECOMMENDATION:** The Authority should continue its excellent work in broadening the scope of its authorized activities by additional workshops, internet communications, encouragement of joint research among universities, governments and industry, and the appointment of small teams to report and recommend action on special issues of immediate and future concern.

## SCOPE FOR COOPERATION

The value of cooperation and the development of consortia is an accepted way of sharing risk where the investments are too great for any one organization to commit. Past efforts that began the intensive research and development efforts for manganese nodules as a commercial venture were successful in their accomplishments, even though unsuccessful in their final goal. Despite the expenditures of over \$600 million, with no return, none of the 36 organizations involved was bankrupted by its actions. In the case where there is no true need for competition, then cooperative, or joint ventures are useful, cost saving and lead to positive actions. Some of the recent activities of pioneer investors appear to have been directed to non-sharing R&D efforts perhaps for nationalistic or inappropriate reasons which may have led to much duplication of effort and expense.

**RECOMMENDATION:** In keeping with Article 136 of the Convention that the Area and its resources are the common heritage of mankind, the Authority should continue and even accelerate its efforts to encourage pioneer investors and others to partner in resource development activities within the Area with the least possible imposition of costs to the operators that may be appropriate.

## THE USA SITUATION

Though only briefly discussed, it was obvious that the situation regarding claims of United States' industry within the CCZ, made under U.S. legislation and in cooperation with the UN Seabeds Committee was quite anomalous at this time as the U.S. had not yet signed the Treaty. Future actions planned by the U.S. or the

U.N. were not known or discussed.

*RECOMMENDATION:* None.

## **THE WORKSHOP**

The workshop was excellently attended and all participants contributed most strongly to its success, giving freely of their knowledge and understanding of the issues. The information presented was in many instances unique and without the experience and generosity of the speakers might never have been recorded.

*RECOMMENDATION:* The usefulness of the workshop was without doubt and it followed as an excellent complement to the recent Sanya workshop on environmental issues. The forum should be repeated in the near future to consider further progress in the development of minerals other than manganese nodules.



## Part I

# Technologies for Deep Seabed Exploration and Exploitation

<b>Introduction</b>	34
<b>Chapter 1 An Advanced Nodule Mining System</b> <i>Professor, Dr. Ing. W. Schwarz</i>	39
<b>Chapter 2 Nodule Collector Subsystems</b> <i>Professor, Dr. Ing. W. Schwarz</i>	55
<b>Chapter 3 Nodule Collector Subsystems</b> <i>Mr. Ted Brockett</i>	67
<b>Chapter 4 Fundamental Study for Development of a Collector Subsystem and its Future Technological Needs</b> <i>Mr. Katsuya Tsurusaki</i>	95
<b>Chapter 5 Undersea Platforms and Vehicles – The IKS Crawler</b> <i>Professor, Dr. Ing. W. Schwarz</i>	117
<b>Chapter 6 Deep Seabed Mining – Undersea Platforms</b> <i>Dr. James McFarlane</i>	133
<b>Chapter 7 Deep Seabed Mining – Lift Subsystems</b> <i>Professor, Dr. Ing. W. Schwarz</i>	153

## Introduction

The deep seabed polymetallic nodule deposits of commercial interest in the international seabed area “the Area” are to be found in the Clarion-Clipperton fracture zone in the northeastern equatorial Pacific Ocean, and in the central Indian Ocean basin. Polymetallic nodules occur on the floor of the ocean in a single layer. They contain various metals, among which nickel, copper, cobalt, manganese (and molybdenum, vanadium and titanium) are of economic interest. The grade of nodules (the content of the various metals of interest in a nodule expressed as a percentage of its dry weight) and the abundance of nodules (the weight of wet nodules per unit area of ocean floor usually expressed as kg per sq. m) determine the amount of metals contained *in situ* in a given area. Grades for potential economic deposits have been given in the general range 1.1-1.6% nickel, 0.9-1.2% copper, 0.2-0.3% cobalt and 25.0-30.0% manganese. The range for abundance is indicated as 5-15 kg per sq m. The grade of nodules in different areas of ocean floor, and also within a particular area, varies to a considerable degree. There are also variations in the abundance of nodules between and within areas of ocean floor.

An ocean floor that abounds with mountains, ridges, hills, scarps, troughs, basalt outcrops and boulders is one of the characteristics of the environment within which mining will take place. Large seamounts can range in height from 800 to 1500 m. Abyssal hills may be as high as 30 to 300 m, as long as 6 to 15 km and as wide as 2 to 5 km. Troughs can be 30 to 50 m deep, 250 m wide and 2km long. The slopes of some of these troughs may be in excess of 30 degrees. While polymetallic nodule deposits are known to occur in relatively shallow water depths, nodule deposits of commercial interest with requisite grade and abundance are found only on the deep ocean floor at depths between 3000 and 6000 m. Distances between the areas where mining may take place and the shore may be in the order of 500 to 3000 miles. That means that the market for products and the support base for the mining system will be hundreds of miles away.

In the effort to design a mining system to produce deep seabed polymetallic nodules from the international area, nodule mining technology developers have to address the basic questions: how to pick up the nodules from the ocean floor and bring them up to the surface facility at a profit.

Three basic design concepts for mining technology have been pursued. These are the hydraulic mining system, the continuous line bucket mining system and the modular or shuttle mining system. Of these three mining systems, the system that has drawn the most attention has been the hydraulic mining system. With regard to the capacity of the system, it has commonly been felt that for a nodule mining venture to be economic, an amount varying from about 1.4 to 9.0 million metric tons of wet nodules needs to be mined annually for a period of 20 to 30 years. Within this range, the most often quoted figure is 3.0 million metric tons of dry nodules, which is equivalent to about 4.5 million metric tons of wet nodules.

Against this background, experts were invited to prepare and present papers on past and current efforts to develop an integrated mining system and to report on progress that has been and continues to be made to improve upon the subsystems that are required for the operation of a cost-effective, integrated mining system. Part one contains the papers, presentations and summaries of the discussions that followed these presentations.

Professor, Dr. Ing. W. Schwarz of the Institute for Construction (IKS) of the University of Siegen, Germany, prepared and presented a paper on an integrated deep seabed polymetallic nodule mining system that is being developed at a pilot scale in a joint effort between German researchers and the Government of India. Unlike the large-scale operations that had been envisioned in the past, Professor Schwarz informed participants that the system being developed by the Institute and the Government of India is a very low capacity soft mining system. The mining system will consist of a number of small mining units and one mother ship. This will provide the flexibility that during repair work on any unit, the other units can carry on their mining activities, and in the case of storms, these units could be decoupled from the mother ship. The mother ship, in this instance, could then be piloted to a safe area. Professor Schwarz was of the opinion that with the introduction of improved and smaller scale systems, lower costs and break-even economics would result for the deep seabed nodules in the very near future. His premise included operations in the Indian Ocean, leased barges and other transportation facilities, and custom treatment of the ores. Chapter 1 contains Dr. Schwarz's paper, "An Advanced Nodule Mining System", his presentation and a summary of the discussions following his presentation.

Chapter 2 focuses on one of the sub-systems required for the operation of an integrated mining system, the nodule collector sub-system. The primary function of the collector is to gather nodules from depths greater than 5,000 meters, on low bearing capacity material and under high hydrostatic pressure. It is the most inaccessible sub-system. Three experts discuss different aspects of nodule collectors.

Professor Schwarz presented a report on the collector being designed for the system described in the previous chapter, Mr. Ted Brockett presented a paper on the extensive, comparative field tests of eight collectors carried out by one of the multinational consortia in 1978, and Mr. Katsuya Tsurusaki presented a paper on the theoretical design and testing of the interaction of collectors with the seabed.

Professor Schwarz affirmed the superiority of active collectors over passive collectors because of the reduction in the risk of clogging. He described how starting from the first OMI collector that resembled a potato-harvesting machine, a hybrid collector had been considered by his institute for further investigation, and how after further development, a mechanical, walking-beam comb device that was self cleaning had been designed.

Mr. Ted Brockett, Chief Executive Officer of Sound Ocean Systems in Seattle, detailed by video and slides, his experiences in 1978 of OMI's laboratory and deep seabed testing operations to compare some eight different collectors. Noting the purpose of the collector is to gather the nodules and deliver them bereft of sediment, to the intake of the vertical transport system, Mr. Brockett informed participants that of the designs tested, the simple rake and the hydraulic ramp and lift sub-system appeared to offer the most potential as simple commercial systems. He also remarked that with the advancement of technology over the past twenty years, it is easier today than ever before to accomplish the required tasks necessary to successfully mine the seafloor.

Mr. Katsuya Tsurusaki, General Manager of the Environmental Technology Department of Japan Environmental Management Association for Industry reviewed the development of nodule collector subsystems indicating that their performance and design is strongly affected by the geotechnical properties of the bottom sediments and of the nodules. He discussed these relationships with reference to the Japanese collector development and deep seabed mining tests conducted in 1997. Mr. Tsurusaki, while informing participants of their successful collector test at a water depth of 2,200 meters, asserted the need to improve the collector's pick-up efficiency. Future collector development should include a self-propelled mechanism with obstacle avoidance, extreme reliability of components and instruments, to obviate the need for retrieval of the collector, and a control buffer between the collector and the vertical lift.

Chapter 3 covers undersea platforms and vehicles. Two papers were prepared and presented on this subject. Professor Schwarz discussed seabed platforms specifically suitable for deep seabed mining and Dr. James McFarlane, President of International Submarine Engineering, prepared and presented a broad overview of the past, present and future of multi-use submarine platforms appropriate for any minerals development work.

Professor Schwarz outlined the basic requirements for ground impacting vehicles. He also described a crawler vehicle with toothed tracks designed for the Indian Ocean program but yet to be tested. Dr. McFarlane focused on the state of development of sub-sea platforms to deliver tools and sensors to the sea, or more specifically, on Remotely Operated Vehicles (ROVs), Autonomous Vehicles (ALTVs) and towed systems.

Chapter 4 contains the paper, presentation and a summary of the discussions on the lift subsystem that is being developed as part of the advanced nodule mining system by German researchers and the Government of India. Professor Schwarz, in this part, informed participants that after many tests and R&D on air-lift and hydraulic pumps, subsequent tests have suggested advantages in using a bottom-sited pump with a lock-chamber nodule feed on the discharge side of the pump. With this type of system, Professor Schwarz asserted that control of the bottom machinery would be more flexible and the ability to apply quick and recovery of the hose on surface would be enhanced.





## Chapter 1

# ADVANCED NODULE MINING SYSTEM

*Professor, Dr. Ing Wilhelm Schwarz  
Institute for Construction  
University of Siegen, Germany*

### **Retrospect**

**Targets of the Development for Advanced Nodule Mining Systems**

**Requirements for a Soft Mining System**

**Configuration of the Advanced Nodule Mining System**

**Nodule Collecting Devices**

**Future Operations and International Cooperation in  
Nodule Mining Systems**

**Summary**

## RETROSPECT

When the institute started the development of the mining technology for minerals from the ground in the oceans in 1981, a lot of work had been done earlier: Especially the famous OMI-Tests which had been carried out in 1978/79. I had started my developing work by studying the actual patent literature in those days, and I found more than 40 inventions.

The multitude of ideas for mining systems had been investigated, arranged into systematic lists and finally the ideas had been evaluated. Nowadays some of those inventions strike us as being odd. The most favoured system was that of OMI (Ocean Management Incorporated).

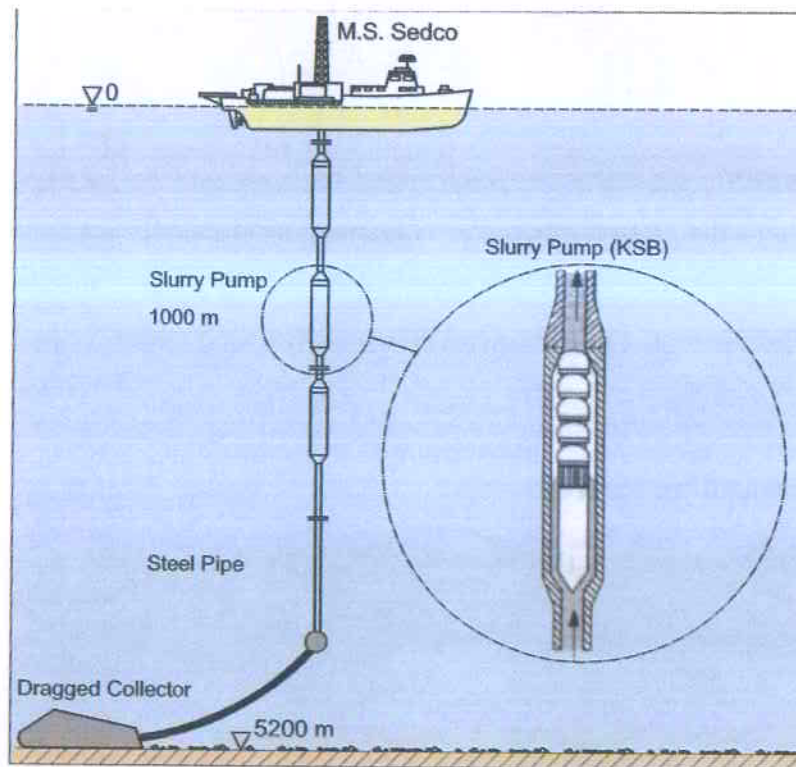

Figure 1 - OMI-System (KSB-Pump)

It consisted of a drilling ship (Sedco) equipped with moonpool drilling tower and rigid steel pipe for the hydraulic transport of the manganese nodules. The collecting device was dragged by the ship. Two collecting methods had been tested: one was a passive dredge type and the other was an active mechanical collector.

At the end of the 70s there was commercial interest in harvesting manganese nodules, because the world market price of metals like cobalt and nickel had been high, but afterwards the terrestrial mining processing efforts increased and the metal price decreased continuously, and, therefore, the commercial interests dwindled. Further, some developmental activities had been funded by the French and German governments. Within a bilateral project the GEMONOD-Group on the French side and a group of German institutes around the PREUSSAG-Company created the layout of an improved system.

The German group developed a brush-drum type and a rake belt type of mechanical collecting devices and later on a water-jet type of collecting device was also investigated. A very important mining system including a metallurgical processing plant. Both groups had reported in Houston at O.T.C.

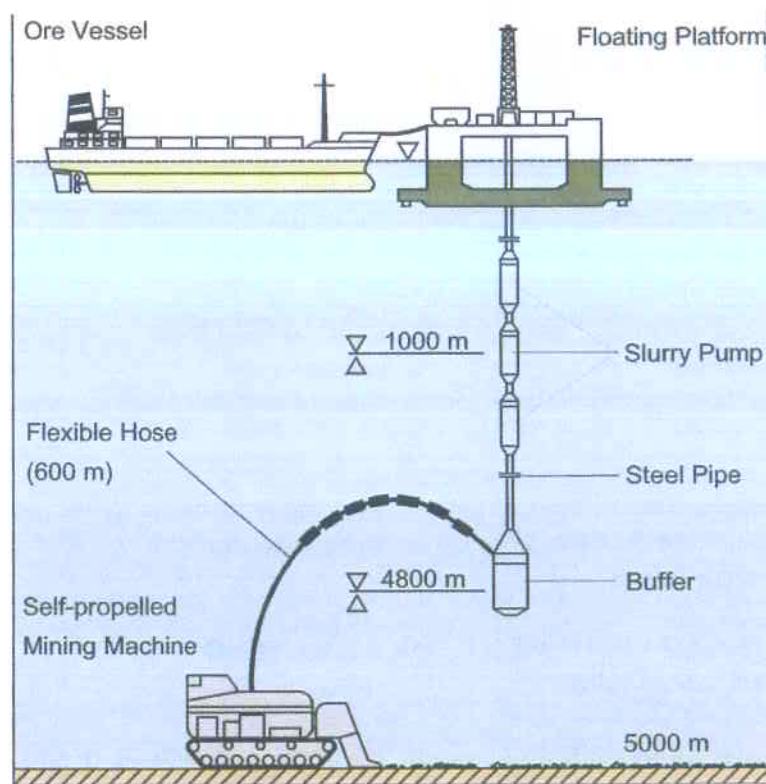

Figure 2 - Layout of a Commercial Manganese Mining System at the beginning of the 90s

The created system (figure 2) seemed to be fairly successful from the economical point of view, but there was no investor who was ready to spend the huge amount of money for a commercial nodule mining project. There existed some political, but mostly technical and economical reasons, to hold from the adventure

of deep sea mining, and therefore the French and German governments stopped their funding of the development programmes.

### **Keep out reasons for Potential Investors**

#### *Politics*

- The Law of the Sea (technological investments should have to be shared)
- Environmental impact and all uncertain consequences

#### *Economics*

- Decreasing of the relevant metal prices
- Low profitability at high financial risk
- Unknown availability and reliability of the system

#### *Technology*

- Giant and heavy mining equipment, too low mobility
- Energy consumption too high
- Heavy environmental impact
- Risk of losing all the equipment and human lives (caused by cyclones)
- The raw material supply of the metallurgical plant depends on only one mining system (3 Mio t/a)

In the end, I believe that nationalism and the traditional thinking of mining and metallurgic enterprise managers brought out the gigantic systems which had no chance for realization.

### **TARGETS OF THE DEVELOPMENT FOR ADVANCED NODULE MINING SYSTEMS**

- Cheap mobile mining system consisting of a fleet of small mining units (suitable investment and maintenance costs)
- Safe system for saving equipment and human lives: the big mother ship can escape from cyclones after decoupling from the mining units, each equipment with a floating station to fix the flexible hose and the cable

- Soft mining equipment: Smooth crawling on the ground, clean loading of the nodules and discharging of the clouded transport water in deep waters

These targets lead into flexible mining systems as can be seen in figure 3.

## REQUIREMENTS FOR SOFT MINING SYSTEMS

Soft mining methods are those which cause the smoothest influence on the environment. Earlier, some technologies for deep sea mining which interact with the deep sea ecology by violent impacts had been discussed. Those impacts must be avoided by responsible system designers. In detail that means the following:

Soft mining units are saving as much as it is possible by technical means

- Don't move the nodule collecting equipment by moving a ship.
- Use a flexible hose for the transport of the nodules and shape it suitably for saving traction power at the mining crawler.
- Go slow under water, because the flow resistances are growing by the square of moving speeds.

Soft mining units require smooth collecting devices

- Smooth collectors save energy and they touch the soil no more than necessary to separate the nodules.
- Smooth collectors produce only a minimal plume of sediments and they work slowly.
- Smooth collectors clean the nodules during the extraction operation from the ground.

Soft mining units discharge cloudy water at suitable depth

- Residual sediment and very small nodule fragments will be discharged under 1000 m depth, and the plume will not influence the spheres of biological activities.

Soft mining machines require a smooth track system

- Involute shaped teeth under big ground-pads.
- Automatic slip control of the crawler limits the moulding of the soil.

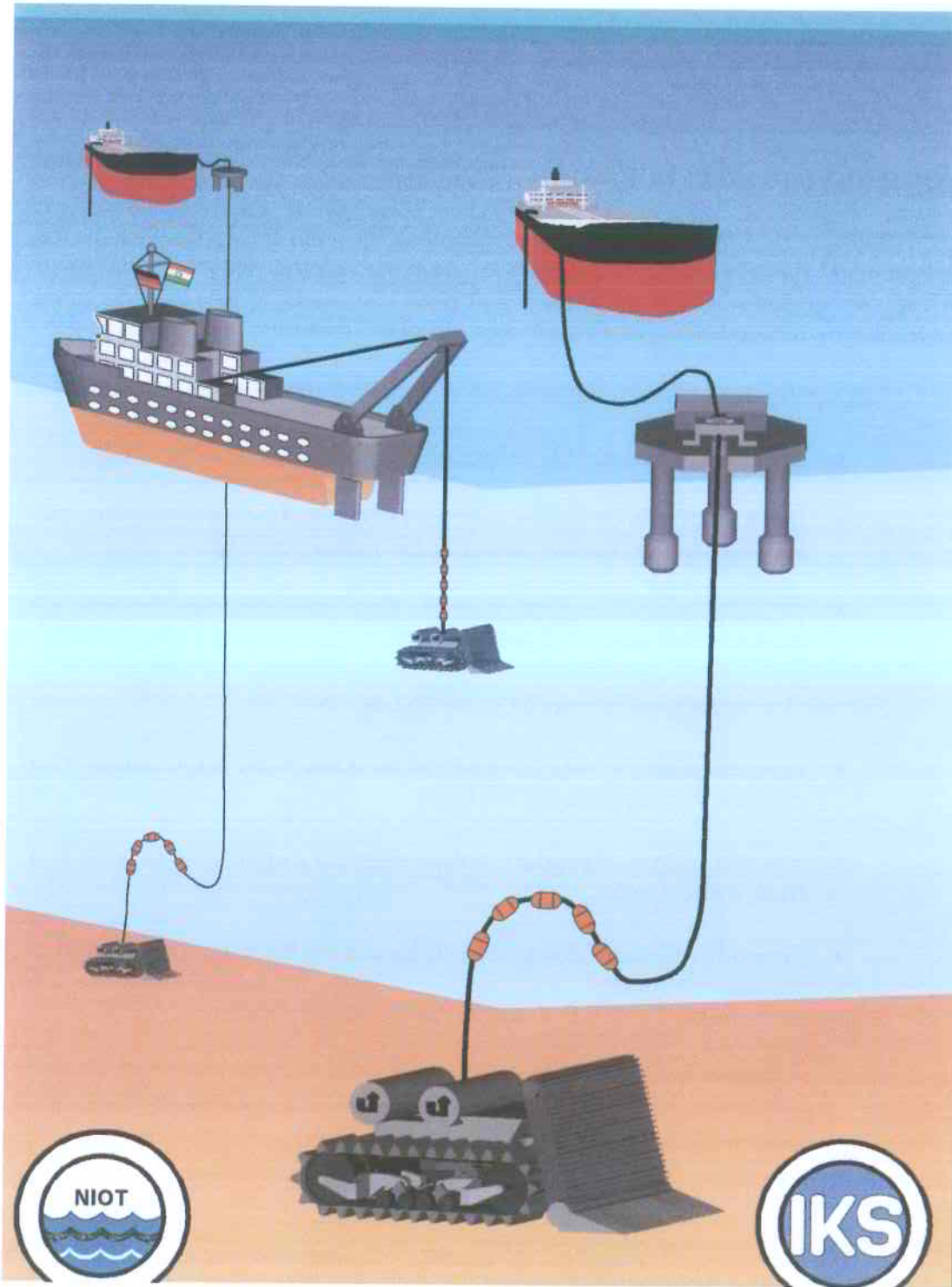

Figure 3 - Advanced Mining System

The IKS was involved in the German and bilateral development work. Since 1982 IKS started to follow its own ideas. These included:

- Nodule collector mounted on a self propelled crawler
- Flexible hose for the hydro transport of solids with high pressure inlet at the mining machine.
- Satellite mining system consisting of a number of small mining units and one mother ship. (During repair works on a unit, the other units continue their mining activities, and in case of a cyclone the mining units can be decoupled and the mother ship can escape).

## CONFIGURATION OF THE ADVANCED NODULE MINING SYSTEM

**What will an Advanced Mining System look like?**

In figure 4 the configuration of an advanced nodule mining system is to be seen. Mainly it consists of:

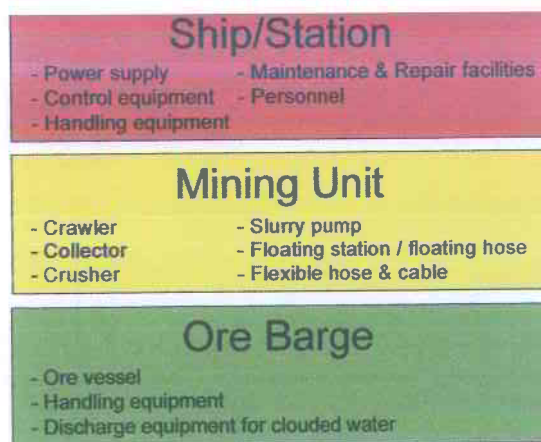

Figure 4 - Main components of an advanced Nodule Mining System

For an assumed pilot mining test in the Indian Ocean the sub-components are designed for 8-10 t w.n./h (25,000 t/a). An overview of the pilot system is shown in figure 5.



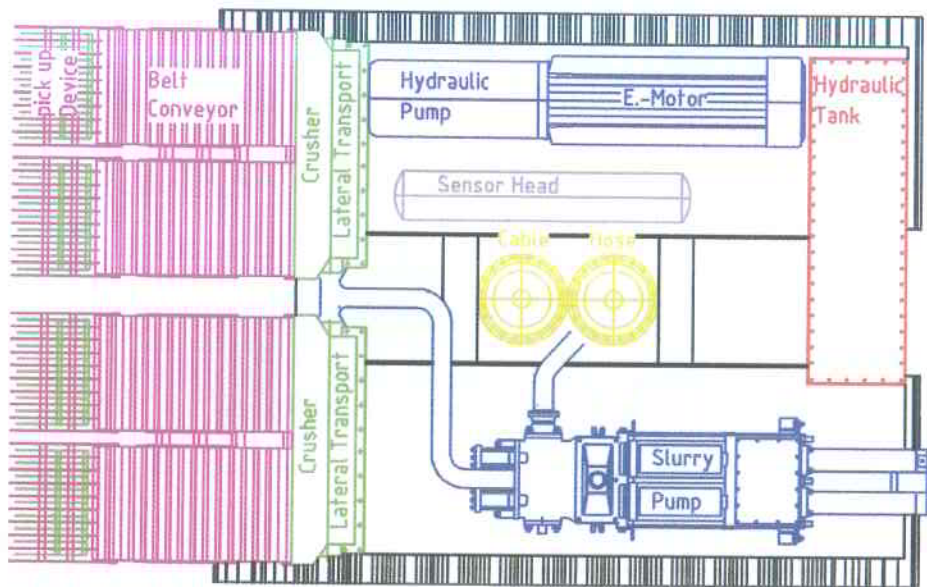
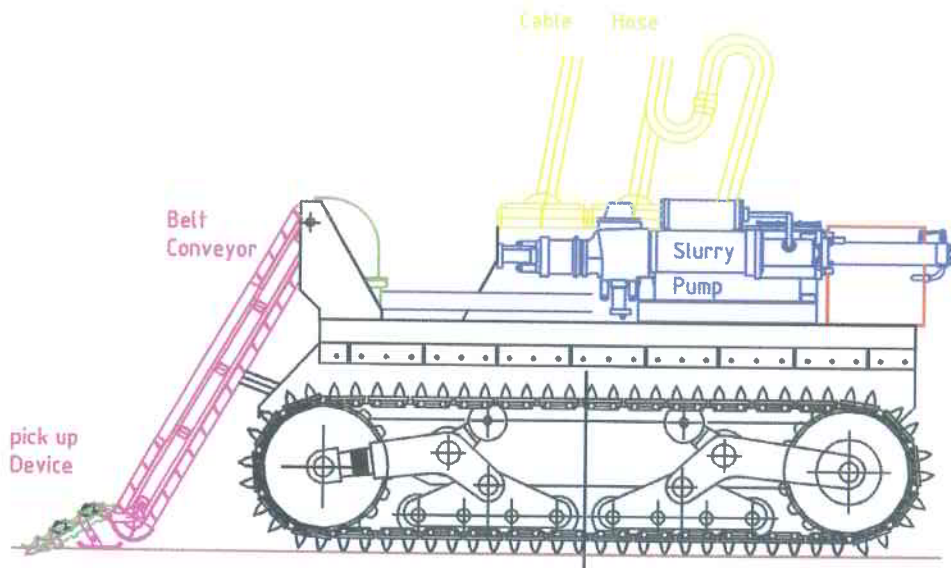

Figure 5 - Pilot Mining System

## Technical Data Sheet of the Pilot Transport-System

Mining capacity:	8-10 tonnes of wet nodules per hour
Total length:	5.5 m
Total width:	3.5 m
Total height:	2.4 m
Total weight:	8.5 t in water
Crawler speed:	0.15 m/s normal operation 0.5 m/s max speed
Width of the collecting device:	3 m
Max. grain Ø:	30 mm max after crushing
Inner hose Ø:	85 mm
Power consumption:	220 kW
Power supply:	6.6 kV, 3 phase.

The most critical components of the assumed nodule mining system are the following:

- Collecting device: pick up device, and steel belt conveyor
- Internal transport: lateral transport system, crusher, and density control of the slurry
- Lift Sub-system: slurry pump, and transport hose
- Crawler

Regarding further contributions of the IKS to the ISA-Workshop concerning "Undersea Platform/Vehicles" and "Lift Sub-system", the development of manganese nodule collectors are particularly interesting.

### NODULE COLLECTING DEVICES

Mechanical collectors are superior to the passive collectors such as Dredges because of the risk of clogging. The first mechanical collector, which was used by OMI, reminds one of a potato-harvesting machine. The principle of this collector is basically suitable. Such an experimental collector is shown in figure 6. This collector was tested, in a slightly modified form, on an artificial deep sea soil in the large testing channel of Karlsruhe.

### Technical Data of Test Collector

Mass flow of wet nodules	26 t of w.n./h
Effective collecting width	3 m
Envisaged dragging speed	0,5 m/s

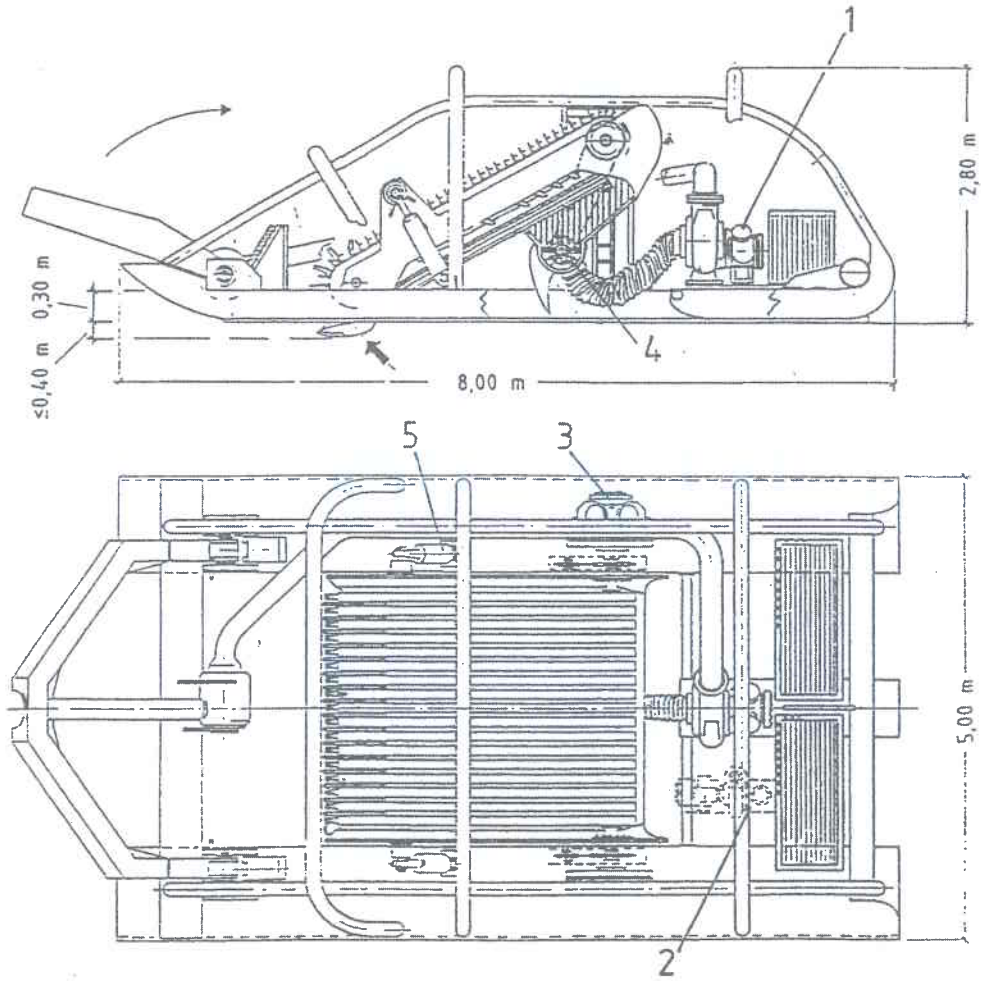

- |                                    |                               |
|------------------------------------|-------------------------------|
| 1 Slurry pump (internal transport) | 4 Lateral transport           |
| 2 Flush pump                       | 5 Adjustment of cutting depth |
| 3 Drive of belt conveyor           |                               |

Figure 6 - Mechanical Collecting Device (Test Collector 1985 Germany)

The test results corresponded only partly to expectations, and the following knowledge was acquired:

- The considered propulsion rate of 0.5 m/s could not be achieved.
- The rake tines were partly bent because of the blocking of the nodules
- The conveyor, made by linked steel chains, is inclined to strong oscillations.
- The tines of the rakes can clog with the soil.

Some of the shown disadvantages can be avoided by a belt-type conveyor with rakes, but the problem of clogging cannot be solved.

Big amounts of sediment are moved by this device and also disturbed to form clouds and by that are whirled up. Not only is the view around the mining machine fogged, but also the sea floor is heavily disturbed.

With respect to the unevenness of the sea floor and corresponding mechanical damages of the collector, the idea of a hydraulic pick-up method was considered. It was also felt that collecting speed should be increased. For this reason, a fluid-mechanical hybrid collector was developed and tested at the Berlin Research Institute of Hydraulic Engineering and Naval Architecture (VWS). The schematic diagram of this type of collector is shown in figure 7. At the Hannover fair "Industry '92" this collector was exhibited, figure 8.

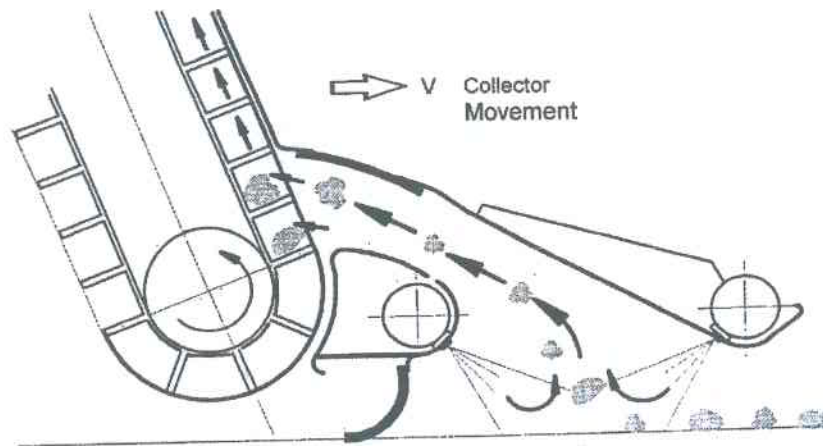

Figure 7 - Schematic Diagram of the Hybrid Collecting Device

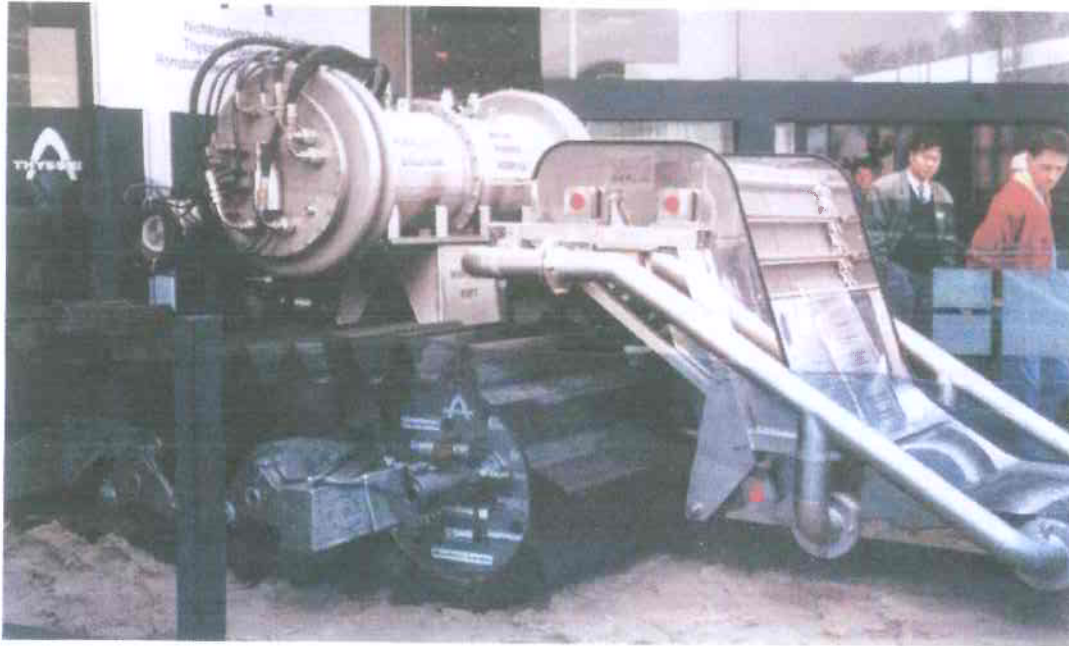

Figure 8 - IKS-Crawler & Hybrid Collecting Device

This collector still does not satisfy all requirements. In particular,

- The energy consumption is disproportionately high
- The maximum collecting velocity (forward feed) is only 0,35 m/s
- Very big amounts of sediment are whirled up

Because of the present experiences, IKS decided to develop a new mechanical collector. This collector is shown in figure 9 and it consists of a belt conveyor with flexible conveyor pumps and a mechanical pick-up device. Latter consists mainly of a comb-like grate-basis (basis comb), made out of profiled sheet metal, which is supported on the sea floor and by that maintains a constant effective collecting depth.

The front points of the basis comb undercut the sea floor, so that the manganese nodules are stacked up above. In connection with a second comb, which is mechanically moved in the gaps of the basis comb on a semicircle path a hauling gear is built.

This hauling gear works on the walking beam principle (comb loader). In order to be able to clean the nodules from the sediment while they are collected, a vibrator is installed at the basis comb. The two combs clean themselves of sediment by their relative movement.

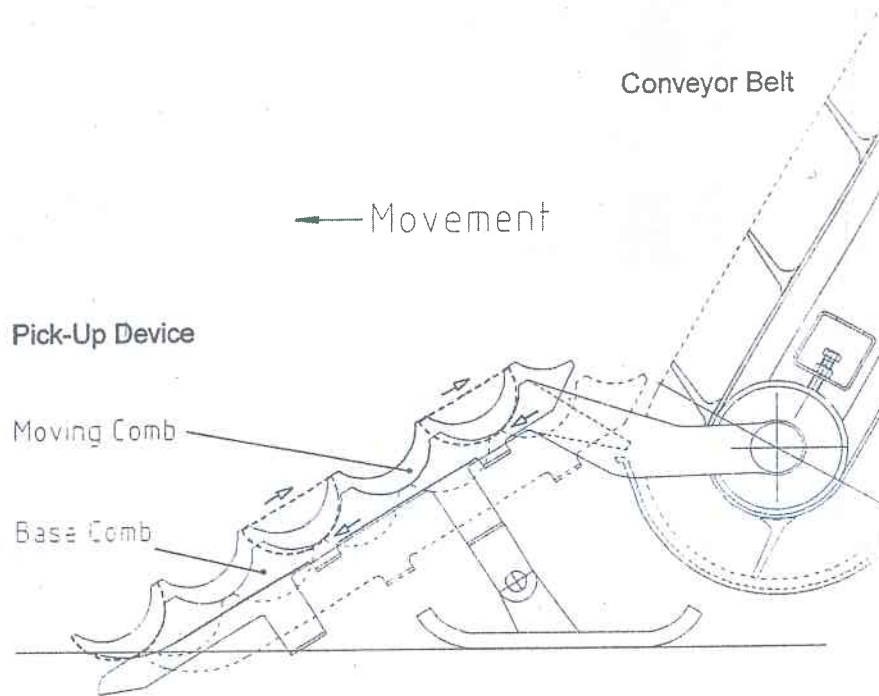

Figure 9 - Mechanical Collecting device

## FUTURE OPERATIONS AND INTERNATIONAL COOPERATION IN NODULE MINING SYSTEMS

It is very clear that the total mining capacity for deep seabed polymetallic nodules will be small at the beginning of commercial activities, and the world metal prices will not be influenced by the first deep sea mining activities.

Furthermore it is very clear that metallurgical process-plants will not be erected in Europe, but in South India near the Indian mining site or on the east coast of America, for instance middle America. Probably a metallurgical mill base will be situated in the east of Asia.

In view of constant low metal prices, nodule mining is not a high profit business, but it will be done, because there is a lot of free money for investing in industrial companies.

After successful testing the deep sea mining technology, potential investors will start manganese nodule mining enterprises; and mostly they will only sell nodules to metallurgical mills. These nodule miners will only operate as ore suppliers for the metallurgical plants. At least a world nodule market will be established. We can compare this market with the international iron-ore market.

In view of the very low transport costs for ore, it is clear that the future nodule mining companies will not pursue a fleet of ore barge, and therefore an international transport market will come up.

Taking into account that the investments for the installation of an advanced nodule mining system could be reduced to a low fraction and in front of the scenario of risk sharing by different industries the break even point of commercial nodule mining is very near.

## Summary of the Presentation and Discussions on an Advanced Nodule Mining System

In his presentation on an **advanced nodule mining system**, *Professor, Dr. Ing. W. Schwarz*, of the University of Siegen, discussed the history of commercial mining systems, particularly those of the French GEMONOD and the German Preussag collaboration with the consortium Ocean Management Incorporated (OMI). This group tested active collectors with submerged hydraulic pumps and, like most of the programmes of that time, based their economics on a minimum 3 million ton/year operation for the three metals, copper, nickel and cobalt. He suggested that traditional and nationalistic competitive thinking led to these proposals for gigantic operations that had little chance for success. In collaboration with the Government of India, the University recently developed plans for a more realistic advanced system that incorporated three new concepts: 1. A fleet of small, low cost, mobile, mining vessels to work as satellites around a "mother ship"; 2. mining equipment that could be easily de-coupled and re-coupled at the surface for protection and safety in the event of severe weather; and, 3. environmentally benign, or "soft" mining equipment that would not adversely impact the biological environment. Some of the components of the advanced system that the speaker described had already been tested successfully in shallow water near the Indian Ocean pioneer mine site

During the discussions on an advanced nodule mining system, participants focused on the economics of the proposed satellite system and the return on investment; the capacity of the proposed system, versus the investment and running costs of a fleet of mining units; and any advantages that this system may have over a single mining unit. Technical problems that could occur with so many units were discussed as well as other problems such as tailings disposal associated with the technology proposed.

### **Economics of the system**

In initial response, the speaker indicated that the 25,000 ton/year capacity system was a pilot effort to prove technical feasibility and that individual units, of which there might be four or five, would have a capacity of about 100,000 tonnes/yr, or almost half a million tonnes/yr from only one system. Two or three such systems could supply a large metallurgical plant. Economics at that scale would be similar to those calculated by the GEMONOD group in



France ten years ago where the break-even point was nearly reached even with the older technology.

The price of metals would influence the economics considerably and the current market value of a tonne of nodules was indicated to be between \$150 - 300, depending on the grade. Several participants supported the potential economics scenario and one gave the example of the change in factories and farms where large, central, steam-engine power was replaced with smaller and more flexible, multiple units driven by electric motors or internal-combustion engines. The ease with which venture capital could be raised was questioned and it was suggested that money would be available only on the merits of the venture in competition with other investment opportunities.

### **Technical innovation**

On the technical side, the use of a single-stage piston pump was questioned by a participant who had previously been involved in a similar operation that required several stages of pumping. He did, however, applaud the use of advanced petroleum technology involving flexible risers that are now state-of-the-art to at least 2,000 m. depth.

The speaker indicated that sufficient testing had been done to confirm the capabilities of a direct displacement piston pump to raise the required load in one stage. Regarding the potential for entanglement of the lines from multiple units, he said that this was not regarded as a problem in a well-ordered operation. Metallurgical treatment of the ore was briefly discussed and it was indicated that this was a well-researched area that would probably result in the application of pyrometallurgical extraction on land. The application of at-sea processing, however, was premature at this time. Some concern was expressed about the disposal of tailings, but the speaker pointed out that the soft mining method proposed would result in very little sediment to be disposed of at sea. The majority of tailings would be from the on-land processing and would be dealt with by well-tried methods.

## Chapter 2

### **NODULE COLLECTOR SUBSYSTEM**

*Professor, Dr. Ing Wilhelm Schwarz  
Institute for Construction  
University of Siegen, Germany*

**Development in Retrospect**

**Active Collector Devices**

**Advance Collector Design**

**Summary**

## DEVELOPMENT IN RETROSPECT

The available literature shows many ideas to solve the problem of collecting manganese nodules on the ocean bed which have been investigated in the past. But these ideas are not satisfactory, because some of their features are not acceptable and others contain some explicit disadvantages.

In what follows, we will limit our considerations to those types of collecting devices, which are moved by a self-propelled crawler on the seabed. Here we differentiate between 3 potential methods of extracting the nodules from the soil.

- magnetic methods,
- mechanical methods,
- fluidic methods.

The magnetic principle was given up at a very early stage of the development because of the huge weight of the necessary magnetic equipment. The magnetic permeability of manganese nodules is rather low. The two remaining methods (mechanical and fluidic devices) have now been tested.

Mechanical collectors can be divided into two families: active and passive devices. Passive mechanical collectors are very simple units, like dredges. Active mechanical collector devices are more sophisticated. They consist of a mechanical pick-up unit in connection with a nodule conveyor. Active collector devices need mechanical drives, and therefore they may tend to be complicated and heavy.

### ACTIVE COLLECTOR DEVICES

After a comprehensive comparison between active and passive collector devices, active collectors tend to be favoured, nowadays, because the risk of soil-clogging is much lower with these units, when compared to passive devices. The disadvantage of clogging of passive devices can be avoided by flushing, but this again means additional pumps, higher energy consumption and, last but not least, a major plume of sediment being whirled up.

The first active mechanical collector used by the Ocean Management Incorporated Consortium (OMI) was similar to a potato-harvesting machine. The working-principle of this collector is basically suitable. It was tested with elusive success and unfortunately was lost during recovery.

An attempted mechanical collector for *in situ*-tests in the late 80s is shown in figure 1. In a slightly modified form it was tested on artificial deep sea soil in the large testing channel of the Institut für Maschinen im Baubetrieb (IMB) of the University of Karlsruhe. The test results only partly met expectations, the results being listed below:

- The required collecting propulsion of 0.5 m/s could not be achieved. (At higher collection speeds separation was blocked, but the collecting efficiency was rather good at low speeds).
- The rake tines were bent because of nodule blocking on the scraper plate.
- The scraper type conveyor was designed on the basis of steel chains and they oscillated strongly.
- The rake tines were clogged with soil.

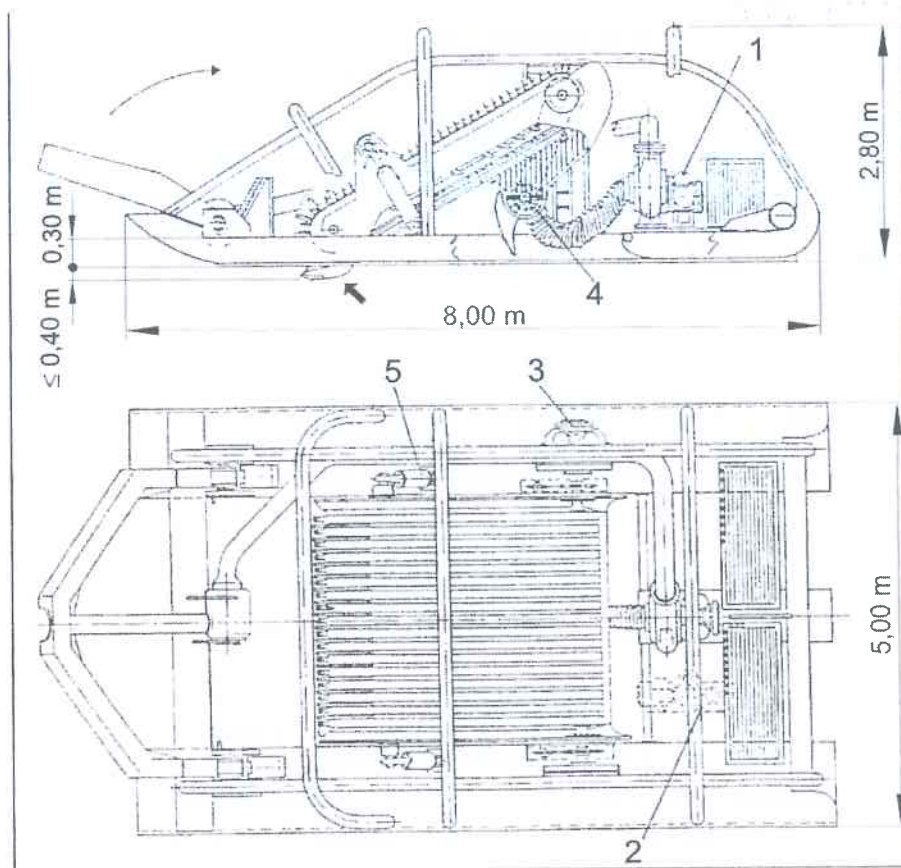

Figure 1 - Scraper type Mechanical Collector Unit (Test collector 1985, Germany)

Some of the named disadvantages can be avoided by a forward rotation belt-type conveyor with gripping tines, figure 2; but the clogging problem is not solved by this approach.

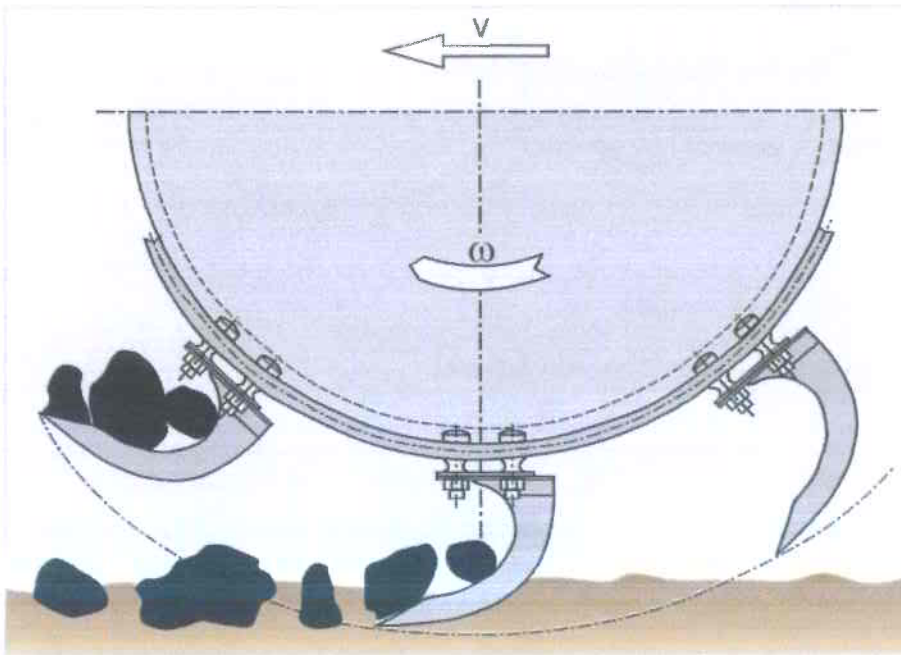

Figure 2 - Rake type collector with gripping tines

It is quite clear that huge amounts of sediment are moved by both rake designs. Sediments are whirled up and the plume disturbs the view around the mining machine. Further, the sea floor is heavily disturbed.

With respect to the unevenness of the sea floor and corresponding mechanical damages of the collector, a hydraulic pick-up method was considered with the following targets:

- avoid mechanical damages,
- increase the collecting speed,
- soft mining practice (no physical contact with the ground)

The fluid-mechanical hybrid collector was tested and developed at the former Research Institute of Hydraulic Engineering and Naval Architecture (VWS) in Berlin. The schematic diagram of this collector type is shown in figure 3.

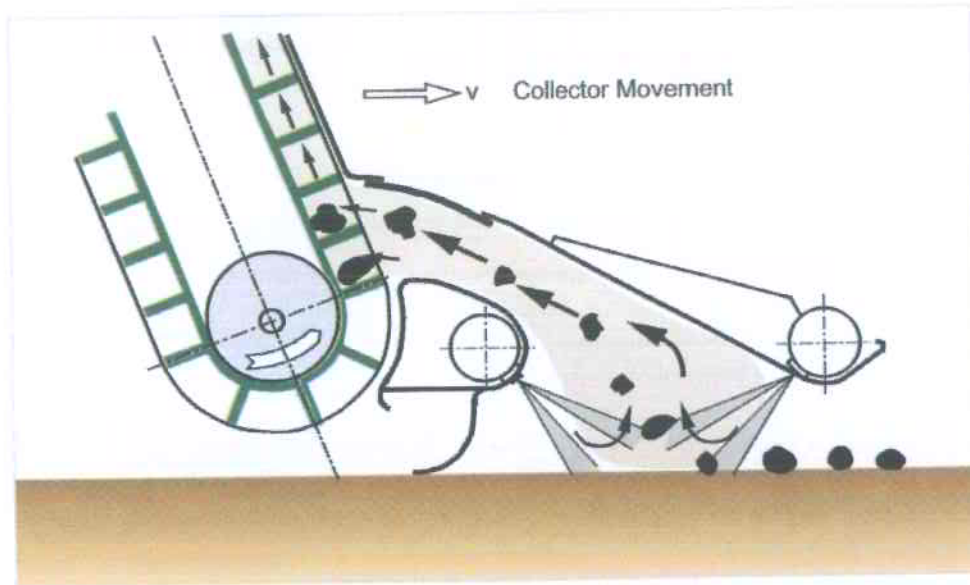

Figure 3 - Scheme of a Fluidic Mechanical Collector Unit (Test Collector 1985 German)

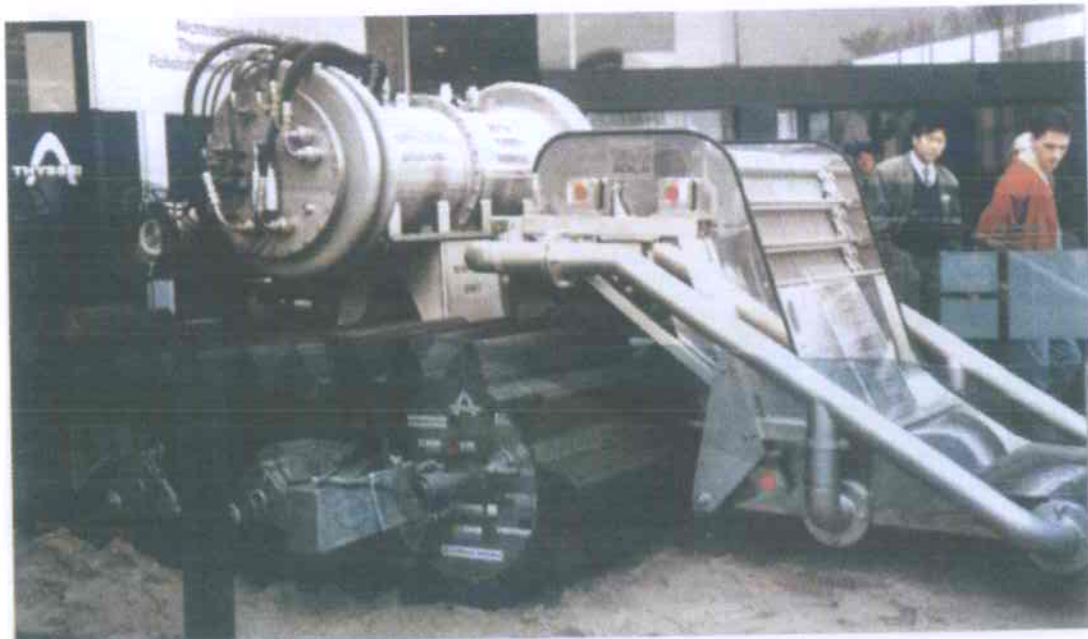

Figure 4 - IKS-Crawler and Hybrid Collector Unit

A practical model of this collector type was displayed at the Hannover fair "Industrie '92". It was mounted with the IKS-Deep Sea Crawler in the pavilion of Thyssen Stahl AG as all the stainless steel sheets of the IKS-crawler were sponsored by Thyssen Steel. The targets of development for the hydraulic devices have not been fully achieved for the following reasons:

- The energy consumption is extremely high,
- The optimal collecting speed is only 0.35 m/s, as the collecting efficiency decreases at higher speeds,
- Large amounts of sediment were whirled up so that the requirements of soft mining were not really met.

Yamazaki et al. from the Deep Ocean Minerals Association (DOMA, Japan) developed a collector unit which was later tested *in situ*. This collector is mounted on skids and pulled by a flexible hose. That pick-up principle is purely fluidic. The unit is shown in figure 5.

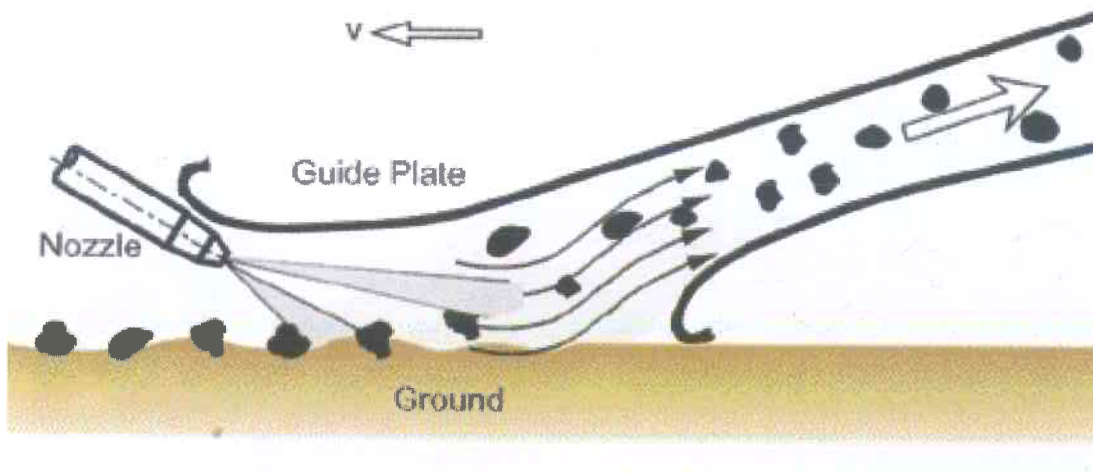

Figure 5 - Function principle of DOMA-collector (1995-97, Japan)

The suck-up rate of nodules with diameters ranging mainly below 30 mm was rather high (87%), but a major amount of deep sea sediments was sucked up, at the same time.

The towing speed of the collector unit fluctuated between 0.15 m/s and 0.41 m/s. Based on a collecting width of 4.6 m a collecting rate of 87% was achieved at a nodule density of 15.6 kg/m<sup>2</sup>.

For the breakthrough of nodule mining, two ways are recommended to increase the collector efficiency; increase the sweep area and decrease the downtime of the collector. To increase the sweep area a self-propelled mechanism an autonomous high performance equipment needs to be developed. To decrease the downtime of the collector, the total reliability of the whole system is most important. The amount of time for launching and retrieval of the bottom equipment must be shortened. Further safety devices to avoid risks from cyclones should be developed. Finally, Mr. Yamazaki (DOMA) recommends the installation of systems to observe and control collector and slurry lift sub-system performance.

## ADVANCED COLLECTOR DESIGN

A good deal of the development targets which have been determined by DOMA correspond to the targets of IKS. While the ideal configuration of a commercial collector sub-system may not be found, an optimal solution to mine nodules will be developed. For this, IKS compiles the requirements for a new concept.

### Requirements

- Maintain the defined working depth for 100 mm nodules over the total width of the machine.
- Comb the soil, don't peel it!
- Collect all nodules with size above 17 mm and below 100 mm.
- Avoid clogging of the collecting device
- Clean the nodules from soil residues while extracting them from the soil.



## Design Features

IKS is developing an active mechanical collector. The whole system consists of

- Pick-up device.
- Steep belt conveyor,
- Integrated crusher/lateral conveyor.

The concept of the advanced collecting device is shown in figure 6.

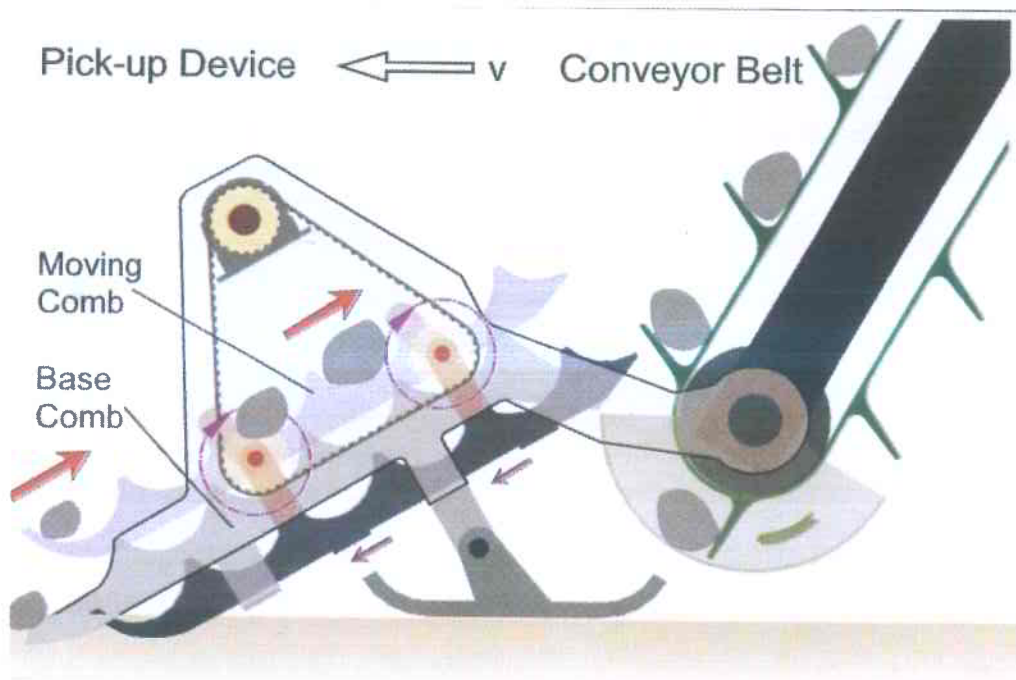

Figure 6 - Advanced Collector Module

The pick-up device has a joint at the lower conveyor drum shaft. With a slide pad it is supported on the ground. This basic component consists mainly of profiled sheet metal, assembled to a comb-like grate-basis (basis-comb). The front points of the basis comb undercut the sea floor, so that the manganese nodules are stacked up above.

A second comb is mechanically placed in the gaps of the basic comb. The system emerges as a walking beam conveyor. The moveable comb resembles a semi-circle. The drive of the system is a kinematic gear with a rotating motor.

In order to load already cleaned nodules from the sediment while they are collected, a vibrator is installed on the basic comb. The two combs clean themselves of sediment by their relative movement.

From the pick-up or loader device the nodules arrive at the inlet of the steep belt conveyor with elastic lumps.

At the upper end of the steep belt conveyor there is an integrated crusher/lateral conveyer device, (figure 7) and in the middle of the collecting subsystem the crushed nodules are sucked off.

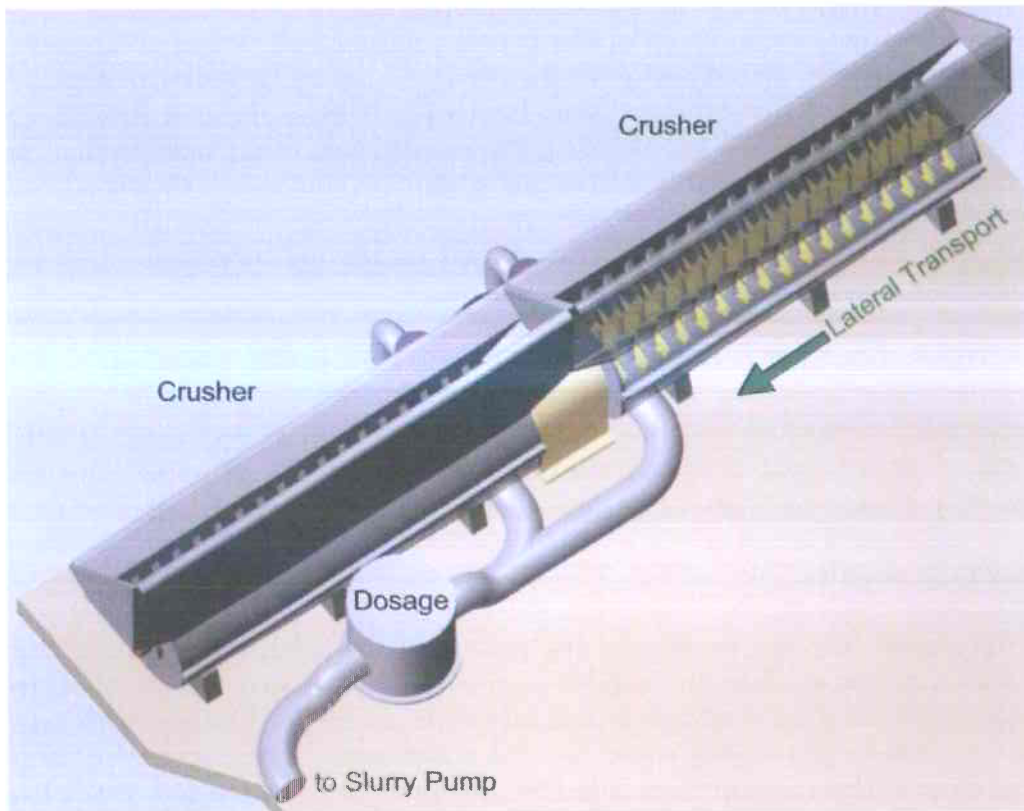

Figure 7 - Lateral Transport & Crusher Unit

## Summary of Presentation and Discussions on a Nodule Collector Subsystem (IKS)

*Professor Schwarz* affirmed that active collectors were superior to passive collectors because the risk of clogging was much reduced. He described the first OMI collector with which he had worked as resembling a potato harvesting machine. After testing, it was apparent that some form of washing of the nodules was essential. This led to the development of the hybrid collector with water jet assist for loading and washing. The hybrid machine disturbed too much sediment and further design led to the development of an improved, strictly mechanical, walking-beam comb device that was self cleaning. The speaker was of the opinion that the introduction of improved and smaller-scale systems would result in lower costs and break-even economics for the nodules in the very near future. His premise included operations in the Indian Ocean, leased barges and other transportation facilities, and custom treatment of the ores.

Three major questions were brought up for discussion focussing on the pickup including the sizing and cleaning of the nodules; the soft mining issues including the weight of the machine, the variation in ground characteristics and the need for avoidance capabilities; and the need for determination of mineability and trafficability prior to planning of the operations.

### **Cleaning the nodules**

Professor Schwarz reaffirmed his belief that the agitation of the walking beam was sufficient to clean the nodules even in the sticky sediments and that any free sediment picked up would be wiped off by the moving combs which are only 17mm apart. Water jet cleaning could be used, additionally, if necessary. Very large nodules over 100 mm would be avoided by raising the front of the pick-up device which is under constant observation and control by the operator. While agreeing with the technique, one participant pointed out that unless the collector was heading into the current, there was a strong likelihood of the visibility being reduced to zero.

### **The soft miner**

The use of the term "soft miner" was explained to mean a miner with the lowest ecological impact possible.

This would be achieved by disturbing the seabed as little as possible and by reducing the suspension of fine sediments by cleaning them from the nodules during pickup. The machine would also be supported on the soft sediment by ski-like pads for keeping the weight down and preventing excessive sinking. Another reason to use minimum weight in the design instead of adding buoyancy, which had been questioned, was to reduce the weight in air to ease handling and lower the cost on the surface. In response to a suggestion that the ski-pads could be modified to act as sensors for the depth of cut required, the speaker said that there were over 100 sensors in place on the machine already. In terms of soft mining, it was pointed out, however, that the removal of the nodules which provide a hard stratum for certain biota will result in an ecological impact that cannot be avoided if mining is to take place. The speaker agreed with that but also referred to the disturbance test reported by Professor Thiel (Thiel, 1997) where three years after complete disturbance of the bottom, life appeared to have returned to normal.

### **Ground characteristics**

The use of a tracked vehicle was questioned as it was well known that the bottom was, in many cases, formed of thixotropic muds that liquified when vibrated. The Ocean Minerals Company consortium had reported elsewhere (Welling) that the muds were so fluid that only a buoyant device would adequately support an active collector. The speaker agreed that the seabed was extremely varied in its geotechnical properties and in its topography but contended that their vehicle was designed for hard work, soft ground, uneven ground and obstacle avoidance. In fact the challenges of the vehicle design were even greater than for the collector. As one experienced participant pointed out, there are layers of muds, layers of crusts, layers with sub-sediment, areas of vertical or overhanging cliffs as much as 40 m high and areas with troughs as deep as 200 m.

There appeared to be consensus, however, that adequate pre-operational mapping of the ground characteristics including, particularly, the areas of soft muds, low nodule distribution and excessive bathymetric relief, combined with good steering and obstacle avoidance capabilities could compensate for the restricted capabilities of a track mounted collector. Good maps of mineability and trafficability, which are not yet generally available, would be needed to guide the collector in an appropriate, pre-arranged mining pattern



## Chapter 3

# NODULE COLLECTOR SUBSYSTEMS

*Mr. Ted Brockett  
President, Sound Ocean Systems Inc  
Redmond, Washington, DC, USA*

**Introduction**

**Collector Function**

**Collector Concepts**

**Concept Summary**

**Commercial Collector Designs**

**Conclusions and Recommendations**

**Summary**

## INTRODUCTION

During the 1970s I had what I believed to be the greatest job in the world. I was part of Ocean Management Inc's (OMI's) international team trying to determine the feasibility of mining the ocean floor for manganese nodules. This had never been accomplished before and the idea of being the "first" to do so combined with the technical challenges of working in the deep ocean and the romance of the sea made for an incredible adventure. Early in 1978 we conducted a Pilot Mining Test (PMT) program in the Eastern Equatorial Pacific and became the first in the world to successfully mine nodules from the deep Pacific. These tests were the culmination of more than six years of effort and millions of dollars of expense. At the time of the test, I was a Senior Project Engineer with INCO (The International Nickel Co., one of the OMI partners) and in that capacity I had overall responsibility for the collector development programme within INCO and OMI. It was my pleasure to lead a team of engineers from the United States, Germany, and Japan, working on the development and testing of the collectors and the collector subsystems.

My objective in presenting this paper and participating in the ISA 1999 Workshop on Proposed Technologies for Deep Seabed Mining of Polymetallic Nodules is to share with you some of the general knowledge and understanding that resulted as being a part of the OMI team. More than twenty years ago, the technical feasibility for deep ocean mining was proven. It was feasible then and it still is today. It was challenging then and it still is challenging today. But, with the advancement of technology over the past twenty years, particularly in the field of computer and fiber optic telemetry, it is easier today than ever before to accomplish the required tasks necessary to successfully mine the seafloor. It is my hope to give you sufficient information, based on extensive first-hand, practical experience, to allow you to conceptualize, develop, construct and test your own collector systems. It is my intent to guide you through this process while avoiding some of the costly and time-consuming pitfalls that slowed our progress back in 1978.

## COLLECTOR FUNCTION

Figure 1 is an illustration of a typical hydraulic lift ocean mining system. While a number of components are noted in the figure, the three primary components are the mining ship, the riser system, and the collector. As shown in the figure, the collector is generally attached to the riser by a flexible hose or boom and typically is the farthest and most inaccessible component of the system. Note that this idealized system schematic is deceptive because the vertical scale has been reduced so that all of the components can be seen. In reality, the collector is located more than 5,000 meters below the mining ship and would go unnoticed in a sketch of this size drawn to scale.

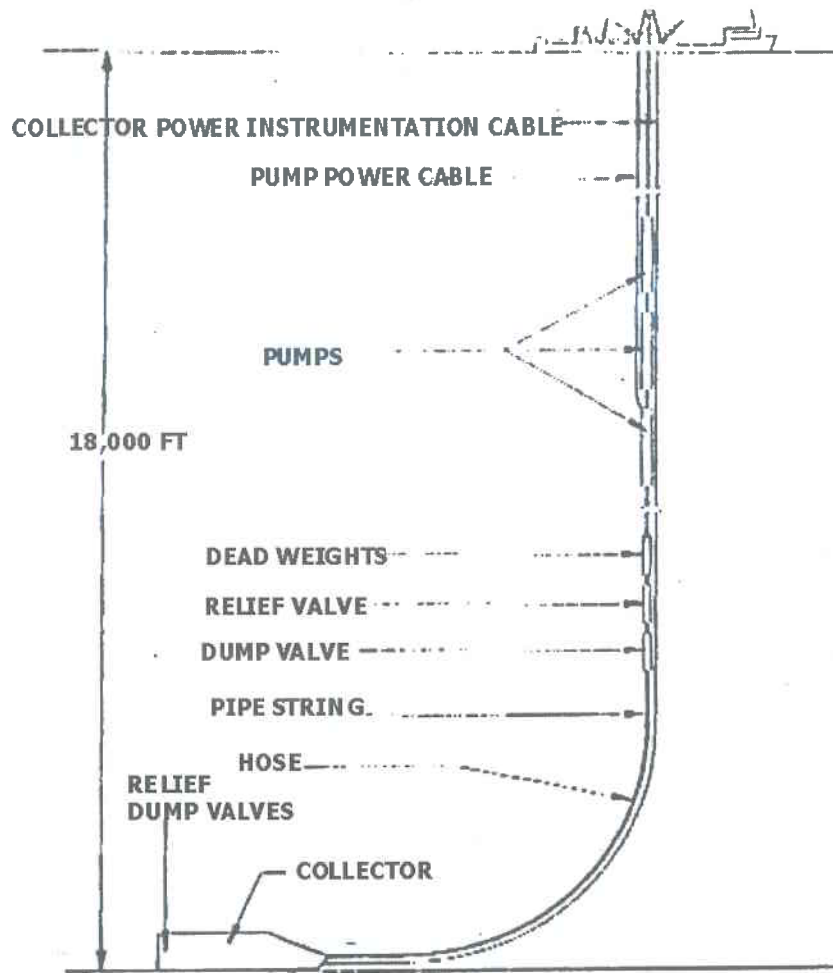

Figure 1- Hydraulic Lift Mining System



The primary function of the collector is to gather nodules, separate them from the seafloor and introduce them into the riser system for transport to the surface. Additionally, the collector is required to prevent oversized nodules and other materials from entering the ramp, and eliminate sediments and other unwanted fine materials before introducing the nodules into the riser.

### **General Characteristics**

It is important to remember that the collector is only one component in the mining system. While it is certainly an important and critical component, it is only one of many and as such it must be compatible with the rest of the components in the system. As a simple example, a collector with a nodule throughput capacity of 100 tons per hour will potentially clog and cause to fail a riser system capable of lifting only 80 tons per hour. Similarly, the collector must be matched to the forward speed and available power of the mining system, and must be compatible with the command and control system that interfaces with the collector.

The collector must also be matched to the environment in which it must operate. Its structure and all of its internal components must be able to withstand the high hydrostatic pressure that exists at depths greater than 5,000 meters. The seafloor sediment in the abyssal plains where nodules are found has relatively low bearing capacity to support collectors and it is very cohesive, with a tendency to stick to nodules and other objects like collectors that come into contact with it. The seafloor is often not flat and smooth like a parking lot but contains obstacles, slopes, and escarpments that must be successfully negotiated by the collector. Nodule distribution, which can vary widely within the confines of any mine site, plays an important role in the design and size of a collector.

Because the collector is so inaccessible, it must be reliable and capable of long-term, maintenance-free operation. Using present-day, oil drilling technology, it will require approximately three full days, operating twenty-four hours per day, to recover a collector to the support ship and then return it back to the seafloor. That does not take into consideration the time that might be required to repair or replace a damaged or failed component. With the high cost of lost production time and the continuing operating cost of the mining ship (in 1978, the SEDCO 445 cost more than \$40,000 per day), crew, and ore transport vessels etc, it is critical that a collector have a high mean time between failure and a similarly high mean time between required maintenance. The KISS principal (Keep It Simple Stupid), often jokingly referred to when designing marine systems, has particular significance when related to collectors.

A collector must be efficient at its primary function of collecting and separating nodules from the seafloor. Collection efficiency can be defined as the ratio of the actual number of nodules collected over a fixed distance on the seafloor divided by the total number of nodules encountered by the collector over that same distance. Collection efficiency has two primary components. The obvious one is inherent in the method by which the nodules are gathered. For example, some methods for lifting nodules off the seafloor might be very effective at removing large nodules but might leave small nodules behind. A collector utilizing such means would, potentially, be less efficient than a collector with the ability to remove both large and small nodules. The second efficiency component has, potentially, more impact and is the ratio of active collector width to total collector width. As an example, a towed collector that has a ten meter total width and two runners that are each one meter wide would have only 80% efficiency unless the design incorporated a means to gather the nodules in front of the runners that would otherwise be pushed into the seafloor by the runner.

Of somewhat equal importance is rejection efficiency. As previously mentioned, the collector must be matched with the riser system. Any riser system, be it based on submersible pumps or air lift, will have a fixed maximum capacity for lifting solids from the seafloor. The riser does not differentiate between types or solids such as sediment and nodules. Therefore, for every ton of sediment that is transported through the riser to the surface, one ton of nodules was not. Everything else being equal, a collector which can eliminate all, or substantially all, of the sediment that enters with the nodules will be better than one that can eliminate only a portion of the sediment. On a related note, sediment that is transported to the surface will be discharged back into the ocean with the potential for some environmental impact.

Redundancy is another key characteristic of the ideal collector. It is important that all critical collector components have redundant, or back-up, components. It is inevitable that components within the mining system will fail and it is therefore desirable to have redundancy wherever possible. Because it is impractical to have 100% redundant systems, the collector should be designed in such a way that failure of one non-redundant component does not significantly interfere with the primary function of collecting nodules. This idea strongly points towards the concept of modular collector design. The increased complexity associated with modularity is likely to be overshadowed by the increased flexibility and redundancy provided by modular designs.

Flexibility, another characteristic of collector design, is important because it can be used to maintain the operational reliability of the system. Due to the many

variations in the mining environment, particularly the sea floor sediments and nodule distribution, flexibility must be inherent in the collector design to accommodate the numerous changes that may occur during the mining operation.

Ruggedness is another crucial characteristic of a reliable collector system. The shipboard handling, seafloor landing, and actual mining phases of any mining operation will be physically demanding at best and potentially damaging at the norm. In order to operate reliably, the collector, its subsystems, and internal components, must be capable of withstanding the physical punishment that the operations and the environment will subject it to.

## **COLLECTOR CONCEPTS**

Collectors can generally be divided into two main classifications, active and passive. Passive collectors function without any external power supplied from the mining vessel other than the towing forces provided by the riser. Passive collectors therefore, will always be towed and not self-propelled. Note that collectors which self-generate power when towed across the seafloor are still considered as passive devices. Active collectors, on the other hand, require external power from the mining ship and can be either towed or self-propelled. Active designs can be further divided into three categories including mechanical, hydraulic, and hybrid designs which combine both mechanical and hydraulic components.

### **Passive Concepts**

Passive collectors generally have two primary components including a means for gathering the nodules and concentrating them in a window and a means for entraining the nodules into the riser. An example of a passive collector design is shown in Figure 2.

This rhomboid rake concept uses horizontally-oriented, fenestrated rakes to selectively concentrate nodules into a window which can then be entrained by the movement of water through a dredge head as it enters the riser. As the device is pulled across the seafloor, the initial set of rakes allows nodules of acceptable size to enter while forcing the oversized nodules out the side. The second set of rakes then concentrates the desirable nodules into a window while allowing the sediment and undersize materials to exit behind the machine. Water entering the dredge head is accelerated through the throat of the transition duct lifting and entraining the nodules into the riser for transport to the surface.

A variation of this same design incorporates a rotating, fenestrated drum to help eliminate sediment from the system. This concept is shown in Figure 3.

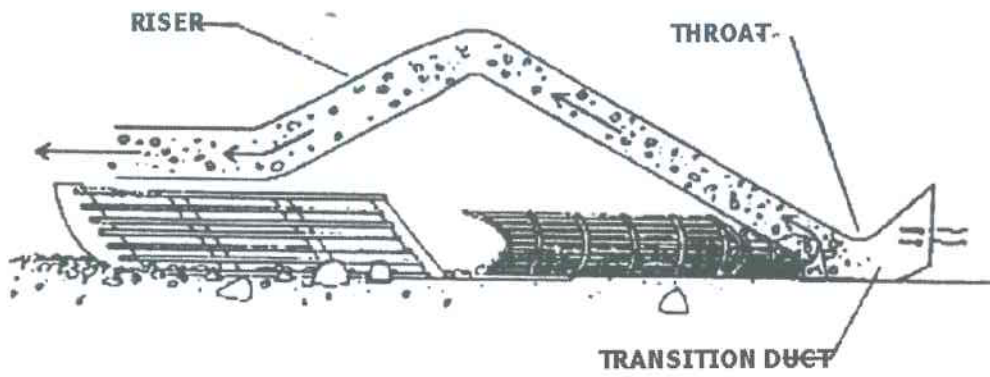
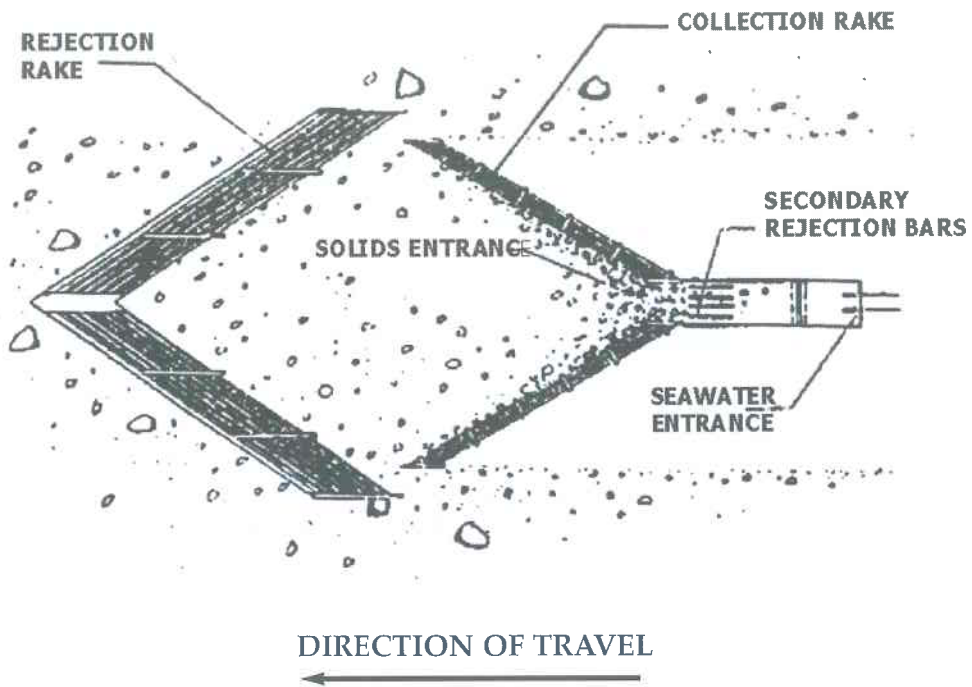

Figure 2 - Passive Rhomboid Rake

Rotation of the drum is caused by forward movement of the collector. External grouser blades arc used to generate the force required to rotate the drum. Internal blades are used to lift and drop the nodules as they pass through the drum. As the nodules fall, the movement of water through the drum will wash away some of the undesirable sediment.

Another example of a passive design is the passive, inverted plow concept shown in Figure 4. It is similar to the previous concepts in that it has a fenestrated gathering device and a transition duct used to entrain the nodules. It differs substantially in the sense that the relatively large base plate not only provides bearing support, but also plays a role in the collection process. As the collector is towed across the seafloor, the base plate pushes the nodules down into the seafloor positioning them in the upper layer of sediment. The plow, located at the back of the base plate, cuts this layer of nodules and separates it from the seafloor. The spacing between the base plate and the cutting edge of the plow determines the maximum size of nodules collected.

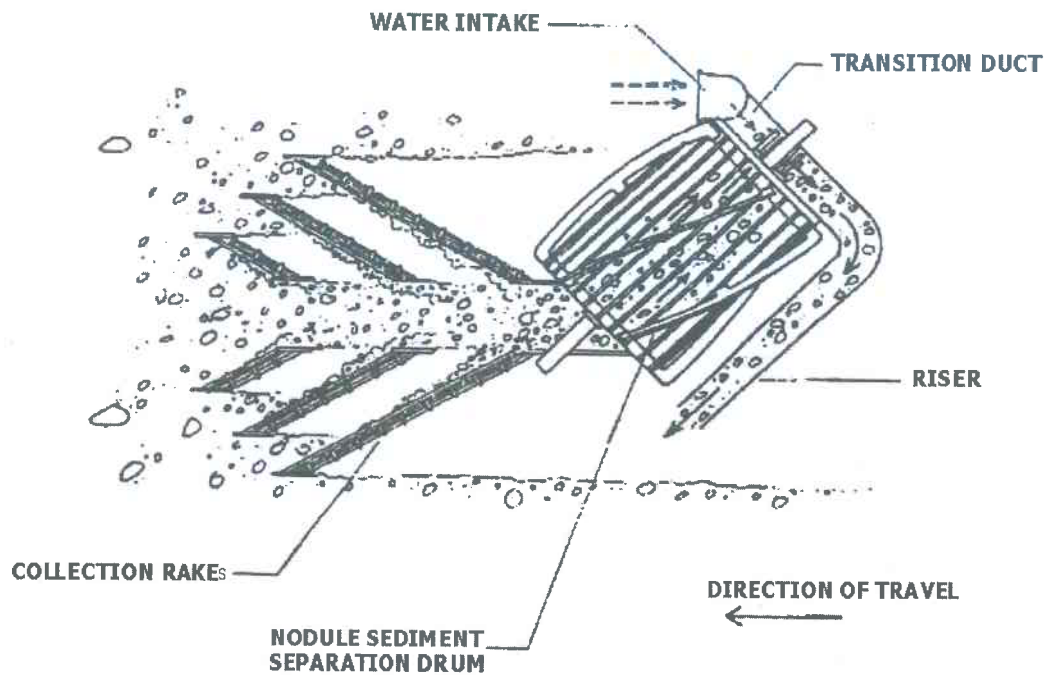

Figure 3 - Hybrid Passive Rake

Oversize rejection bars with spacing equivalent to the depth of cut are located in this same space. As the plow moves forward, the sediment is forced out through the fenestrations and the nodules are forced along the plow to the transition chamber.

While passive collector designs are attractive in their simplicity and reliability, experience has shown them (at least the ones tested to date) to be generally unacceptable and to have only limited applications for commercial mining operations. The single, biggest factor leading to this conclusion is the effect of sediment on the collection and rejection processes. As previously mentioned, seafloor sediment is cohesive and tends to stick to the nodules as well as to components of the collector.

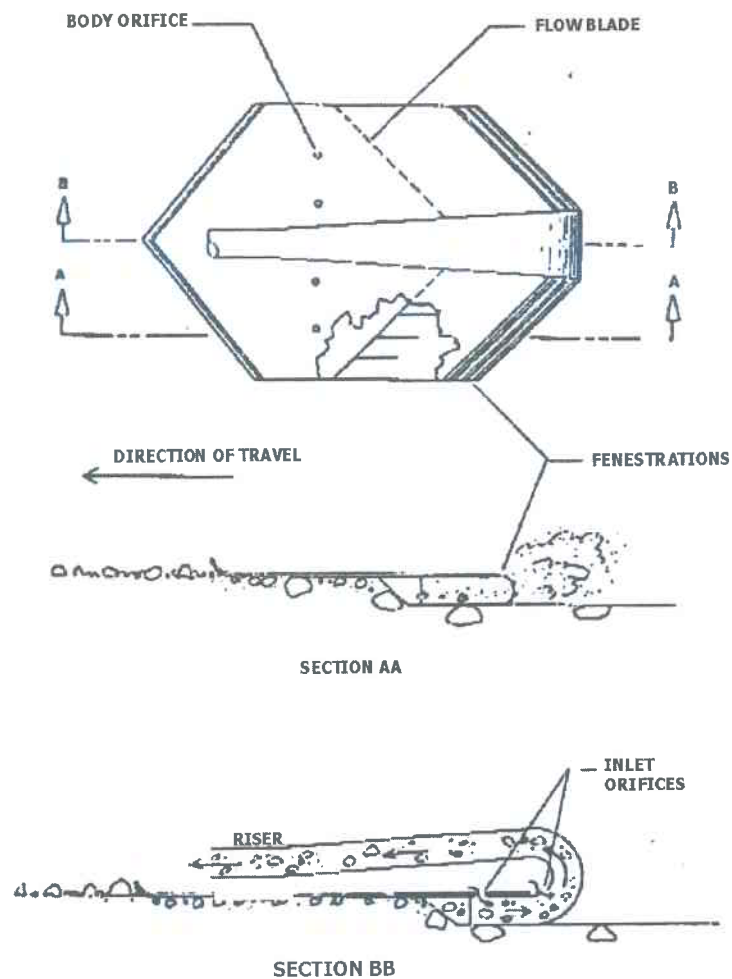

Figure 4 - Passive Inverted Plow

This tendency has two negative effects. First, without any active means for reducing sediment, relatively large quantities of sediment will enter the riser reducing the overall efficiency of the mining system. Second, the passive methods of reducing sediment simply don't seem to work. For example, the sediment that was expected to pass between the teeth of the rake, instead, moved along the rake with the nodules. We found that passive designs tended to generate large "bow waves" of sediment that moved along with the collector. This by itself caused two major problems. First, the forces required to move the collector across the seafloor became substantially larger because of the relatively large mass of sediment that moved with the collector. Second, the bow wave tended to push the nodules into the sediment or off the side of the collector making the device terribly inefficient.

### **Active Mechanical and Hybrid Concepts**

Active mechanical designs use moving machine elements such as rotating bucket wheels and chain conveyors to accomplish the basic collection and transportation functions. It is the author's opinion that truly mechanical collector designs are impractical and will not be used in commercial practice without the addition of nozzles and other hydraulic concept components. Here, too, the driving force behind this opinion is the effect of sediment. Mechanical designs, by nature, will tend to pick up sediment as the two example concepts discussed in this section will show. In both examples, the collectors separate the nodule bearing upper layer of sediment from the seafloor. The nodule sediment mixture is then transported within the device for introduction into the riser. In the hybrid designs shown, the sediment is removed by passing the mixture through a series of nozzles which are designed to wash the sediment off of the nodules and out of the collector.

Figure 5 illustrates the mechanical drum concept which uses scoops attached to a rotating drum to remove nodules from the seafloor. As mentioned, this design removes the entire upper layer of seafloor including the sediment and nodules. While in the scoops, the mixture is washed by high velocity nozzles to eliminate the sediment. The cleaned nodules are then dumped into a transversely oriented conveyor which transports them to a central hopper for introduction into the riser system. Oversized nodules picked up by the scoops are rejected at two locations. Rejection bars with the appropriate spacing can be installed at the point where the nodules fall from the scoops into the drum core. The large nodules prevented from entering the drum would then remain within the scoops and would be discharged during the downward half of the rotation cycle. Oversize rejection bars could also be located at the entrance of the hopper.

Nodules too large to enter could be crushed and then allowed to enter, or they could simply be discharged back to the seafloor. The rejection bars could be

used at both locations with different spacing. For example, widely spaced bars at the drum could be used to reject excessively large nodules while allowing certain oversized nodules to pass. The bars positioned at the hopper would then be used to screen the remaining oversized nodules. Note that in one version of this rotating drum concept, the scoops are replaced with curved tines or bars. As the bars pass through the seafloor lifting the nodules, less sediment is lifted making the concept more efficient.

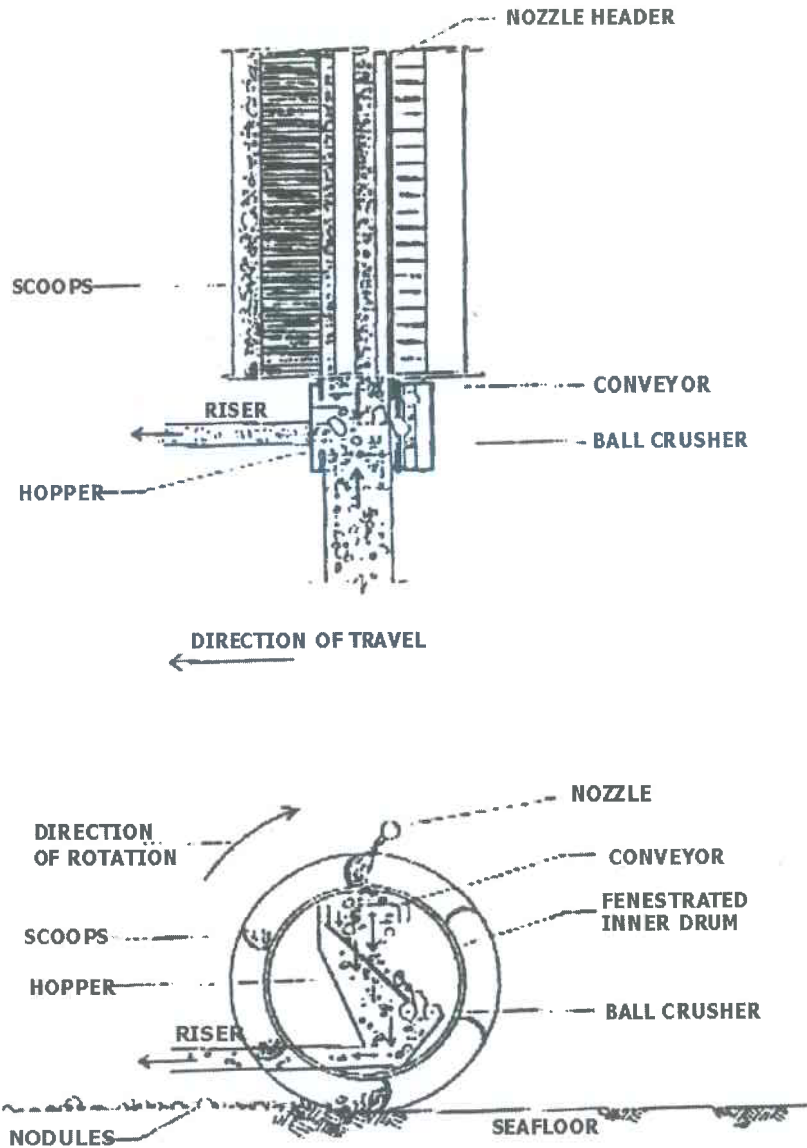

Figure 5 - Mechanical Drum Concept



The mechanical ramp concept shown in Figure 6 uses the mechanical cutting action of the lower edge of an inclined ramp to separate the upper layer of sediment and nodules from the seafloor. Scraper bars, or rakes driven by continuous belts or chains remove the mixture from the cutting surface and transport it up the fenestrated ramp. As the nodules are moved up the ramp, both the nodules and conveyors are washed free of sediment by high velocity water jets. A secondary conveyor located just aft and below the upper end of the main ramp is used to transport the nodules to a centrally located riser entrance. Oversize nodules are separated by a series of sloping rejection bars located along the top of the entrance hopper as shown.

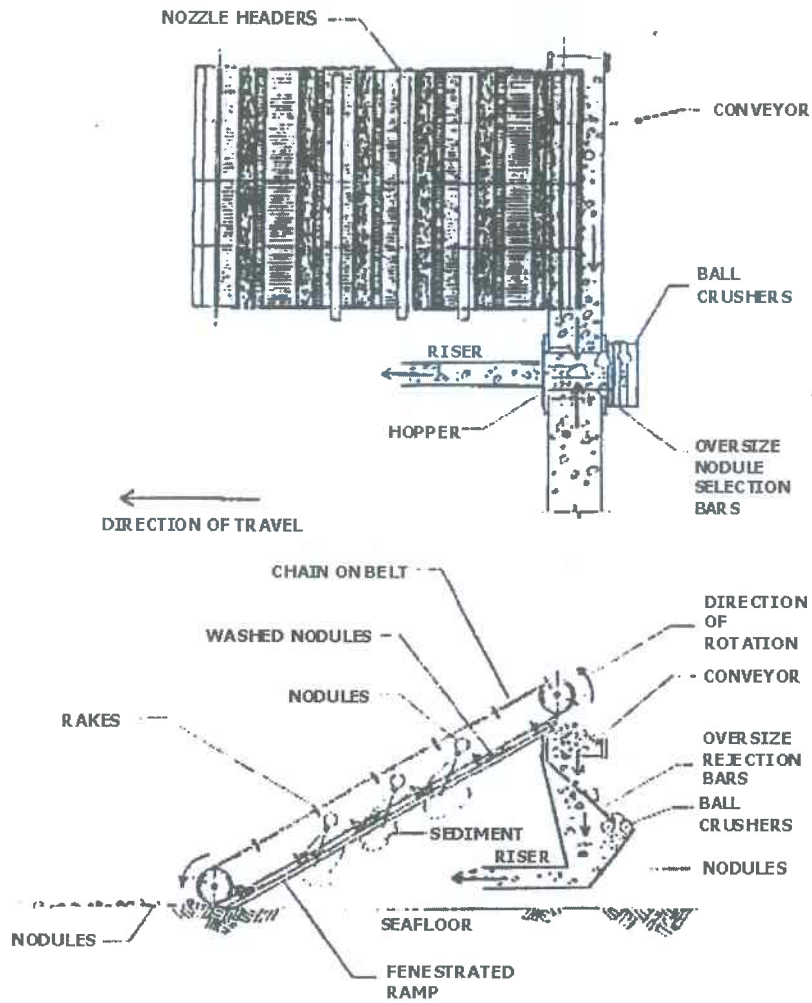

Figure 6 - Mechanical Ramp Concept

## Active Hydraulic Concepts

As mechanical collectors use machine elements to separate and move nodules, hydraulic collectors use moving seawater to perform the same functions. In the simplest systems, this hydraulic power is generated on the collector by an open cycle pumping system. The use of seawater as the recovery and transport medium eliminates the contact of moving machine elements with the seafloor and aids with the cleaning of sediment from the nodules before they enter the riser. The three hydraulic concepts discussed here differ only in the way they interface with the seafloor for the collection of nodules.

The hydraulic ramp collector, Figure 7, is somewhat similar to the mechanical ramp concept in that the lower edge of an inclined ramp is used to dislodge the nodules from the seafloor. However, the cutting edge of the ramp scrapes only the sediment surface and does not cut and remove a layer of seafloor sediment. As the

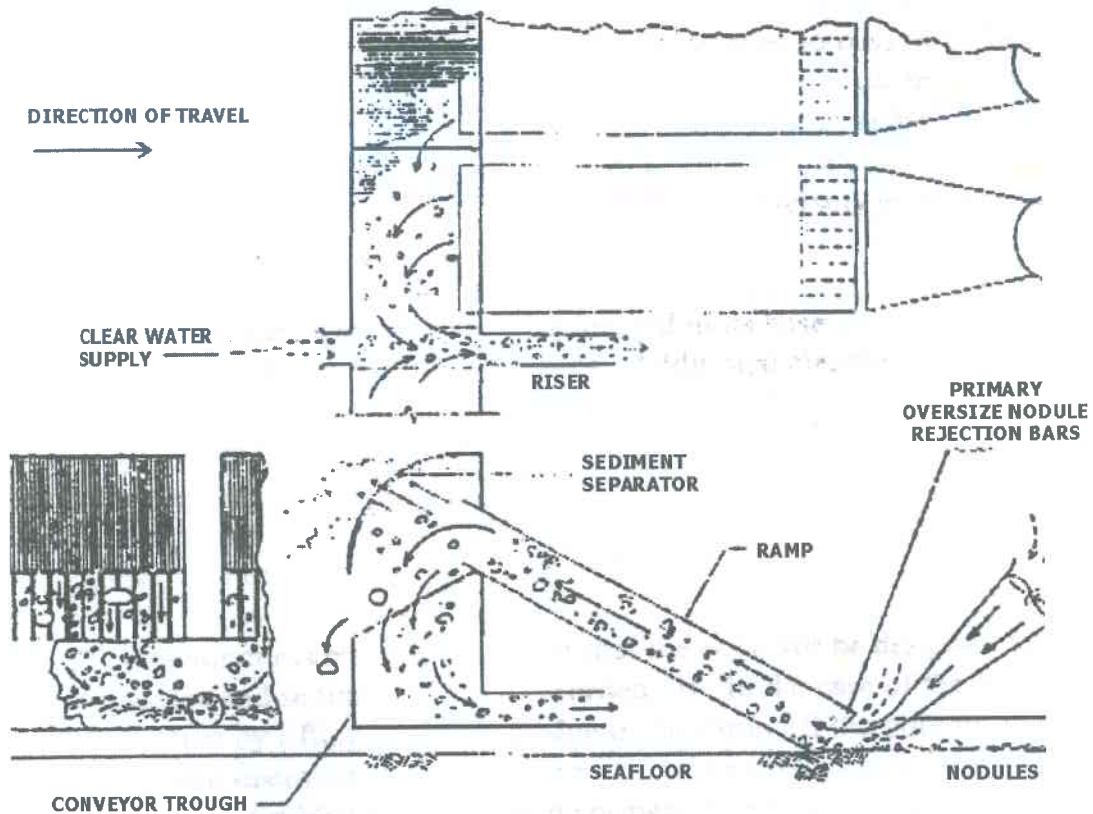

Figure 7 - Hydraulic Ramp Concept

nodules are pushed up into the ramp entrance, they are removed by high velocity water jets. These jets, directed at the ramp entrance by the primary nozzle, entrain large volumes of surrounding water and provide the means to transport the nodules up the ramp.

The ramp, which is actually an enclosed duct, confines the nodules and transports them to a height sufficient for sediment separation and lateral transport across the collector. Because of the turbulence of the water jets and flow in the duct, the nodules are generally cleaned of sediment before they reach the top of the duct. The discharge of the duct is directed at a sediment separating screen which deflects the nodules down into a conveyor trough. At the same time, the orientation and bar spacing of the screen allows the water stream containing the sediment to pass through and discharge out the back of the collector.

Oversize nodule rejection is accomplished in two locations. The ramp is protected from clogging by the primary oversize rejection bars at the entrance. As the nodules are diverted from the ramp they drop onto a secondary set of rejection bars. The spacing of these bars allow only nodules of a size acceptable to the riser to pass into the conveyor trough. Nodules too large to enter slide down the bars back onto the seafloor. With proper spacing of the primary rejection bars, the secondary bars can be eliminated and the sediment separating screen can be extended down to enclose the conveyor trough. Note that if the spacing of the primary bars is too close, it can adversely affect the collection process.

The conveyor trough uses a series of nozzles located in its base to transport the nodules across the collector to the riser system entrance. Additional cleaning of the nodules takes place as they are moved across the width of the collector. To minimize the amount of sediment entrance by the riser, the nodules are dropped from the hydraulic conveyor to the riser entrance trough. A nozzle located at the back of the trough is used to supply clean water to the riser. The sediment contained in the conveyor transport water can be allowed to discharge out the back of the collector.

As with all collector concepts, it is important that the collector be designed to allow free passage of nodules and sediment when it is turned off. In the case of the hydraulic ramp concept, this occurs by lifting the leading edge of the ramp off the bottom when the collector is in a non operational mode. This process is easily accomplished with the use of large diameter rubber bladders and return springs. The bladders can be automatically inflated when the collector is operational pushing the ramp down to adjustable stops that have been preset at the desired height. When the collector is turned off, the bladders will deflate under the force of the springs and the ramp will raise to a safe height above the seafloor.

The hydraulic plow collector shown in Figure 8 is, in actuality, a hybrid design which uses both hydraulic and mechanical means to separate the nodules from the seafloor. Similar to the passive plow, discussed previously, the base plate of the collector provides the bearing support and aligns the tops of the nodules with the bottom surface of the collector. As the collector moves across the seafloor, the solids entrance, located below the base plate, separates the layer of nodules and sediments. Water jets, directed at the entrance ramp, remove the nodules and sediment from the solids entrance area and transports the mixture up the ducted ramp. Similar to the hydraulic ramp concept, the nodules are washed of sediment as they move up the inclined duct. The hydraulic plow concept would have sediment rejection means and nodule transport conveys similar to the previous concept. Note that

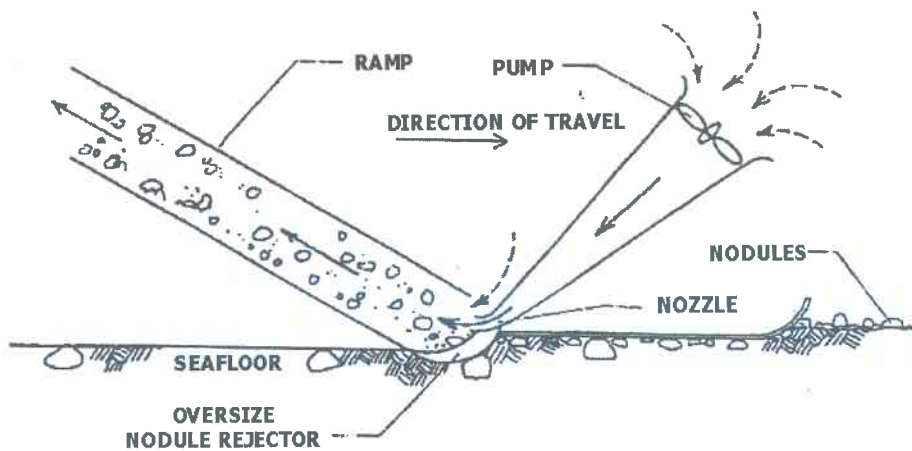

Figure 8 - Hydraulic Plow Concept

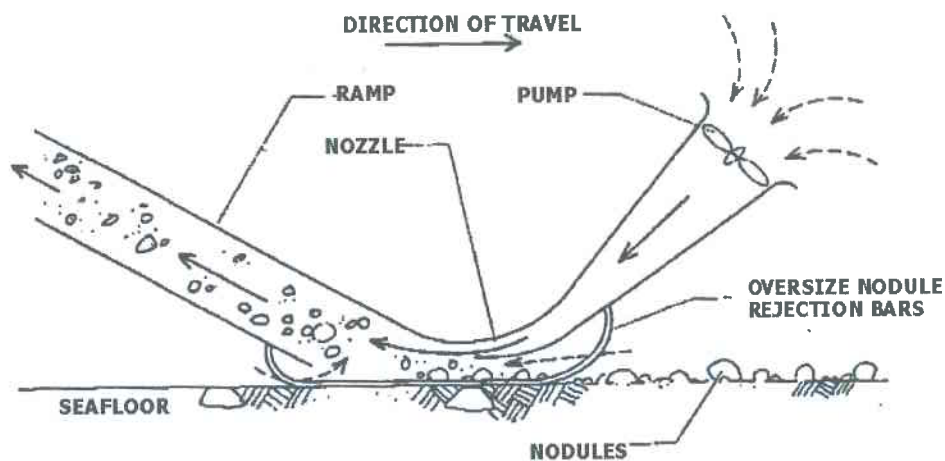

Figure 9 - Hydraulic Lift Concept

while the hydraulic ramp concept requires outboard runners or some other means of support, the base plate of the hydraulic plow concept provides all the support required. The ratio of active collection width to total collector width of this concept is therefore potentially 1: 1 which would be superior to other concepts requiring runners.

In contrast to the two previous hydraulic concepts, the solids entrance of the hydraulic life collector concept shown in Figure 9 does not make physical contact with seafloor. The primary nozzle, or nozzles, are configured so that the nodules are lifted from the seafloor by the low pressure and scouring action of the water jets. Flow from the "jet sheet" nozzles follows the contour of the curved base plate and entrains surrounding water to assist in lifting the nodules and transporting them up the ramp. Once in the ramp, the nodules and sediment are handled in the same manner as in the two previous concepts.

### **Collector Running Gear**

Ocean mining collectors can be designed with a variety of components used to support and/or propel the collector on the seafloor. The generic term "running gear" can be used to describe both passive and active elements of this type. Collector running gear has three primary functions. It supports the collector and the internal components. It allows the collector to accommodate the various bathymetric features as it moves across the seafloor. In the case of self-propelled designs, the running gear also provides the means to propel the collector.

Towed collectors are totally dependent upon the movement of the mining vessel to pull the collector across the seafloor. The effectiveness with which the collector can be steered is therefore limited. Although towed collectors are restricted to following behind the mining vessel, potential for some steerage capability does exist. This can be accomplished by the remote control of movable skegs or steerable runners. Limited steering is probably acceptable in mining operations because the intent is simply to provide enough control to maintain an efficient mining pattern. Another important characteristic of the running gear is its tracking ability and resistance to side slip when transversing slopes. Towed running gear is passive with very few or no moving parts. A major advantage of towed systems is their simplicity and inherent high reliability.

There are three basic forms of propulsion for self-propelled collectors including wheels, tracks, and archimedes screws. The potential advantage of self-propelled designs is the increased control which provides the opportunity for more efficient utilization of the mine site, increased maneuverability for obstacle avoidance, and reduced tow forces on the riser system. They have the disadvantage of

increased complexity resulting in added and more frequent maintenance and the potential for reduced reliability. They also generally increase the size, weight and power requirements of the collector.

## CONCEPT SUMMARY

The high reliability and survivability associated with passive collector concepts, and the ability of those designs to function. Without power, make them desirable for use as commercial scale collectors. Unfortunately, the very low nodule collection and sediment rejection efficiencies make them presently unacceptable for consideration in commercial mining systems. Of the concepts presented, the passive rake has the highest potential. The passive plow concept, with its excessive seafloor interaction and inherent bow wave problem, should not be considered. The rake design may warrant further investigation at a later date.

The two mechanical concepts have very high collection efficiencies making them potentially suitable for commercial operations. In order to maintain those efficiencies, however, the designs require separate hydraulic sediment separating subsystems. The concepts have the greatest number of moving parts, and are the most complicated of those evaluated. Power requirements for the two designs are similar, but are the highest of the concepts considered. The mechanical ramp design is more complicated than the drum design, but its ability to eliminate sediment is greater. Considering the number of moving elements which interface directly with the seafloor, the survivability of these concepts is somewhat in doubt. The mechanical ramp concept should be given further consideration.

The family of hydraulic collector concepts offers the most potential as commercial mining collectors. The ability of the hydraulic plow concept to perform the basic collection function is affected by the formation of bow waves which are inherent in its design. The long term endurance and physical survivability of the design are adequate, but the low collection efficiency resulting from the bow wave formation should eliminate this design from commercial scale consideration. Even if the bow wave problem could be overcome, this design picks up considerably more sediment than The other two and requires more power to function properly. The two notable advantages of this design are the ratio of its overall width to its active width, and its ability to traverse various seafloor sediments without the necessity for dredge head position control.

The effectiveness of the two remaining hydraulic concepts is very high. Both designs have minimal seafloor interaction, are generally not prone to bow wave formation, and have very high collection efficiencies. The hydraulic lift concept requires no mechanical interaction and is therefore a better design in terms of bow wave formation. The hydraulic ramp design, with slightly increased bow wave danger, has a more positive collection means, and under some conditions, could have better collection efficiency.

Because of the limited number of the moving parts and the non-complicated nature of the concepts, the endurance and survivability is excellent. The overall reliability is also potentially very high, but will depend primarily on the reliability of the pump and motor. These two hydraulic concepts require less power than the mechanical designs and require only one power source on the collector. Both the hydraulic ramp and the hydraulic lift concepts are recommended for consideration in commercial scale systems.

Both designs pick up a minimum of sediment and effectively eliminate that which is picked up. The primary oversized nodule rejection bars on the lift concept appear to be somewhat self-cleaning while those on the ramp design may require periodic combing to eliminate jammed nodules.

The substantial disadvantages associated with self-propelled collector systems outweigh the potential advantages that they offer. The added complexity, size, weight, and power requirements, the reduced reliability, and the uncertainty of their effectiveness should prevent consideration of self-propelled collectors for commercial mining systems. With the exception of reduced tow forces, which may not be significant, passively towed, steerable collector vehicles appear to offer the same advantages with no significant disadvantages.

## COMMERCIAL COLLECTOR DESIGNS

After a commercial scale collector concept has been selected, a determination of active collector width must be made. Figure 10 shows an example of a graph used to determine collector width as a function of nodule coverage, ship speed, collector efficiency, and anticipated operating time per year, all based on an annual required delivery rate of one million dry short tons (1.36 wet metric tons).

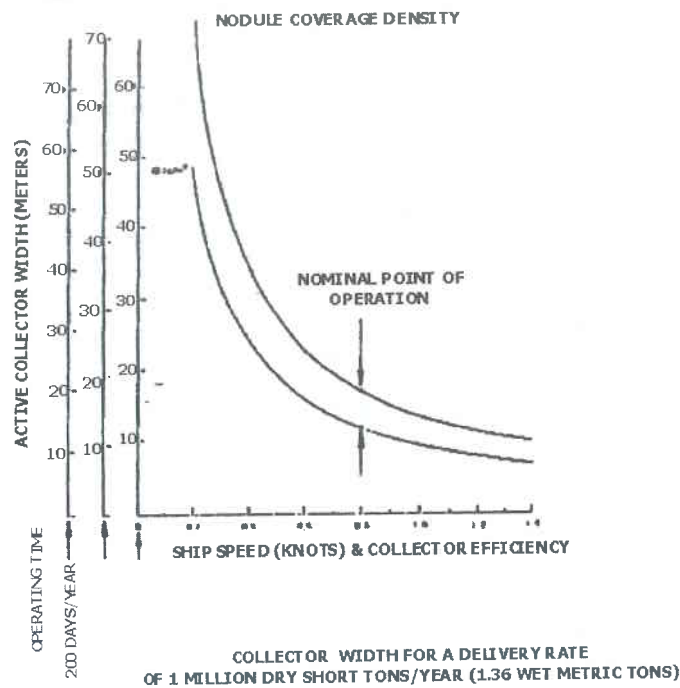

Figure 10 – Commercial Collector Width

Two examples of commercial scale collector systems are presented for consideration. These include a mechanical ramp and hydraulic lift design. Both designs are modular and are based on the concepts described previously. The primary working components of the mechanical designs are shown in Figure 11.

The concept uses a series of independent, fenestrated ramps with scraper style conveyors designed to move the nodules up the inclined ramp. Nozzles, strategically located along the ramp are used to clean the nodules of sediment. When the nodules reach the top of the ramp, they are allowed to fall onto transverse oriented mechanical conveyors for transport to a centrally located hopper leading the riser entrance. The collector can be configured so that the individual ramp units can operate and move independently in the vertical direction.

Figure 12 shows the primary working components of the proposed commercial hydraulic lift collector. Similar to the mechanical design, this concept used a series of parallel, but independent dredge heads that lead to transverse oriented conveyors. In this case, the dredge heads share a common water supply and are allowed to move independently of one another in the vertical direction. The same water source used to power the dredge heads is also used to supply



water to operate the hydraulic conveyor troughs located behind the inclined ramps. Figure 13 shows a detail perspective of the hydraulic transport conveyor.

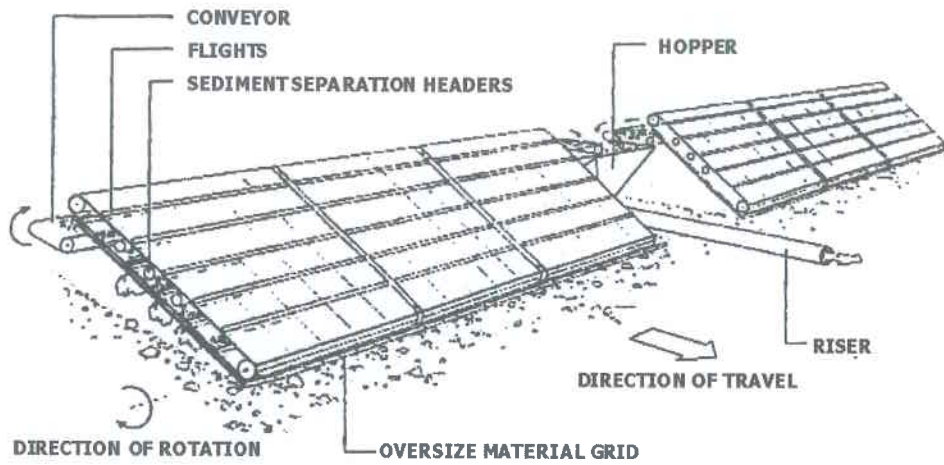

Figure 11 - Commercial Mechanical Ramp Concept

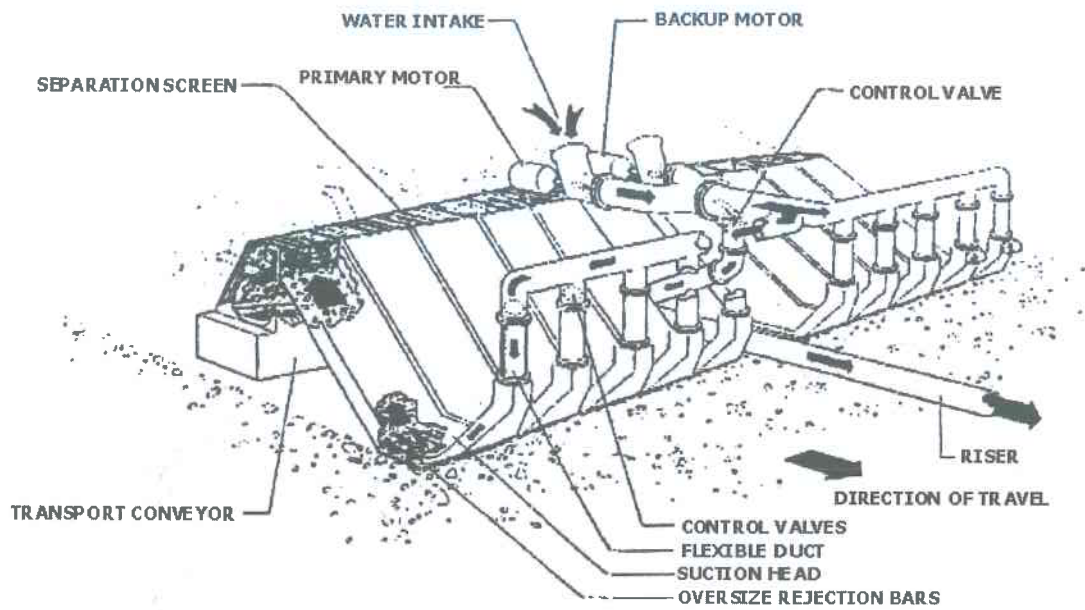

Figure 12 - Commercial Hydraulic Lift Concept

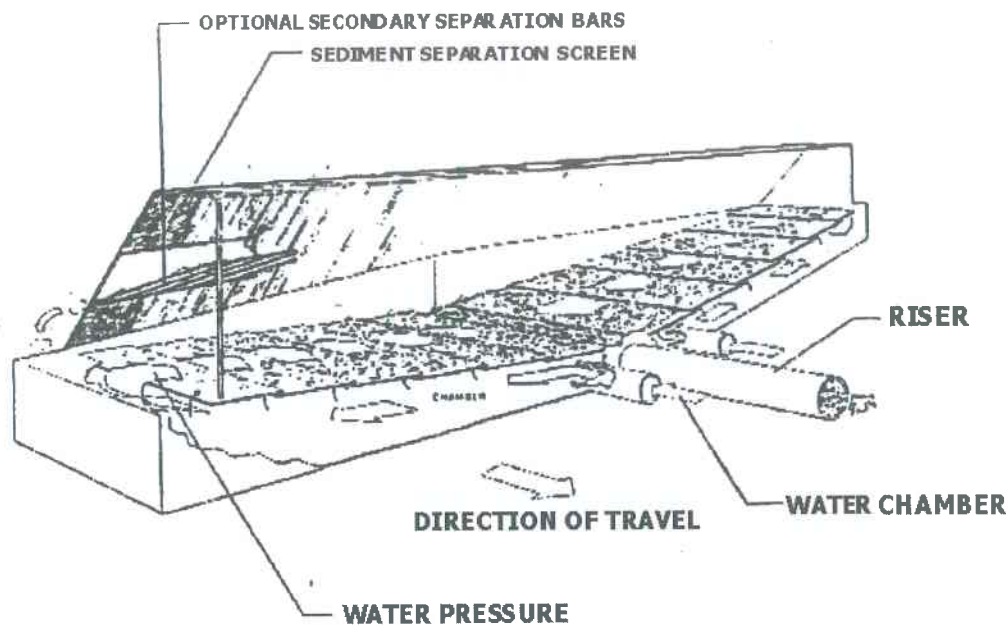

Figure 13 – Hydraulic Transport Conveyor

## CONCLUSIONS AND RECOMMENDATIONS

As indicated in the following summary sections, there does not appear to be any significant obstacle preventing the development of either hydraulic or mechanical ramp collectors for use as commercial systems. From the standpoint of collector size, weight, power, and handling requirements there is no substantial difference between the two designs. The two considerations that should significantly influence the decision to use either design are system reliability and maintainability. Based on simplicity of design and minimal number of moving machine elements, the hydraulic collector appears to have a greater potential for high reliability, long term endurance, and minimal maintenance.

### Collector size and weight

The length and width dimensions of the hydraulic lift and mechanical ramp collectors appear to be approximately the same, 18-19 m long, and 30-31 m wide. It is anticipated that the hydraulic lift collector will weigh less than the mechanical design.

### **Collector modularization**

The number and size of active collection components should be established for each collector on the basis of maximizing operational flexibility and system redundancy, while minimizing complexity and the impact of component failure. For both designs, and particularly for the hydraulic lift concept, the number of components can be modestly changed without major impact on the system.

### **Components performance and endurance**

Many of the critical components of the two collector designs such as pumps, motors, drive trains, etc., are commercially available. Some of these items, however will require modification in order to become usable for the particular application being considered. With or without modification, and whether or not the items are commercially available, their performance (and long-term reliability characteristics must be determined and suitably modified for commercial operations. A major advantage of the hydraulic lift collector is the simplicity of its power supply system motor and pump. No other components are required. Back up systems are also easy to incorporate into the hydraulic lift collector with a minimal increase in system complexity.

### **Instrumentation**

The instrumentation system will play a critical role throughout the development of commercial collector concepts. Collector instrumentation will be the primary means for obtaining the data required to evaluate the performance of the collector during *in-situ* operations. A reliable system containing back up components for critical parameters is essential.

It should be clear from the above conclusions that a considerable amount of information about the performance and reliability of the two designs and their components is required before a commercial operation should be undertaken. To obtain the necessary data, a development programme containing land-based tests, *in-situ* tests (optional), and pre-commercial tests is recommended. A brief description of the three test phases and their objectives follows.

### **Development Plan**

The development of commercial-scale collectors will require an organized plan designed to efficiently carry the collector or collectors from concept through to commercial-scale construction and test. While concepts based on proven technology may require relatively little effort, new concepts will require significant effort.

The following general programme is suggested as a guide to the development of new concepts.

Any collector programme will be initiated with the development of the conceptual design. The concept can generally be divided into basic components such as the dredge heads or collection means, the conveyor or transport means, the over-size and sediment rejection devices and the running gear, etc. Once the basic components have been identified, full or scale models can be constructed for laboratory testing. Even full-scale components can be easily tested in a laboratory environment if only a small section of the component is determined to be representative. The obvious advantage of conducting preliminary tests in a flume or small tow tank is the ability to control the environmental as well as the test parameters. As an example, in the early INCO collector development programme, models of jet sheet nozzles and inclined ramps were tested to determine the nozzle velocities required to transport nodules up inclines and across conveyor troughs. The tests were relatively inexpensive to conduct yet they yielded valuable information about the basic requirements of hydraulic collection and transport devices.

A detailed design phase should follow the laboratory component tests and should incorporate the results from those tests. It is assumed that any ocean mining development programme will probably include a pilot mining phase and that fully functional pilot scale collectors will be required for that programme. It is suggested that an interim "*in-situ*" collector test programme be conducted prior to the pilot mining tests.

Consideration should also be given to conducting pilot mining scale collector tests in shallow water (tidal zone mud flats) or a purposely built test facility. A purposefully built test facility can be cost effectively constructed by excavating a large trench in a gravel pit or similar location. The floor of the test pit can be covered with simulated sediment made on site or transported in by truck from another location. Simulated nodules can be readily constructed using light weight concrete that has been broken and tumbled to remove the sharp corners. Here too, the advantages of conducting tests in a controlled environment are obvious. They are also substantially less costly than conducting tests at sea.

Because of the very high costs associated with even a pilot mining operation, it is essential that "*in-situ*" collector tests be conducted to prove and refine the collector design. Collectors can easily be tested from a research type vessel by attaching them to the end of an electro-mechanical cable and lowering them to the seafloor. The design of the test collector can be modified to discharge the collected nodules back to the seafloor instead or into a non-existent riser system.

Pilot mining operations are the only true way to determine the effectiveness of the collector in combination with the complete mining system. Because of the high cost of the large drilling vessel required for such tests, all system components including the collector system or systems must be thoroughly tested prior to the pilot mining test.

## Summary of the Presentation and Discussions on Nodule Collector Subsystems II

Mr. Brockett introduced his paper by showing a 15 minute video of the OMI field operations in 1978 and his oral presentation was illustrated by 27 slides. He thoroughly detailed his experiences in 1978 of OMI's laboratory and deep seabed testing operations to compare some eight different collectors. Passive collectors tested included a rhomboid rake, a hybrid passive rake using a wash and transport water intake powered by the forward movement of the machine, and a passive inverted flow system which planed off and cleaned the first ten cm or so of the deposit. In general, he said, the passive systems are simple but unacceptable, largely because the sediments are cohesive and stick to the nodules and the machines and form massive bow waves. These add to the energy required for pick up and result in significant loss of nodules in the sediment masses that are bypassed by the collector. Examples of active mechanical and hybrid concepts tested included a mechanical drum, a mechanical ramp, an hydraulic ramp, an hydraulic plow and an hydraulic lift. The purpose of the collector is to gather the nodules and deliver them, bereft of sediment, to the intake of the vertical transport system. Of the designs tested, the simple rake, and the hydraulic ramp and lift appeared to offer the most potential as simple commercial systems. The two mechanical concepts had very high collection efficiencies but many moving parts and required separate sub-systems for sediment removal. For a commercial system, collector width is a critical factor and is a function of nodule coverage, ship speed, collector efficiency and anticipated operating time, which for OMI, was based on an annual production of one million dry short tons. The speaker briefly discussed traction devices which included towed skids, wheels, tracks and Archimedes screws. All systems should be thoroughly tested on land at pilot and prototype scale before submitting them to the high cost of testing *in situ*. Pilot mining tests at sea are, however, the only way to determine the effectiveness of the total system. With the advancement of technology over the past twenty years, it is easier today than ever before, the speaker said, to accomplish the required tasks necessary to successfully mine the sea floor.

Questions from the floor centered mostly on engineering issues, the efficiency of the pump system, vs the airlift, details of the airlift, the pick up efficiency vs collector speed, the need for technology breakthroughs and sensing and control of the collector on the seabed. The speaker responded fully to these issues with some interesting anecdotes along the way.

## **Pump v Airlift**

Mr Brockett informed the workshop that tests were made of both a pump system and an airlift. The pump system was similar to that described by Professor Schwarz with three submersible pumps in line. They worked well but even in the short test that gathered about 1000 tonnes of nodules, substantial wear on the pumps was indicated when they were dismantled.

Mr. Brockett further informed the workshop that the air lift is a simple concept where air is injected into the line to lower the density of the slurry and induce a flow as a result of the difference in pressure in the pipe and at the pipe inlet. Injection at a depth of 6000 ft, however, required the installation of very large compressors on deck to supply air at 3,000 psi, and the attachment of a separate, very high pressure pipeline to the riser string for the injection. The system was not fairly tested, however, because during the lowering for a third test, a pipe joint failed and carried the collector and ancillary pipes and cable to the bottom. Failure was not infrequent and almost every phase of development incurred some significant loss.

Regarding the very high pressure used, the speaker said he was not familiar with the Deep Sea Ventures injection at 600 ft, as this part of the work was supervised by SEDCO, the drill ship contractors. His company worked closely with KSB, the German manufacturers of the pump system.

In response to a question about the safety of the very high pressure air used Mr. Brockett indicated it was outside his area of expertise but related that standing on the top deck on the rig floor where the air/ water separator was located, while using the air injection system, was like standing two inches from a freight train going at 90 miles an hour. The volume of air, water and nodules coming into the separator made an incredible noise, and it was frightening. Another potential hazard that had not yet been resolved was the effect of a sudden detachment of the 20 million pound (10,000 tons) riser string on the stability of the vessel. On one of the tests a complete loss of vertical control on the derrick had been experienced causing it to suddenly flop over to the side which was very scary and brought to mind the other possibility.

## **Improvements in technology**

Responding to queries on improved technology required for economic recovery, Mr Brockett indicated that electronic advances such as instrumentation, monitoring, data transfer, control capabilities, and positioning had greatly improved and would result in reduced costs. The two major design problems that had not yet been fully resolved were the collector and the submersible pumps. The remoteness of the collector required that it be reliable in the long term and therefore

as simple as possible. Redundancy of subsystems was also important so that a component failure did not necessarily affect the total system. On one of their test collectors the only moving part was a single electric motor, which did, in fact, fail. Pumping systems had generally improved and he still believed the submersible pump was superior to other lifting methods.

### **Collector Speed v Pickup Efficiency**

The effect of collector speed on pickup efficiency was briefly discussed. Mr. Brockett informed participants that the design speed for OMI was one knot during testing but was exceeded at times. The effects of speed will be dependent also on the velocity of water jets, the abundance of nodules and the ground characteristics. Speed should really be adjusted to match nodule abundance, which could vary between 10 and 40 kg/square meter, so that other parts of the system receive a steady input. The difficulty had been to measure the abundance in real time. OMI measured the nodule input to the riser pipe but there was a twenty minute time lag to verify at the surface. This would probably not be a problem with the sensors available now. Other participants indicated that their testing showed a significant drop in efficiency with increased collector speed, sometimes due to the sediment build-up on the machine. This whole issue was closely tied to the question of detailed site mapping and mining control raised in the discussions after Professor Schwarz' presentation.

### **Future mining**

On a prognosis for the future, Mr. Brockett was quite positive that the technology was available now to successfully produce nodules but he was less optimistic on the economics of deep seabed polymetallic nodule mining. This factor may not be of such importance, he said, in state-controlled operations where the priorities may be different.





## Chapter 4

# FUNDAMENTAL STUDY FOR THE DEVELOPMENT OF A COLLECTOR SUB-SYSTEM AND ITS FUTURE TECHNOLOGICAL NEEDS

*Mr. Katsuya Tsurusaki*  
*Japan Environmental Management Association for Industry*  
*Tokyo, Japan*

**Abstract**

**Introduction**

**Geotechnical Properties of Deep-sea Sediments and Nodules**

**Relationship Between Geotechnical Properties and Collector**

**Performance**

**Japan's Collector and its Deep-sea Test**

**Breakthrough Needed for Future Collector Development**

**Acknowledgment**

**References**

**Summary**

## ABSTRACT

A review of a fundamental study in deep-ocean mining technology, especially on the development of the nodule collector sub-system, is presented in this paper. The geotechnical properties of deep-sea sediments and polymetallic nodules affect collector performance very much. So, it is important to clarify the relationship between them. In this paper their natural properties are described first and then the relationships between those properties and collector performance are described. Then the collector developed by Japan and its deep-sea test are introduced briefly. Lastly, some breakthroughs needed for future mining technology is discussed.

**Key Words:** Deep-ocean mining, polymetallic nodules, deep-sea sediments, collector sub-system, geotechnical properties, deep-sea test

## INTRODUCTION

In Japan, the National Institute for Resources and Environment (NIRE) and the Deep Ocean Minerals Association (DOMA) initiated studies on polymetallic nodules mining technology in the 1970s. NIRE studied the fundamental aspects of several mining methods. DOMA's effort was primarily directed toward developing an efficient mining concept. On the basis of these preliminary studies, in 1981, the Ministry of International Trade and Industry (MITI) decided to pursue further R&D of the mining concept as one of the national programmes directed by the Agency of Industrial Science and Technology (AIST).

In this programme, studies were carried out by NIRE, while engineering work was conducted by the Technology Research Association of Ocean Mineral Resources Mining System (TRAM) under the management of the New Energy and Industrial Technology Development Organization (NEDO).

Reliability, mobility, safety, and collection efficiency of the nodule collector are the most important parameters in the mining system. Geotechnical properties of deep-sea sediments and polymetallic nodules are key design factors for the collector. Static properties of the sediments and nodules were studied on board a survey vessel and in the institute's laboratory (Handa and Yamazaki, 1986; Tsurusaki et al., 1994; Yamazaki et al., 1995b), and an *in-situ* measurement system was also developed (Tsurusaki et al., 1984). On the basis of these results, drag resistance of the

collector on the sediments and nodule pick-up force from the sediments has been estimated (Yamazaki et al., 1~89). As the dynamic properties of the sediments at collector touch-down onto the sea floor are a very important design factor for the collector frame structure, a measurement method was developed and the dynamic moduli of elasticity and viscosity were calculated (Yamazaki et al., 1995b; Yamazaki et al., 1995d). These studies have been conducted as research on the relationship between geotechnical properties and collector performance.

As a result of the cooperative research on fundamental studies and technology development efforts, a collector sub-system was designed and manufactured and a deep-sea mining test was conducted in 1997.

## **GEOTECHNICAL PROPERTIES OF DEEP-SEA SEDIMENTS AND NODULES**

Reliability, mobility, safety, and collection efficiency of the nodule collector are the most important parameters in the mining system. Geotechnical properties of deep-sea sediments and polymetallic nodules are key design factors for the collector.

### **Geotechnical properties of deep-sea sediment**

The deep-sea sediment properties are fundamental parameters for nodule collection mechanism and collector manoeuvrability. Static properties of the sediments and nodules were studied on board a survey vessel and in the Institute's laboratory.

The measured items were particle size distribution, water content, consistency, original and remolded vane shear strength, cone penetrating resistance, uniaxial strength, tri-axial strength etc. Some of those were measured at several centimeters depth along the sediment column, from the surface to 0.4 m depth in a box core sample on board during the exploration cruise.

Figure 1 shows examples of the results of particle size distribution measurements and Figure 2 shows the consistency chart which classifies the characteristics of the cohesive soil (Yamazaki et al, 1995). These figures indicate that the deep-sea sediments at the site consist of clay and silt particles, without sand size particles and are classified in the organic clay with high compressibility. The same tendency of the particle size distribution at different depths means the sedimentation environment is constant for a long time.

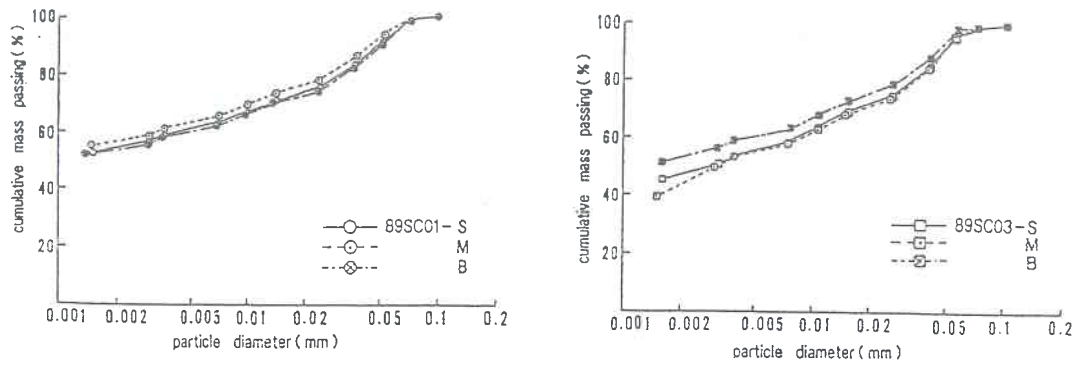

Figure 1 - Size distribution of deep-sea sediments

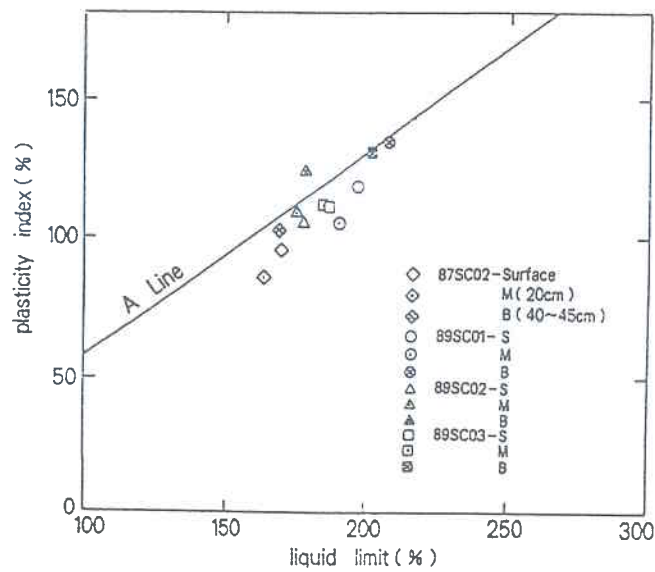

Figure 2 - Consistency chart of deep-sea sediment

In the case of clayey sediments, the most representative value of sediment strength is vane shear strength. Sensitivity is also known as an important factor for characterization of strength reduction of clayey sediments. Examples of the on-board measurement results are shown in Figure 3 and their average values are listed in Table 1.

**Table 1**  
**Geotechnical properties of deep-sea sediments**  
**(average, on board measurement)**

Depth (cm)	Vane Shear Strength (gf/cm <sup>2</sup> )						Sensitivity	Cone penetrating resistance (gf/cm <sup>2</sup> )			Water content (%)			
	Undisturbed			Remolded				Ave.	Ave.	Max.	Min.	Ave.	Max.	Min.
	Ave.	Max.	Min.	Ave.	Max.	Min.								
4	14.3	28.3	6.1	4.8	8.5	2.7	3.0	68	156	40	293	353	200	
10	26.0	38.2	18.4	8.5	11.9	5.1	3.1	165	227	100	257	304	221	
16	31.1	47.7	14.3	10.5	16.0	4.8	3.0	194	245	97	250	335	191	
22	34.5	58.7	11.9	12.4	22.5	5.1	2.8	243	332	90	239	300	176	
28	35.4	52.9	14.3	13.9	25.9	6.5	2.6	277	330	120	231	291	168	
34	30.0	36.5	15.7	11.6	16.4	6.8	2.6	246	298	130	212	254	150	
40	30.2	36.5	17.7	11.2	13.3	7.8	2.7	205	313	125	211			

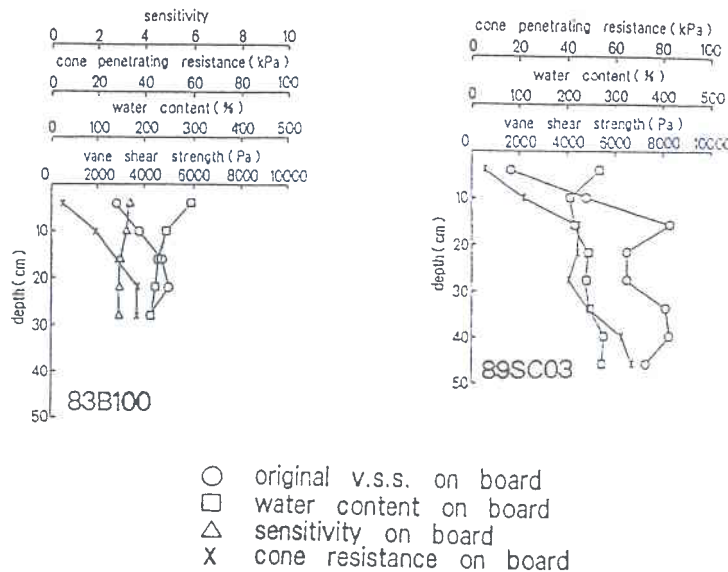

Figure 3 - Geotechnical properties of deep-sea sediments (on board measurement)

Figure 4 shows the relationship between the vane shear strength and the uni-axial strength. The results of tri-axial tests are shown in Figure 5 in which the internal friction angle is nearly equal to zero. These data indicate that the deep-sea sediment can be characterized as very weak and very sensitive clay. It is also indicated that the uni-axial strength has a linear relationship with the vane shear strength that and the vane shear strength can be recognized as the index of the strength of the deep-sea sediments.

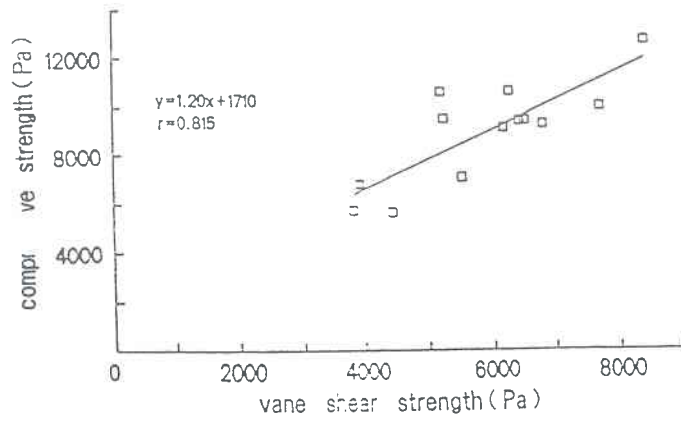

Figure 4 - Vane shear strength and uni-axial strength of deep-sea sediments

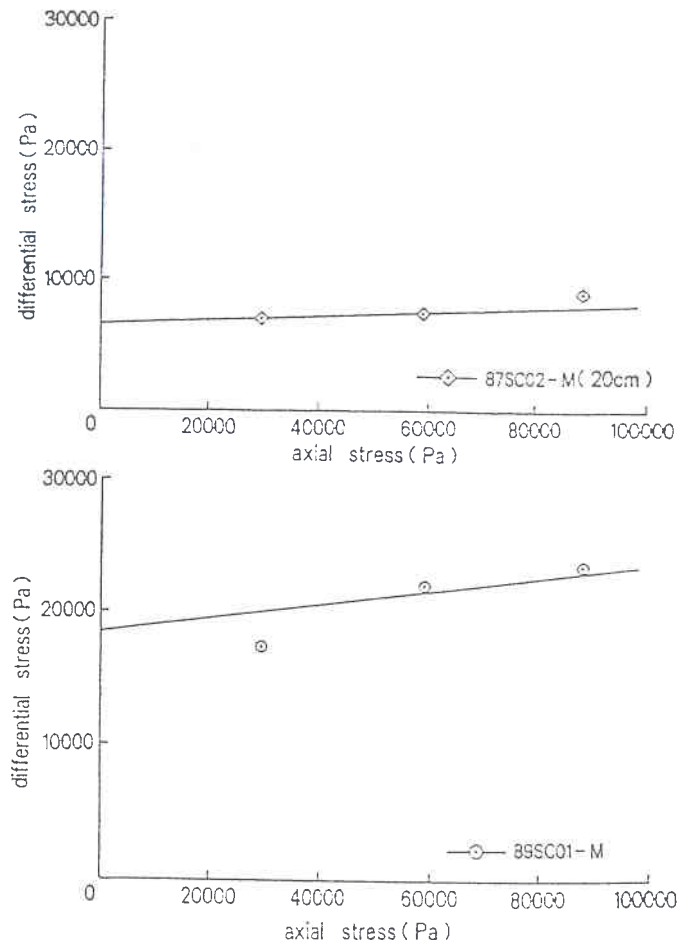

Figure 5 - Results of tri-axial U-U test of deep-sea sediments

## Engineering and distribution characteristics of nodules

Polymetallic nodules are widely distributed on the ocean floor at depths of 4,000 to 6,000 m, and the Clarion-Clipperton area in the central east Pacific Ocean is known for its high abundance of nodules and high contents of valuable metals. Engineering and distribution characteristics of deep-ocean polymetallic nodules are also much desired information for collector sub-system development.

The abundance and size distribution of nodules affects the design of the collector sub-system. This information is essential for the design of the seafloor collector intake device and collection efficiency. The internal slurry flow including nodules and sediment lumps can also cause problems with throughput efficiency and potential clogging. These nodules are generally about 1 to 15 cm in diameter and half buried in deep-sea sediments. Large nodules may be either rejected or crushed.

The abundance and size distribution were measured on the survey cruises in the Pacific Ocean. The frequency distribution of nodule abundance is shown in Figure 6.

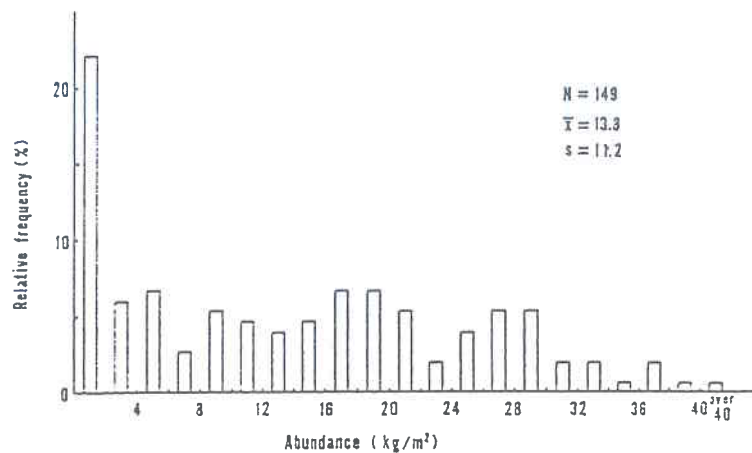

Figure 6 - Frequency distribution of nodule abundance

The mean long-axis length, short-axis length, thickness and weight measured on more than several thousands of samples were 5.5 cm, 4.4 cm, 3.4 cm, and 95.7 g, respectively, and the corresponding standard deviations, 1.8, 1.5, 1.2, and 86.6 respectively. The frequency distribution of the nodule long-axis length is shown in Figure 7 (Yamazaki et.al, 1990).



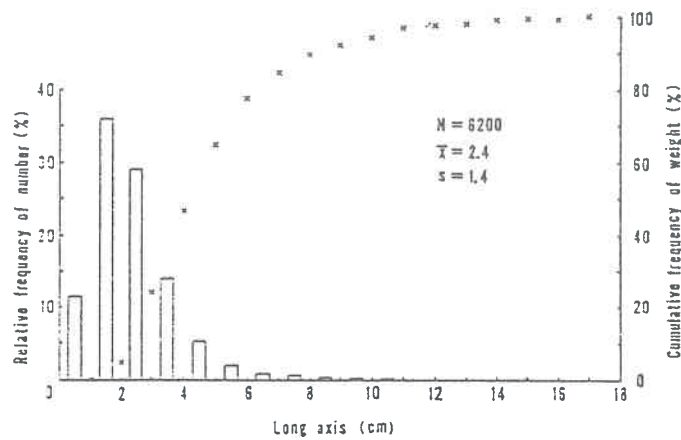

Figure 7 - Frequency distribution of nodule size

Mechanical strength is also obtained from nodule samples. The surfaces of nodules are easily breakable when preparing a standard-shaped test specimen, and it was difficult to perform conventional material tests to measure the strength characteristics. Therefore, the unshaped-uni-axial compressive test was performed with nodule samples of natural shape. The weight and size of the sample nodule influenced the strength values of the test. The strength values from the test specimen of 30 to 40 g in weight (wet) of nodules appear to be close to conventional uni-axial compressive strength. The test results were analyzed to get normal compressive strength (Figure 8).

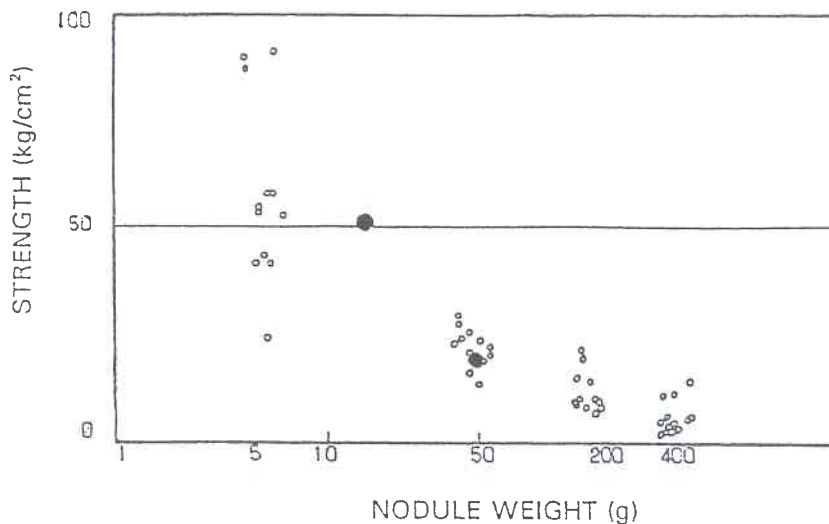
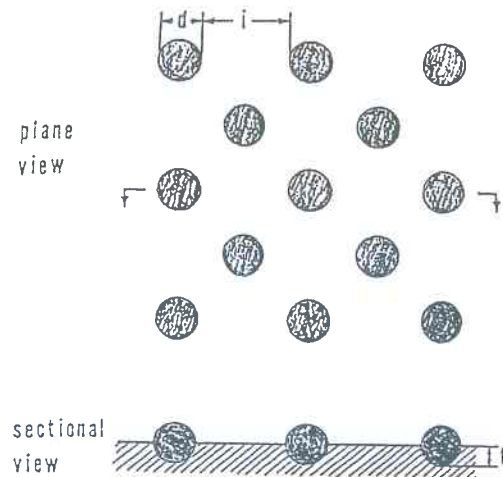

Figure 8 - Uni-axial strength of nodules

In figure 8, large solid dots indicate the average values of the previous test results (TRAM, 1984). The uni-axial compressive strength of the polymetallic nodule samples range between 3 and 5 MPa.

In accordance with the exploration results of the Clarion-Clipperton Zone, first generation commercial nodule mining is expected in areas which have 10kg/m<sup>2</sup> in average nodule wet abundance. Figure 9 shows a simple model of such nodule distribution. The coverage of nodules is only 15% in the area.



d : diameter	= 5.0 cm	$\rho_n$ : nodule density	= 2.0 g/cm <sup>3</sup>
i : interval	= 11.2 cm	(bulk, wet)	
t : depth	= 2.5 cm	$\rho_s$ : sediment density	= 1.3 g/cm <sup>3</sup>
		(bulk, wet)	
c : coverage	= 15.0 %	a : abundance	= 10.0 kg/m <sup>2</sup>
		(wet)	

Figure 9 - Nodules distribution model on the deep-sea floor

The importance of the geotechnical properties of deep-sea sediments on nodule collector design is easily recognized from the figure.

## RELATIONSHIP BETWEEN GEOTECHNICAL PROPERTIES AND COLLECTOR PERFORMANCE

It is necessary to clarify the relationship between the geotechnical properties of deep-sea sediments and nodules and collector performance for appropriate design of the collector with high efficient collection, stable and safe manoeuvrability, etc. The basic concept of Japan's collector is towed sledge-type framework with

hydraulic collection. The study for dynamic geotechnical properties of deep-sea sediment and nodules was conducted from this point of view.

### Collector manoeuvring

According to the adaptation of the towed sledge type framework for Japan's collector, the dynamic geotechnical properties between sediments and solid objects were studied in two cases (Figure 10). One case was for the collector's traveling capability along the seabed laterally. The other was for touch down of the collector onto the seabed vertically.

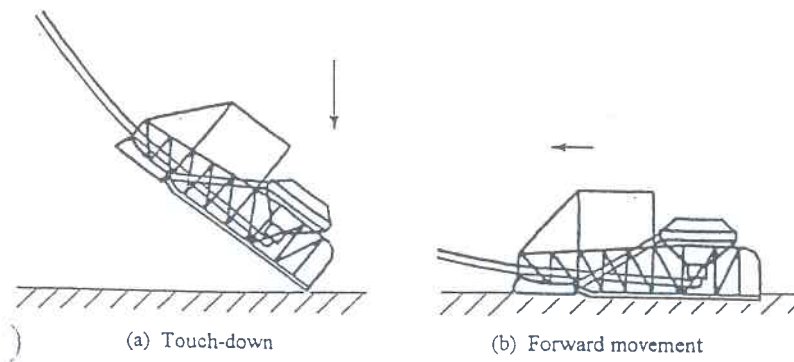

Figure 10 - Two cases of dynamic behaviour of collector on sea floor

During collector towing, the lateral drag force depends on the resistance generated by the relationship between collector and the deep-sea sediments. This resistance is estimated from the sum of three components; friction resistance, cutting resistance, and adhesive friction. Friction resistance is generated by contact pressure between the collector and the sea floor, cutting resistance is generated by rejecting molded sediment in front of the collector, and adhesive friction is generated through the contact area of the collector and sea floor. Adhesive resistance is the peculiar characteristic of clay. The total resistance is obtained by the following equation.

$$F_t = f(F_f + F_c + F_a) = f(k_f \times p \times A + k_c \times c \times S + k_a \times c \times A)$$

where  $F_t$ : total resistance,  $F_f$ : frictional resistance,  $F_c$ : cutting resistance,

$F_a$ : adhesive resistance,  $k_f$ : frictional coefficient,  $k_c$ : cutting coefficient,

$k_a$ : adhesive coefficient,  $p$ : contact pressure,  $A$ : contact area,

$S$ : cutting area,  $c$ : shear strength represented by vane shear strength

These coefficients are clarified as  $k_f$ : 0.12,  $k_c$ : 8.2,  $k_a$ : 0.08 (Yamazaki et al, 1990) through laboratory experiments whose concept is shown in Figure 11 as an example.

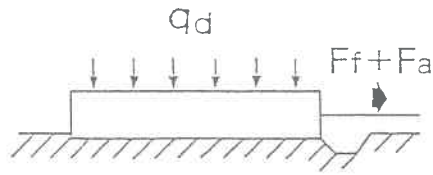

Figure 11 - Concept of drag force measurement

Touch down of the collector onto the sea floor is only once per a certain period of the mining operation. It, however, would be one of the most sensitive operations of the mining system. Any kind of failure of the equipment caused by the touch down shock would result in the need for retrieval of the collector. There has been no method to clarify the dynamic properties such as abrupt impact-like touch down for very weak and sensitive clay. A new method has been developed to find the modulus of elasticity and viscosity of deep-sea sediments. The test concept is shown in Figure 12 and the results of the tests are also shown in Figure 13.

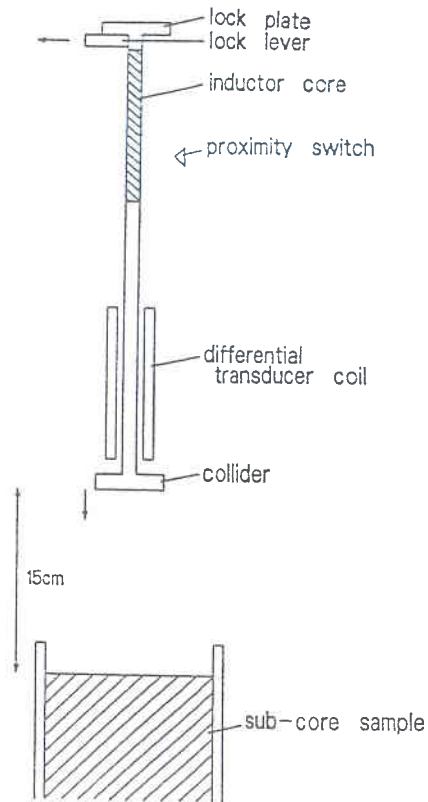

Figure 12 - Schematic view of collector test on sub-core sample of deep-sea sediments

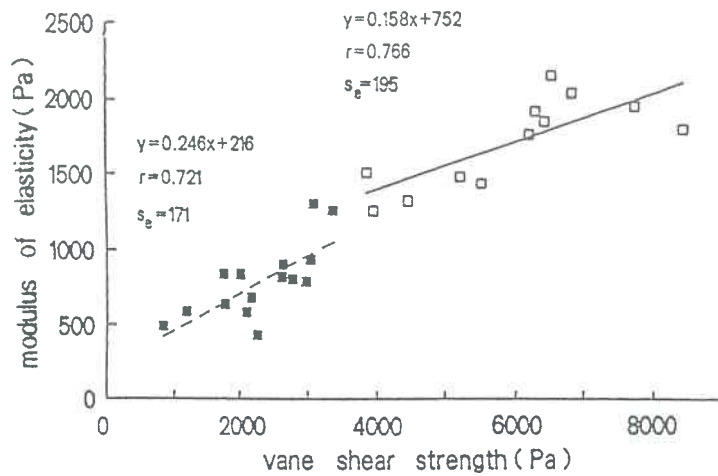

Figure 13 - Vane shear strength and moduli of elasticity

### Collection mechanism

A hydraulic nodule suck-up device was adapted for Japan's collector in the pilot mining test because its high collection efficiency and reliability were recognized in the scale model tests. Figure 14 shows the fundamentals of the collection mechanism.

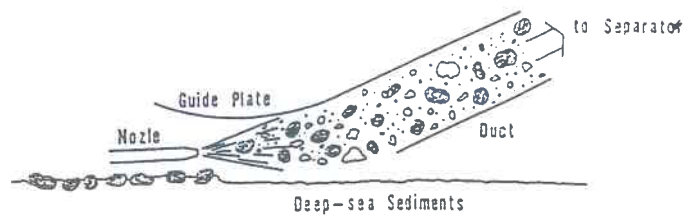

Figure 14 - Principle of hydraulic suck up device

The source of the nodule's suck-up force is the negative pressure created by the reduction of the flow section area of the pressurized water stream based on the Coanda effect.

Nodule pick-up force, which is sum of nodule weight and adhesive resistance generated by the deep-sea sediments, was measured on box core samples on board. Figure 15 shows the measured results of nodule pick-up resistance per unit projection area of nodules from the sediment surface.

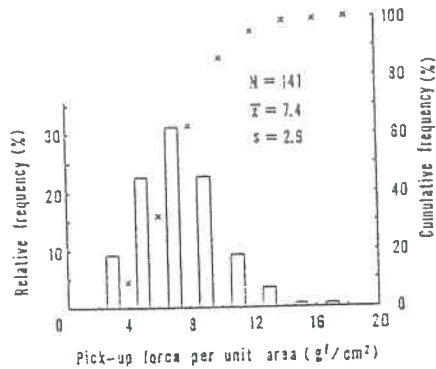

Figure 15 - Frequency distribution of nodule pick-up force

Large amounts of deep-sea sediments were also sucked-up with nodules by the hydraulic suck-up device. Sediment intake tests were also conducted using a laboratory apparatus (Figure 16).

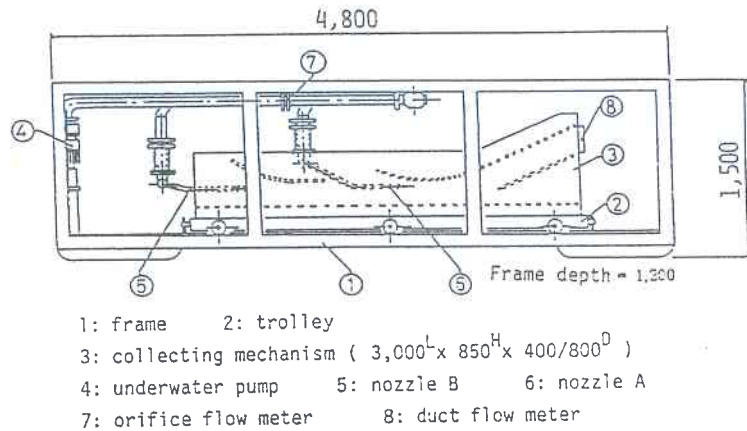

Figure 16 - Laboratory apparatus of study of collection mechanism

Figure 17 shows the observed number of sediment lumps in the duct.

Because the suck-up part of the laboratory apparatus didn't travel over the sediment layer in the laboratory test and the sediment layer was an artificial one, the result was insufficient. But the size information of sediment lumps is very important

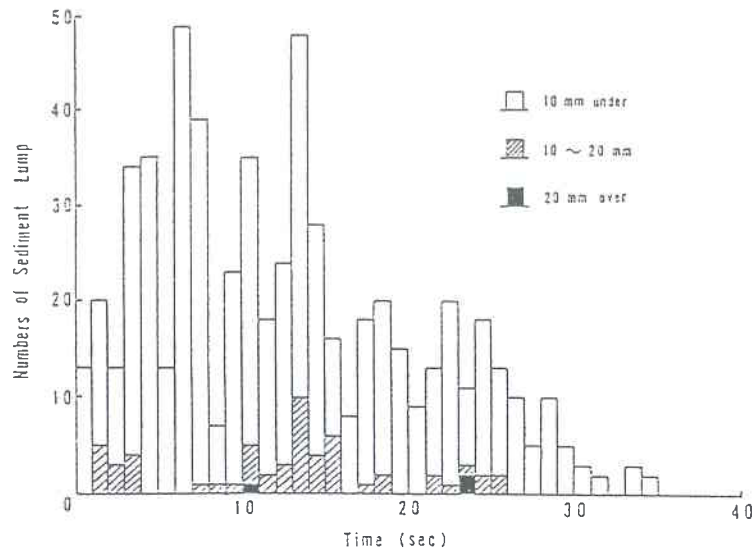

Figure17 - Frequency distribution of sediments lump sucked-up

## JAPAN'S COLLECTOR AND ITS DEEP-SEA TEST

As a result of fundamental studies and technology development, a test collector was constructed. A comprehensive mining test was planned with the complete system at the early stage of the project (Figure 18).

As a result of difficulties, the mining test was modified in scale and system configuration. The deep-sea test with the developed test collector was conducted on a seamount in the central north-western Pacific Ocean in 1997 to make sure of its performance. Dr. Yamazaki will present the details of the deep-sea test at this workshop.

### Test collector

Figure 19 shows the test collector constructed for the mining test. It measured an overall length of 13.2 m, width of 4.6 m and height of 5 m.

It was supported with five sledges and equipped with four units of suck-up and intake devices between sledges. The designed collecting capacity was as much as 125 tons of polymetallic nodules per hour. It was originally designed and developed for the comprehensive ocean mining test and was able to feed nodules continuously to the lift sub-system through a nodule crusher and feeder. It was modified for the deep-sea mining test.

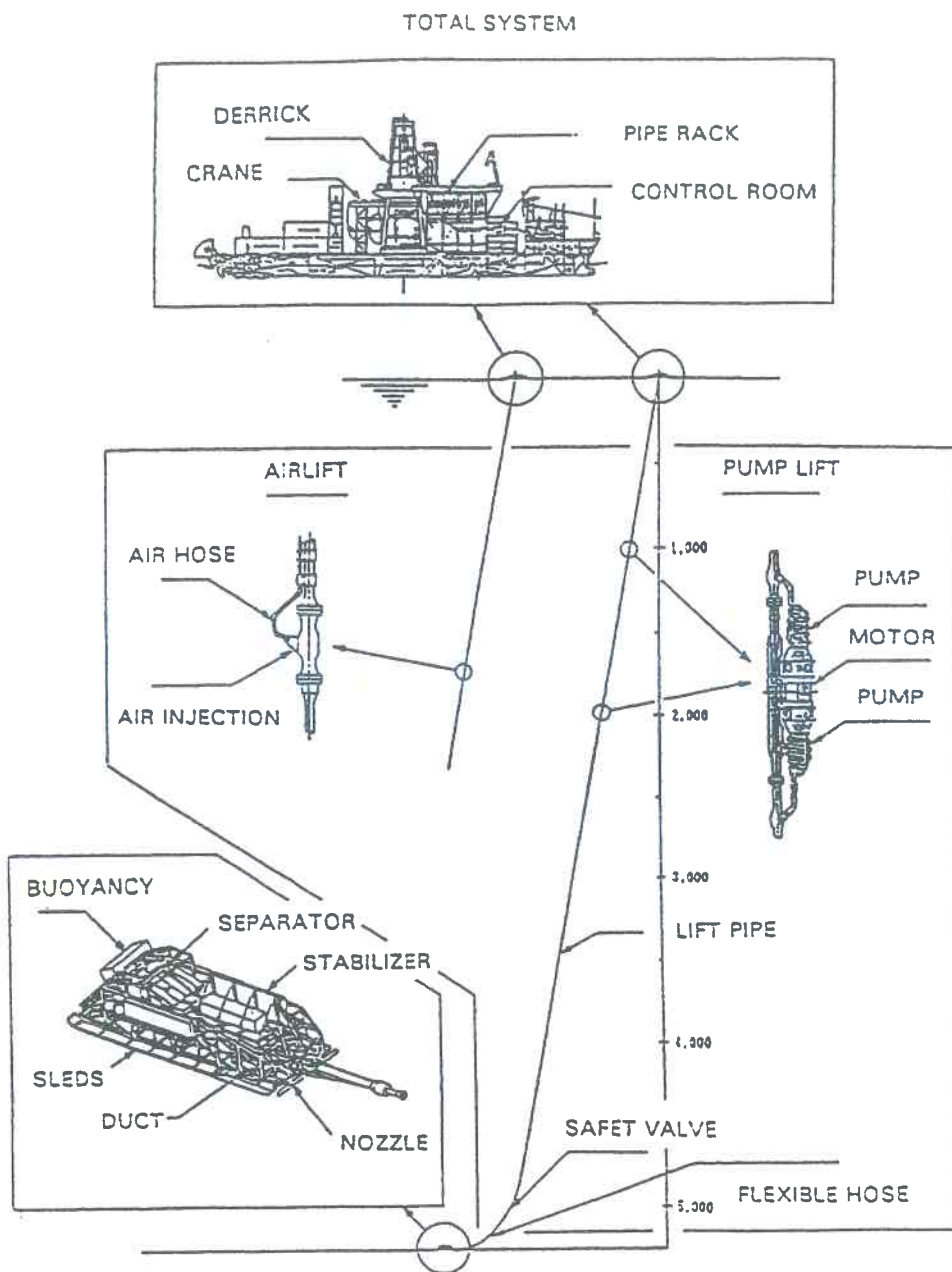

Figure 18 - Concept of comprehensive deep ocean mining test



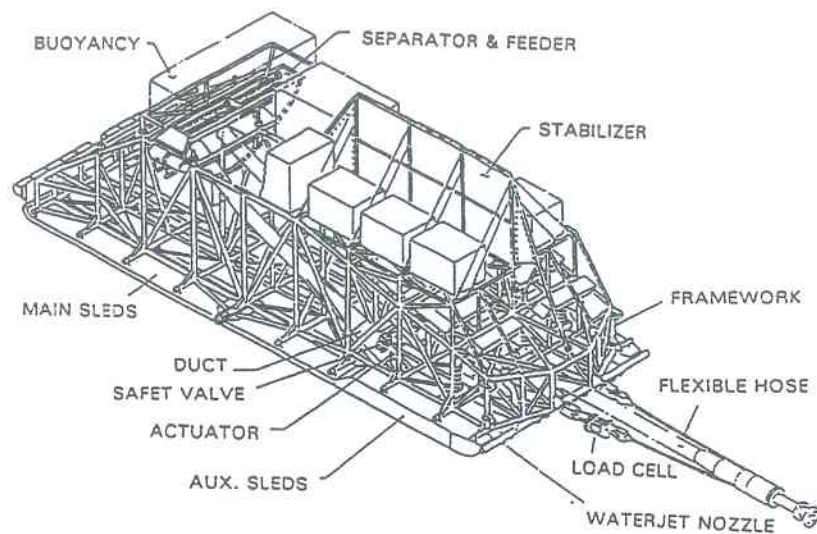

Figure 19 - Collector sub-system designed and constructed for deep ocean mining test

### Deep-sea test

The test was carried out in a narrow terrace-like area on the top of a seamount in the central north-western Pacific Ocean. The depth of water was about 2,200 m and the mean density of polymetallic nodules of 15.6 kg/m<sup>2</sup> is distributed on thin foraminiferous sediments whose geotechnical properties are much different from the deep sea sediments.

The components of the test system consisted of a 122 m long and 32 m wide mother vessel the test collector, a hybrid deep-sea cable with optical fibres and power cables, a high-precision, super-short, base line underwater positioning system, and the differential global positioning system for mother vessel and tugboat navigation.

### Results of the test

The mining test was conducted twice with mining distances of 215 m and 320 m. The collection efficiency, which was estimated from the amount of collected nodules, the distribution density of nodules in the area, the mining distance, and suck-up device width, was 87%. The towing speed of the collector fluctuated between 0.3 and 0.8 knots during mining. The behaviour of the collector during towing was stable and it had no significant effect on the collection efficiency. The two tracks of the collector were observed by a ROV about one month after the mining test. TV images and many photos were obtained during observations, not only

along but also around the tracks. Detailed comparisons between the visual image and the acoustically-measured track is useful not only for the data analysis of the mining test but also some simulations of collector movement.

## **BREAKTHROUGH NEEDED FOR FUTURE COLLECTOR DEVELOPMENT**

In mining technology, the collector or the miner efficiency is the biggest problem to be solved. For increasing collector efficiencies there are two ways. One is to increase sweep efficiency and the other is to decrease the down time of the collector.

To increase the sweep area a self-propelled mechanism needs to be developed. It is very hard technology required to self-propel in the very soft and sensitive deep-sea sediments. In addition to this, high performance equipment to avoid obstacles on the sea floor autonomously needs to be developed. This equipment shall be a high, accurate acoustic device which can sense the obstacles in a very noisy environment where noise is emitted from the many pieces of equipment in the collector sub-system and ore lift sub-system.

To decrease the down time of the collector the total reliability of the instrument is most important. It takes much time to retrieve and then deploy the underwater components for reasons of technical troubles of machinery. In addition to this, the appropriate avoidance methods from stormy weather need to be developed from the viewpoint of hardware and software.

To increase total efficiency, some buffer-like sub-system, needs to be installed between the collector and lift sub-system, to control and observe the collector performance and to prepare and adjust the condition of the slurry fed to the lift sub-system.

## **ACKNOWLEDGMENT**

The author gratefully acknowledges the Ocean Development Office of the Agency of Natural Resources and Energy and NIRE's research team, especially Dr. Yamazaki, for providing their support in the preparation of this presentation. The author also gratefully acknowledges the International Seabed Authority for providing this opportunity to present the paper.

## REFERENCES

- Handa, K, and Yamazaki, T (1986). "Physical and Engineering Properties of Manganese Nodules and Deep-sea Sediments in the GH81-4 Area," in Nakao, S, ed, *Marine Geology, Geophysics, and Manganese Nodules around Deep-sea Hills in the Central Pacific Basin, August-October 1981 (GH81-4 Cruise)*, pp 84-97, Geological Survey of Japan.
- Oyama, T, and Ushijima, N, (1990). "Japanese R&D Program of the Manganese Nodule Mining System," *Proc 4th Pacific Congr Marine Sci & Tech*, Vol.1-
- Tomishima, Y et al. (1989). "Physical and Engineering Properties and Basic Consideration of Mining Machinery of Massive Submarine Polymetallic Sulfide," *Rep 5th Symp Deep-sea Res Using Submersible "SHINKAI 2000" Sys*, JAMSTEC, Yokosuka, pp 283-290 (in Japanese).
- Tsurusaki, K, Itoh, F, and Yamazaki, T (1984). "Development of In-Situ Measuring Apparatus of Geotechnical Elements of Sea Floor," *Proc. 16th Offshore Tech Conf.*, Paper No 4681.
- Tsurusaki, K, Yamazaki, T, and Handa, K (1994). "Geotechnical Properties of Deep-Sea Sediments and Manganese Nodules in the Penrhyn Basin, South Pacific (GH83-3) Area," in Usui, A ed, *Marine Geology, Geophysics, and Manganese Nodule Deposits in the Penrhyn Basin, South Pacific August- October 1983 (Hakurei-maru Cruise GH83-3)*, pp 225-240, Geological Survey of Japan.
- Yamazaki, T, Tsurusaki, K, and Handa, K (1989). "Experimental Study off Adhesion Appearing between Plate and Clay," *Proc 8th Offshore Mechanics and Arctic Eng Conf.*, The Hague, Vol.1, pp 573-579.
- Yamazaki, T, Tsurusaki, K, and Handa, K (1991). "Discharge from Manganese Nodule Mining System," *Proc 1st Int Offshore and Polar Eng Conf.*, Edinburgh, Vol.1, pp 440-446.
- Yamazaki, T et al. (1993). "Geotechnical Comparison Between Deep-Sea and Seamount Sediments," *Proc 3rd Int Offshore and Polar Eng Conf.*, Singapore, Vol.1, pp 137-141.
- Yamazaki, T, Chung, J S, and Tsurusaki, K (1995a). "Geotechnical Parameters and Distribution Characteristics of the Cobalt-Rich Manganese Crust for the Miner Design," *Int J Offshore and Polar Eng*; Vol 5, No 1, pp 75-79.
- Yamazaki, T. et al. (1995b). "Geotechnical Properties of Deep Ocean Sediment Layer," *J. Mining and Materials Processing Inst. Japan*, Vol. 111, pp 309-315 (in Japanese)
- Yamazaki, T., Tsurusaki, K, and Inagaki, T. (1995c). "Dynamic Response of Deep-Sea Sediments to the Collector Touch-Down," *Proc 5<sup>th</sup> Int Offshore and Polar Eng Conf*, The Hague, Vol. 1, pp 315-320.
- Yamazaki, T., Tsurusaki, K, and Chung, J.S (1996d). "Geotechnical Properties of the Pacific Seamount Sediments Measured by a Gravity Corer," *Marine Georesources and Geotech*, Vol 14, pp. 3-17.

## Summary of the Presentation and Discussions on a Fundamental Study For the Development of a Collector Sub-System and its Future Technological Needs

In Mr. Tsurusaki's oral presentation he indicated that he was greatly honoured to present his paper entitled "A Fundamental Study for Development of a Collector Sub-system and its Future Needs in Technology". He worked with the Japan Environmental Management Association for Industry, he said, and would first talk about the geotechnical properties of deep-sea sediment, and engineering and distribution characteristics of nodules. Then he would talk about the relationship between geotechnical properties and collector performance including collector manoeuvrability and the collection mechanism. After that he would talk briefly about the Japanese-developed collector system and its deep-sea test to be presented in detail later by Dr. Yamazaki. Last, he would talk about breakthroughs needed for future collector development

*Mr. Tsurusaki* reviewed the development of nodule collector subsystems. Their performance and design is strongly affected by the geotechnical properties of the sediments and of the nodules, both of which he reviewed in detail. These relationships were discussed with reference to the Japanese collector development and the deep seabed mining test conducted in 1997. Two cases were examined specifically for their towed sledge hydraulic collector. One was for the towing action that included the resistant forces caused by frictional drag, the rejection of molded sediment in front of the collector, and the adhesive qualities of the sediment. The other was for the very sensitive moment of touch down of the collector on the seabed. A new method was developed to measure the modulus of elasticity and the viscosity of the sediments. The collector test, which was described later by Mr Yamazaki was carried out on a seamount at a depth of 2200 m. The nodule density was 15.6 kg/m<sup>2</sup> distributed on thin foraminiferous sediments much different from the deep seabed sediments. The test was successfully conducted, however, over a towed distance of 535 m with a pickup efficiency estimated at 87%. The importance of collector efficiency to a successful mining operation was stressed. There are two ways to improve this, he asserted, to increase sweep efficiency and to reduce downtime. Future collector development should include a self-propelled mechanism with obstacle avoidance, extreme reliability of components and instruments, to obviate the need for retrieval of the collector, and a control buffer between the collector and the vertical lift.

Comments addressed mainly the comparisons between geotechnical measurements for sediment properties taken on board the vessel and measurements taken on the seabed. Other questions related to the differences between the original and re-molded vane shear strength measurements, and as an environmental issue, the measurement of noise introduced by the operations.

### Testing On-Board versus *In Situ*

Mr. Tsurusaki indicated that they had not compared the on-board measurements. They had built an *in situ* measuring device but had not yet been able to test it satisfactorily after modifications. He indicated that the French had carried out such measurements from a submersible. Another participant said that they had found no difference between the measurement *in situ* and the measurement made later on the cores. The measurements were not exactly at the same point but were in the same area. The strengths were less for the *in situ* measurements and this may have been due to disturbance of the core during its passage to the vessel. There is a liquid surface layer in the first five cm that is missed most of the time in the core samples and that gives a weaker result when measured *in situ*. That is not so important for the design of a large collector, Mr. Tsurusaki said, but for other purposes it is very important. To measure that they had used a very sensitive coring apparatus that was sealed top and bottom so that the bottom water did not mix with the liquid layer.

Other participants affirmed that confidence can be taken in shear measurements made on the cores, and that there is no important difference between them and the *in situ* measurement. Others had compared such measurements taken on the Chinese site and had found differences but less than reported here. They also believed the reason to be the disturbance of the samples. The difference in the test results was between 20% or 28% with the shear strength a little bit higher in the measurement on board ship. Sampling at the Korean site with multiple cores showed water content of the top 5 cm about double the 4 cm value, which is very weak. The shear strength of that sediment could not be measured. Such a liquid layer on the bottom was not really seen from the French submersible and it was suggested that the sediment layer may be very inconsistent and lie on the bottom in some quantity covered by a clean water layer so that there is a kind of moving interface to which attention must be paid.

Even taking many precautions in getting to the core, there is some mixing between the water at the top and the first layer of sediment during the return. On the bottom that mixing may not happen. That is not so important for a vehicle on the bottom because it will probably not interfere too much. What is much more important is the first 5-10 cm that the system will enter, whether it is a crawler or a ski.

This phenomenon seems to be more consistent than the core measurements would suggest and needs to be examined in more detail. Comparisons of box cores with other cores at the Korean site showed a few cm of radius lost with the box core.

### **Original versus Disturbed Shear Strength**

A question referred to the definition of original vane shear strength measurement and re-molded vane shear strength measurements. For the on-board measurements a vane shear meter was inserted to 10 cm and measured as the original, the meter was then turned several times in place and measured again to give the re-molded or disturbed vane shear strength.

### **Noise pollution**

Responding to another question, Mr. Tsurusaki indicated that they had not conducted any experiments on noise pollution in the sea from the collector but had heard that morning that noise was used as an instrument to measure the amount of nodules collected during deep sea testing. He believed the greatest noise is from self-propelled motors on the collecting mechanism and from the lift-pump, things like that. Other participants reported having data on the noise of the free diving pump or hydraulic equipment and had also measured them in tank tests on land. On the survey ship there were many noises so the hydrophones were towed a long way off. Mr. Tsurusaki suggested that new technologies for acoustic measurements in a noisy environment are needed.



## Chapter 5

### UNDERSEA PLATFORMS/VEHICLES

#### The IKS – Crawler

*Professor, Dr. Ing. W. Schwarz  
Institute for Construction  
University of Siegen, Germany*

#### **Introduction – Ground Vehicles**

#### **Environmental Conditions**

#### **Summary**



## **INTRODUCTION - Ground Vehicles**

Undersea vehicles cover all vehicles which move under the surface of the water. To this group of vehicles belong towed vehicles, which are dragged by ships in the sea. Towed vehicles can also be controlled by hydrowings and herewith active movements are possible in all degrees of freedom. Towed vehicles have no contact with the sea floor and only move in the water. One variant of this kind of towed vehicle are vehicles with their own engine, they are submersibles.

As carrier vehicles for manganese nodule mining machines, vehicles moving on the sea floor are chosen, which are accurately moved parallel to the surface of the ground. They may be passive chassis vehicles without engines (dredges or sledges), or self-propelled machines.

Apart from certainly interesting inventions, only track vehicles are favoured by today's knowledge. There was once a very interesting development with two counter-rotating Archimedean screws (to be seen in Toulouse). This development was, however, suspended. On the basis of today's knowledge, mainly crawlers are regarded as self-propelled deep sea vehicles moving on the soil.

### **Crawler-type Ground Vehicles**

Crawler-type vehicles are preferred for very soft ground soils such as moor ground, rice fields and so on. The most important property is based on its manoeuvrability on soft grounds. The ground contact area is very big and that means that the soil pressure under the contact area is very low. For this reason, the trafficability on soft grounds is generally possible.

#### **Video clip "IKS-Crawler" ('92)**

For self-propelled machines in the sense of mining machines, track assemblies are favoured for application on the soil of the deep sea. IKS started the development of deep sea crawlers/components in '82.

#### **Soil Mechanics (Design Restrictions)**

Because the soil strength and bearing capacity of the deep sea soil vary significantly strongly from place to place, and because there are areas which are completely unsuitable for the passage of crawlers, a limit of trafficability had to be defined. Hereafter the design data for the development of the crawler could be determined

Measurements of the soil mechanics properties are available from the C/C-breakzone in the Pacific Ocean and from the central Indian Ocean.

Below an extremely soft (semi-liquid) upper layer of sediment (5 to 10 cm thick) there is cohesive soil. Its strength might grow slightly with depth. The water content of the soil is around 1.8 and the consistency factor according to the Attenberg scale is below 0.2, the internal friction angle can be approximated to "0".

In the IKS, followed by NIOT, trafficability is defined as follows:

Deep sea soil is trafficable if the shear strength of the soil is not lower than 2.5 kPa (measured with a vane tester according to DIN 4096).

The static soil-bearing capacity is calculated according to the Rankine-Terzaghi fundamental theory. For soil with no inner friction the bearing capacity of the ground beneath the semi-liquid layer is calculated for different penetration depths at the limit of trafficability:

12.85 kPa without penetration  
14.51 kPa for 10 cm penetration depth  
16.17 kPa for 20 cm penetration depth

The influence of the shape and size of the contact area is quite low and the influence of the contact pressure is quite low, too.

With consideration of a safety factor, the contact area of the crawler belt on the soil can thus be determined for the total weight of the mining machine in water. Here it is presupposed that the contact pressure of the soil is evenly distributed under the contact area.

The relation between contact pressure and shear strength is so small that it can be neglected for the limit of trafficability of the soil. Therefore the maximum tractive force of the crawler depends only on the soil contact area of the crawler, the soil-shearing strength and the soil deformation. The soil deformation is a consequence of slippage of the crawler. That is the backward velocity of the trackbelt of the crawler on the soil. In the ideal case, the trackbelt rests on the soil with its contact area without movement. In this case the slippage is equal to zero. The displacement, caused by the slip of the soil is zero at the front of the contact area and rises linearly to the rear end.

With consideration of soil deformation, the tractive force can be calculated for each traction tooth section.

The sum comes to the traction force of the trackbelt, which decreases with increasing slippage. In case of very soft deep sea soils with low shear strength maximum in relation to the residual shear strength, the influence of the slippage on the resulting tractive force is very small. In this case the middle traction shear stress tends to the residual shear strength.

Apart from a limited weight of the mining machine, the tractive forces are also limited by the given soil contact area. This has effects on the entire concept of the mining system, concerning dynamic resistances of the mining machine, drag loads and the slopes of the bottom, which the crawler has to overcome. Because the mentioned resistive forces are predominantly dependent on the driving speed, that must also be limited.

### Requirements/Features

Requirements for the design of the crawler can partly be derived from the environmental conditions (E) and from the task/mission the crawler has to fulfil (R) or can be features (F).

## ENVIRONMENTAL CONDITIONS

### Laboratory

A1	Surrounding medium: air	E
A2	Temperature: up to 50°C, relative humidity: 90%	E
A3	Morphology: plane	E
A4	Soil: tight, loose sand	E

### Deep sea

B1	Surrounding medium: sea water	E
B2	Water temperature	E
B3	Surrounding pressure: 1:1-600 bar	E
B4	Location: Central Indian Ocean: 75,06°E - 75,85°E, 13,36°S – 12,78°S	E
B5	Sea state for launching: max 5	E
B6	Bottom conditions mainly plane, partial hard obstacles at 150 cm steep height, ditches and hills	E
B7	Soil: shear strength between 0 and 7,36 kPa, with a semi-liquid coating	E

### Requirements/Features of the classics

C1	Total weight of the machine: in air 10 t, in water 8 t	R
C2	Total width: 3500 mm, axle distance: 3200 mm, gauge 2200 mm, contact area: 8, 32 m <sup>2</sup> R	R
C3	Average static soil pressure: $p^* = 11$ kPa	R
C4	Load distribution on soft soil and horizontal ground: front $1,1 \cdot p^*$ ; rear $0,9 \cdot p^*$ ; (location of gravity centre)	R
C5	4 – point support system (balancers for sprocket wheels and in-line boogies)	R
C6	One trackbelt at each side (right and left), two drive chains at each trackbelt	R
C7	Flexible ground pads (fibre enforced resin)	F
	Width: 1300 mm, length: 240 mm	
C8	Rear drive system and mechanical tensioning device: 2 sprockets at each drive (19 teeth)	R
C9	Crawler velocity 0 ..... $\pm 0,5$ m/s, collecting velocity: $\pm 0,5$ m/s, automatic slip control (ASC)	R
C10	Design drive power: 2 x 15 kW; max drive force at creep speed: 5 t each trackbelt	R
C11	Min effective drag force at the limit of trafficability: 5KN	

All requirements are met by the crawler conceptual design which is shown in the following figure.

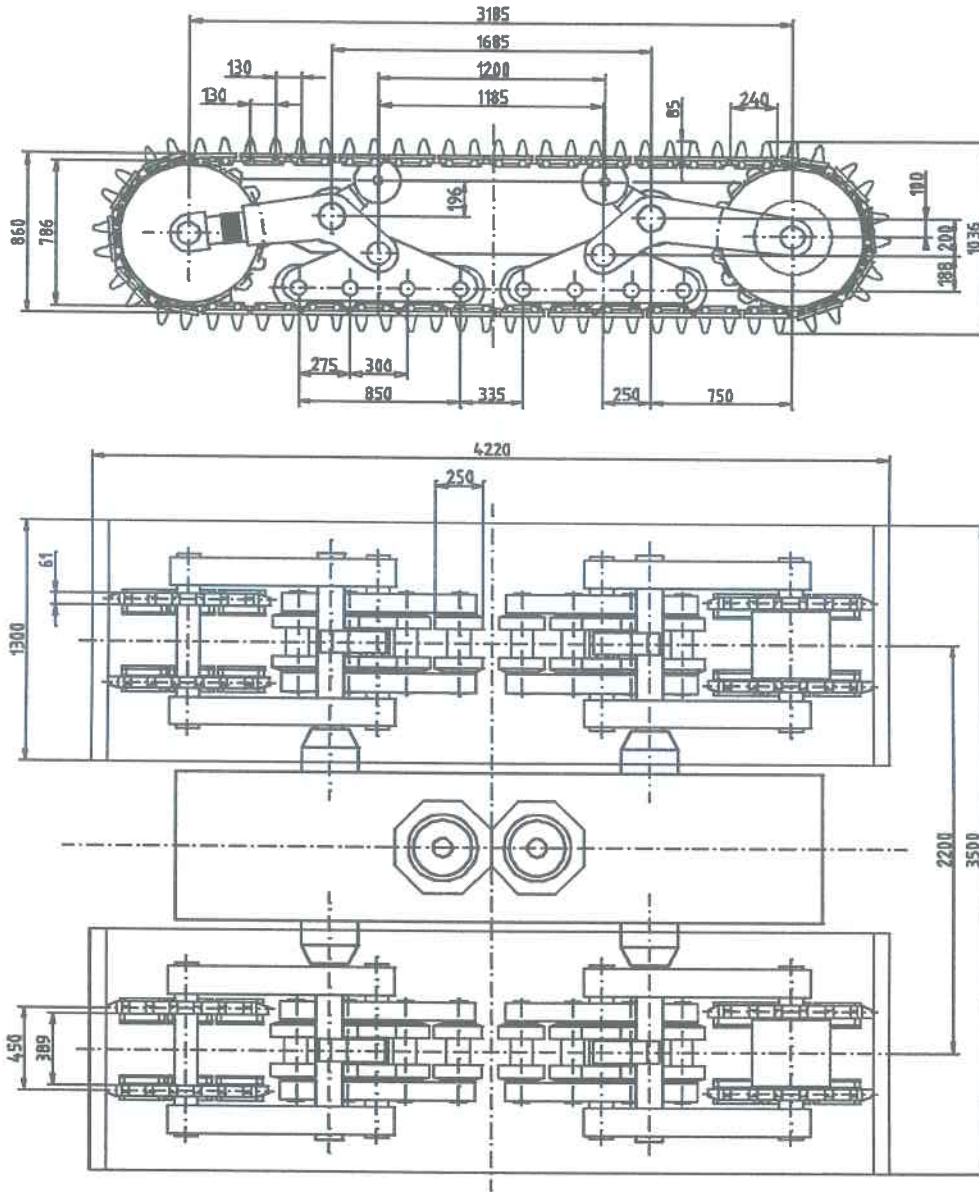

Crawler Chassis of the Deep Sea Mining machine

## Summary of the Presentation and Discussions on the IKS Crawler

*Professor Schwarz* outlined the basic requirements for ground impacting vehicles. He briefly described the various types appropriate for nodule mining including towed sleds, contra-rotating archimedean screws and tracked vehicles, the latter being, in his understanding, the only kind presently favoured for mining. Design restrictions imposed by the soil characteristics are significant and there are some areas completely unsuitable for the passage of crawlers according to DIN 4096. In most deep seabed areas below an extremely soft, semi liquid layer of about 5-10 cm thick, there is a cohesive soil. The soil is trafficable, by definition, if its shear strength is not lower than 2.5 kPA measured with a vane tester according to DIN 4096. The speaker described a crawler vehicle with toothed tracks designed for the Indian Ocean programme which is yet to be built and tested.

This presentation resulted in a great deal of discussion which went far beyond the specific content of the speaker's presentation, yet was very relevant to the purpose of the workshop. Technical questions addressed design of the tracks for the vehicle, the design of the umbilical, its reaction to environmental forces and supplemental mitigating design and control. Other queries related to the potential of a bottom sited, or submerged system to replace the topside vessels. Most of the discussion, however, centered on the transition from prospecting to exploration to exploitation and the effect of regulation on the operations to be carried out in each phase.

### **Belt track design**

The reason for the change from the original belt track design to the new chain design was queried. In response the speaker said there are only two possibilities to drive a belt: by a drum or by a sprocket and they chose the sprocket. The weight was reduced and there is no disadvantage in having a gap between the plates because the influence of the gap after a few cm is zero. All the area under contact will support the crawler.

The substantial difference between the shape of the teeth or cleats on the first versus the second belt was explained also. Initially the crawler was designed to move above the ground, so that the gaps between the teeth had the same volume

as the teeth itself and the belt would not touch the ground, and it worked that way. However with the semi-liquid over layer of the ground this was not satisfactory. The soil can go between the drum and the belt, giving additional problems. With the chain drive it is possible to squeeze out the semi-liquid soil and everything is open so it cleans itself better and saves weight. Also the friction contact between the drum and the rubber belt requires a strong drive force which is not necessary for the chain. So there is quite a difference but both methods are used in practise.

### **Selection of options**

A question was asked regarding the examination of existing options for which the design was already off-the-shelf. Professor Schwarz indicated that they had started with the design work for the first crawler in 1982 but now they have seen all the world literature on crawlers and are very fast at this work so it is easier now. A lot has been done and many hard-working students do this design work for their theses at no cost. He felt the new design was a very good one.

### **The umbilical**

A participant remarked that with just one straight umbilical to the crawler, it must be assumed that when it is lowered, the crawler sits just beneath the ship, to which the speaker agreed. In that case, he asked what happens when the ship moves a little bit and the crawler moves off? It will have to pull the whole umbilical with it because you do not have any propulsive force to let the major part of the umbilical follow. Professor Schwarz responded that there is an upper suspension of the umbilical at the ship and around which it can move up to 1km. The absence of a catenary in the cable was questioned because when the crawler is just sitting, the ship with the umbilical attached is moving at 15 cm per second. It must make a catenary, and the two speeds must be synchronized unless you move one part at a time. Tensions are limited by the catenary which must, somehow, be controlled either by the ship or by the crawler.

Professor Schwarz explained that the catenary could not be applied at first because during touch-down all vehicle movements were being measured and there was a risk to the vehicle. There are approximately 100 sensors on board so before touchdown they would know the exact height and speed of the crawler over the ground. They could measure it at a height of only 2 or 3 m and find out if touchdown should take place. Probably it is right to maintain a slow speed with the ship and the crawler to resist swinging, Professor Schwarz noted. The control at very low speed is a very difficult task and touchdown is very risky. On one touchdown the crawler toppled over and the cable had to be cut.

A further comment was made that with 5km of cable or umbilical down, the only way to run the crawler without causing it to fall on its side is to run in the same direction as the hanging cable system. The moment a turn sideways is made there will be a sideways pull. Professor Schwarz answered that the catenary would follow. The line is nearly vertical because there are floats and at the bend there is a three-dimensional shape, that is very clear. The resistance of the umbilical in this mode has been calculated and is not very great.

### **The effect of currents**

Further questioning of the induced stresses brought up the issue of subsurface currents that Professor Schwarz indicated might be a problem if they were not constant. In the case of a 15 cm per second current, that is not uncommon even in Central Ocean regions, that is pulling one way and the crawler trying to move the other way, it would be necessary to reduce the axial radius to the load under the suspension. The crawler has to run in the same or the opposite direction as the main resulting current. Current changes must be expected and on the bottom submarine storms and suspended sediment flows can cause unexpected changes. Professor Schwarz indicated that they had not prepared for all these situations but would deal with them as they occurred. He did not expect such problems to be common and would look forward to gaining experience in this matter.

### **Application of a dead-weight**

On the suggestion of employing a dead-weight with drive motors at the end of the umbilical like the ODP drill ship, with a flexible umbilical to the crawler, Professor Schwarz indicated that he understood the solution but was not in favour of it. He thought it better to gather the field experience first, as they had done with their tests at 500 m, and these had not been so bad. They would be testing the existing system in late 1999 and he hoped that the new design would be ready for testing in about three years.

In the experience of one participant, their deep ROVs, at 6000m needed a dead weight of 1.5 tonnes on the bottom of a 20 mm diameter cable. This was followed by a 300 m catenary to the ROV which was not easy to manage. The participant suggested a dead weight of probably several tonnes with the flexible hose because, when the ship is in motion, it is better to have the line neither straight nor in a catenary, because it would be very difficult to manage. Professor Schwarz responded that it may be necessary to anchor the umbilical at the ground and have another catenary but they needed to get experience and had only a few examples to refer to at this time. Because of the difficulties they would at first try to avoid the situation, he said, but as an engineer he was very optimistic that they could solve the problem.



## **Clogging of the pipe**

Professor Schwarz was asked if, in the case of sudden break-down the contents of the flexible hose would fall to the bottom and clog the pipe. He replied affirmatively that if they open the connection between the hose and the pump the nodules would fall down. He indicated that it would not be a problem because when they do not fall out they do not come down. It was suggested in that case that a buffer system would be very effective in controlling down time as well as the feeding of the nodules into the riser.

## **Ground speed control**

Someone asked if there were sensors to measure the ground speed which was needed for the active automatic slip control to control sliding of the vehicle. He was informed that there were acoustic systems to measure it in both x and y directions, along the path of the machine and laterally.

## **Future bottom systems**

Would it be possible some time in the future, it was asked, to replace the surface vessel with a large submersible and load the nodules on the seabed to take them wherever they are to be taken? In answer to that question, which he liked, Professor Schwarz said he thought the best way to protect the environment would be to take each nodule by hand. That would be the cleanest method but he did not think it would be economic. Technically, a lot of things are possible and new ideas seem often very easy, but he feared they could not always be managed in an economical way. Nevertheless it was worth thinking about. Others thought that it would be a lot cheaper, and would reduce the risk and the cost. An example seen in Japan once, was some research on an underwater city. Perhaps it would be possible to have some kind of submerged box or platform in the nature of a habitat. It might be more stable to operate from something that is suspended in the ocean rather than on the surface of the ocean. Of course it would still need power and other things from the surface. One participant agreed that they had such an idea about a submersible city, but had not done any R&D. It was just an idea.

## **Implications for the Mining Code**

A question was asked that related to the implications for the Mining Code that was in the process of being discussed by the Council at the political level. The work that Professor Schwarz presented was showing what might be understood by the Council as pilot test mining. Everybody on the Council, it was suggested, had different ideas about the technology and they may think that the system described

may have already been tested. Professor Schwarz pointed out that it was a small-scale system but the participant who was a member of the Legal and Technical Commission, stressed that it was being tested under the code that was presently being discussed and would come under those regulations. During the following week when the Council would start talking about it they would need some real information, he said. How long would these tests be? What quantity of nodules would likely be recovered? This could be an opportunity to present some real numbers so when the Council did talk they would not be speculating about inappropriate facts and figures. It was reported that in three years time this system would be launched for engineering tests to establish whether it will work and to get an idea of its application. How long will the test be expected to last? Professor Schwarz had indicated a production capacity of 25,000 tonnes a year but said that because he was only a partner in the work the questions should be asked of the Indian partners who included NIOT, (Indian National Institute of Ocean Technology), and the DOD (Department of Ocean Development) of the Government of India. NKS were the machine designers and brought technical know-how from former times to the work. The political part should be discussed with India.

As a theoretical and technical question, he was asked that if it were left to him to test this system at 5000 m depth of water, how long would he, as an engineer, want to run it and how many tonnes would he want to extract to feel confident that the system worked? Professor Schwarz replied that for their guarantees they would probably need only a few days. The specified guaranteed capacity was 8 tonnes per hour but it was designed to handle up to 20 tonnes, though this amount may be rare in one hour. The Indian partners were looking at a test capacity of 25,000 tonnes because they wanted to get some experience of capability and viability so some time would be needed for the operation. If a machine only sometimes works it is not good and it was agreed that time is required to gain experience so the test should probably run for approximately three months. That was only an estimate and was not guaranteed; other numbers would be developed in the future.

Under an agreement with the Indian Institute there were to be two phases. Phase 1, would be sand mining at a depth of 500 m in Indian waters, to end in December 1999, and Phase 2, design work for which the requirements were written but funds were not available at the time of discussion.

Another experienced operator indicated that most operations at sea for exploration, or mining tests of this sort would be limited between 30 and 45 days because of the capacity of the ship and the fact that people want to get back to land now and again. Any kind of testing programme is probably going to be in segments, he said. If you take a system out and test it for the first 30 days and you find some problems with it you are very likely to take it back to

land, make modifications and improvements, maybe change crew, maybe not and take it back out and do it again. So it may be spread out over a period of six months or even a year but in terms of actual time at sea, testing the machine on the seabed, it will not be extensive.

For example, in 1976 INCO and OMI went out for the sole purpose of testing collectors. There were eight different machines to test. They were there for one 30-day cruise and partially into a second 30-day cruise when a problem caused them to cancel the rest of the programme and come back although they had only intended to be out that one 60-day period.

The initial commentor explained that the reason for his question was that there was no Code for Mining in place. The Council had tried to put a code for exploration and prospecting in place without any real numbers and these are the kinds of issues that have been raised by different council members who do not understand the situation. Some kind of better information and ball-park numbers would be needed. These tests would be done in the Central Indian Ocean at the Indian mining site and so perhaps the Indian Government would give this information.

Some additional and corroborative information was presented by another participant about a British made crawler that was used in the Bering Sea in Alaska in 1989 in 70 feet of water. The same problems of current direction, and forces acting with change of current, were evident on a daily basis on the pipe line. The testing period initially was three months and it had to be extended to four months, not to prove that the crawler worked but to find out what had to be done to it in the next season to hopefully make it work the following year.

De Beers Marine, when they launched their first crawler off south western Africa in 1989, went to sea for a period of three to four weeks. During that time the crawler was on the seabed for maybe only 100 or 200 hours, spending most of the time on the deck being repaired, or modified. It was two years before it finally began production. Another company with a modified crawler never got into full production until four years after it was first launched; so the pattern is, you go to sea, you test, you find out what you have done wrong, you try and correct, you go to sea again, find out what else is wrong, come back again and maybe two, three, four years later you have got yourself an operating unit. That is the way it happens. This was verified by another participant who agreed that they had done the same. Three years was their minimum time but the maximum time was six years.

The Indian Environmental Assessment Programme was described by a participant as having a mining test scheduled from 2001-2003 in an area among five

small sites previously selected for such kinds of tests. One of the five had been selected for the Benthic Impact Experiment (BIE) and they still had one or two sites for the mining systems tests. The location was known and the nodule abundance in the area for mining test was 7 - 8 kg/square meter. Professor Schwarz agreed that was the average of values from 5 - 10 kg/square and that it was planned to go to that site in the year 2000 to test the soil strength *in situ* but no nodules would be collected.

### **Pilot mining tests**

It was suggested that beyond the basic collector tests, going to a pilot or a scaled mining test is really testing the whole system, not just the collector at the end. If the collector fails it would probably not be possible to test any other component of the system realistically. So back to this "keep it simple" idea. It was recommended to anyone going out there on a pilot scale level to test an entire system, that they use some relatively simple collector or have a back-up system for the collector.

Several comments had just been made about crawler machines, which indicated they were complex machines taking years to develop and years getting them into production. The OMI story goes back now 20 years but OMI went out with a collector tests on a 30-day test programme and had functioning collectors that very first time because they were so simple. Two years later they went directly from that one programme at sea, testing collectors on the end of a cable, to a pilot mining programme. There were lots of problems along the way but they still got 800 tonnes of material on the deck of the ship. They may not have been able to do that had they been trying to test self-propelled machines. That is not to say, do not try to test them, or that they are not worthwhile in the commercial sense, they probably are, but it would be useful during the tests to take a basic, very simple machine out there as backup in case the more complicated one fails. The ability to test the rest of the system would be retained, even if it was at some reduced capacity from that anticipated with the primary system.

### **Sampling versus mining**

The comment was made that if some one had said 800 tonnes during the discussion in Council there would have been great concern that it was more weight than a sample should be. In the development of the Code but without understanding what was being done, Council members might have said that was mining and therefore exceeding the rules they were trying to establish. This would indicate the importance of knowing what is involved in testing a system with some real numbers, otherwise there may be regulations imposed, or passed which are not practical. A lot of the modelling may be done on a computer and with real data collected during testing, that can be done but they have to be related to a real scale model.

On the same issue, it was asked why the ISA wants to define what is sampling and what is mining? In the diamond mining industry offshore Namibia, for example, it is not possible to distinguish the points of change from reconnaissance sampling to evaluation, to bulk sampling, to trial mining, to mining. Only after the event can these stages be distinguished because each is gradational. If the governments of Namibia and South Africa had set up definitions of “exploration”, “mining”, and “bulk sampling” within which the mining companies had to operate, the industry probably would not have even got off the ground.

Some one else remarked that in the deep seabed regulations in the phase of exploration and testing, the nodules collected should not be used for commercial purposes because it would initiate a new phase of operations. Money is being earned and so the regime of taxation and other levies would take effect. Another comment was made that it was not important that the amount of nodules collected should be only 100 tonnes or even 10,000 tonnes. If the system needs to be operated to collect 10,000 tonnes for [metallurgical] testing the Authority should authorize that provided it does not give profits to the contractors. The expenses would be much more than any revenue from the metals extracted during the treatment test.

The original commenter said he was not trying to put a maximum figure on what was acceptable, just some information on what actually happens in real life. A figure like 800 tonnes, would probably cause a lawyer to raise his eyebrows and these are the types of people who would be there. It is true that the issue of making money from the testing must be kept flexible, but the key criterion is that the test production is not being used for commercial purposes.

### **Existing regulations elsewhere**

Another comment related to regulations for offshore mining in the United States EEZ, that allow for testing in the middle of the development sequence that runs from prospecting, to exploration, to testing and then to mining. When going to commercial mining there are royalties levied on the production. The initial testing, including bulk sampling, was classed as exploration on which there are no levies nor was there a limit to the tonnage that could be mined. These things can best be assessed on a case by case basis.

A previous commenter spoke on what happened in practice in Alaska and southern Africa, where there was no limitation on when exploration developed into trial mining. It was very important for the producers, in the case of gold, and now of diamonds, that they could take bulk samples as opposed to just single point evaluation samples because, in fact, the value of the samples could represent over 50% of exploration costs. That is how a private company finances a lot of the work.

In the case of Alaska the difference would come on moving to a formal declaration of production mining, and that is when all the environmental mitigation processes had to be put into effect. During test mining there was not an official requirement to do that, though it was done in practice because the company felt they were being good citizens in so doing. Only on a guaranteed day when it was stated that at 7am the company is going to production did the entire monitoring process have to commence. That is where the difference came in but taxes were paid [under totally different laws of the U.S. Internal Revenue Service] on all the gold recovered even from box sampling.

### **Impact of the new regulations**

There appeared to be concern that if this issue was not clarified and industry was not given the flexibility needed it would have the knees knocked out from it before it had even started. It was also suggested that, in principle, what was being attempted was sound but the organization establishing the rules did not have a lot of the technical details associated with the programme. The agency needed input to make sure, if nothing else, that things would not get put in the document that would be totally inappropriate. It was felt that they were not getting the input from industry or from wherever, and, in a sense were flying blind. It was pointed out that there were people in the present group who were involved but from the comment on the 800 tonnes it was clear that there had not been enough input yet.

In this respect it was noted, in summary, that one of the difficulties is to determine the cut-off point, say from exploration into exploitation, when royalties begin to be paid? It is just like saying what is the cut-off between prospecting and exploration. Also in real life while part of the area is being exploited other parts are being explored and the issue really is how to set up a system that will not be abused. It is easy to monitor in a one government, one nation set up where the licensee can be observed and information can be obtained as to what is happening, how far they are going, and where the contractors have reached - a lot of real life data. In the case of seabed mining there is no system at the moment.

From the framework provided by the Convention it is apparent that the Authority is going into something very new; where there is not the experience or knowledge and work is still in the experimental stage; even in the case of those who are developing technology or researching the area. So the issue is dealing with a number of operators over whom there is really no control or oversight. It may seem like there is but there is not.

It has already been seen from the information received from pioneer investors, some of which is a very peripheral description of what they have been

doing but nothing in terms of data or information that can really be analyzed to confirm the stage they have reached. In this case, when does the charging of royalties begin?

The organization has looked at the various mining laws for land, and there are cases where, in fact, the rules are based on legal challenges. Somebody mentioned this and looked at various possibilities, based on the level of production and the period for which that level is sustained. It can be said that if the production is sustained at a certain level for a certain period of time it has reached the stage of actually beginning to exploit the resource, rather than just testing equipment.

This is the issue to be dealt with in the next phase of the mining code that deals with the exploitation phase. There has already been some research as to how this has been done in other circumstances. In the case of land-based operations the process is much more realistic, in the sense of going through these stages. The Authority is supposed to monitor the developments but really much depends on what information the operator gives. There is no possibility of going to sea to observe, on every occasion, what is being done and there is no possibility to see what has been done with the nodules recovered. They are taken to land and may be processed or mixed with other sources of minerals or metals that would be very difficult to distinguish. These things can probably be done in the case of diamonds as well; but in the case of nodules there has to be some kind of benchmark beyond which the operation enters into the realm of exploitation. It is a difficult issue but it is something that has to be dealt with because there is revenue involved for the Authority and for mankind as a whole.

## Chapter 6

### DEEP SEABED MINING - UNDERSEA PLATFORMS

*Dr James R. McFarlane  
International Submarine Engineering Ltd  
Port Coquitlam, Canada*

**Knowledge**

**Brief Review**

**ROV Uses**

**Typical AUVs**

**The Next Phase**

**ARCS**

**Other AUVs**

**To Get to the Future**

#### KNOWLEDGE

*Knowledge of the Oceans is more than a matter of curiosity.*

*Our very survival may depend on it.*

- President John F. Kennedy

At the time a marine work system revolution was initiated which is still going on.

#### BRIEF REVIEW

We predict the future by considering the past and the present.



## 1960s

- Mixed gas diving
  - Hannas Keller
  - Captain George Bond, USN
  - Captain Cousteau
- Manned subs
  - StarI, DOWB, Beaver MKIV, Shelf Diver, Pisces
- US Navy CURV ROV was fielded.

## 1970s

- ROV moves ahead rapidly. The driving force is the offshore petroleum industry.
- Mid 70s, ROV development moves ahead rapidly: Frank Busby referred to this as the "thundering Herd Syndrome". The driving force is the offshore petroleum industry.
- By the end of the 70s, some divers and manned subs were replaced by ROVs.

## 1980s

- Mid 80s, Autonomous Marine Vehicle development begins in earnest. Although the concept has been around for a while the PC revolution contributes to feasibility.

## ROV Uses

### Offshore Petroleum Industry

- Visual inspection
- CP Measurement
- Cleaning sand and mud
- Anode installation
- Debris Clearance
- Transponder change-out
- Jetting/brushing operation
- Stab-in of guidelines
- Wall thickness measurements
- Bolt torquing
- Cable cutting
- Testing hydraulic functions
- Guide post placement
- AX/VX ring change out

### Other Uses...

- Military
  - Mine countermeasures
  - Torpedo recovery
- Science
  - Critter observations
  - Rock coring
- Other
  - Tunnel inspection
  - Archaeology
  - Accident investigation/salvage
  - Telephone cable maintenance

## ROVs

- ROVs are used to:
  - Reduce risk to personnel
  - Extend bottom time from minutes to hours and days

# ARCS



## Principal Characteristics

- Length: 17 ft. to 22 ft. 3 in.
- Diameter: 27 inches (68.6cm)
- Displacement: 2430 to 3420 lbs.
- Speed:
  - Normal: 4 knots
  - Top: 5.5 knots
- Range at 4 knots:
  - 22.5 mi with 10 kWh NiCd Battery
  - 45 mi with 20 kWh NiCd Battery
  - 180 mi with 80 kWh AIO<sub>2</sub> Fuel Cell (Fuel Cell Technologies)
- Depth: 1000 feet (304.8m)
- Propulsion: 2.5 HP brushless DC motor

# THESEUS



## Principal Characteristics

- Length: 35 feet (10.7m)
- Diameter: 50 inches (127cm)
- Displacement: 19000 lbs (8600kg)

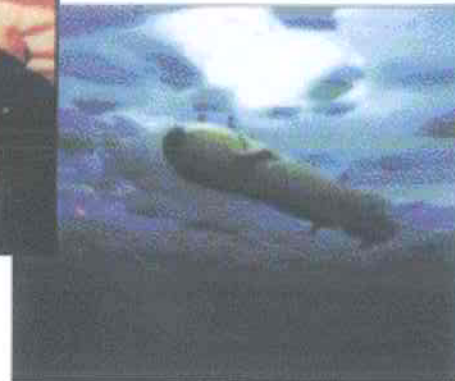

## ROVs

- Power: 10 HP
- Depth: 1000 meter



## ROVs

- Power: 25 HP
- Depth: 1000 meter



## Military - Trailblazer 25

Power: 25 HP

Depth: 500 meter



## ROVs

### MBARI - HYSUB 40 - 2000

- Vehicle Characteristics

- Height: 4.43 Ft.
- Width: 4.66 ft.
- Length: 8.23 ft.
- Weight: 5150 lbs



- Tool Sled Characteristics

- Height: 1.64 ft.
- Width: 4.66 ft.
- Length: 2.69 ft.



## Critters



## ROVs

### ROPOS - HYSUB 40 - 5000

- Vehicle Characteristics
  - Height: 65 inches
  - Width: 60 inches
  - Length: 100 inches
  - Weight: 5700 lbs



## Smokers



## Polymetallic Sulphides



## Polymetallic Sulphides cont.



## ROVs

- Power: 150 HP
- Depth: 2000 meter





## ROVs

- Power: 50 HP
- Depth: 2000 meter



## The Next Phase

- The next part of the Undersea System Revolution relates to the development of Autonomous Marine Vehicles.
- This is not a new idea.

## Nikola Tesla

Tesla's remote controlled, submersible boat, controlled by "coded pulses via Hertzian waves", which he demonstrated in 1898

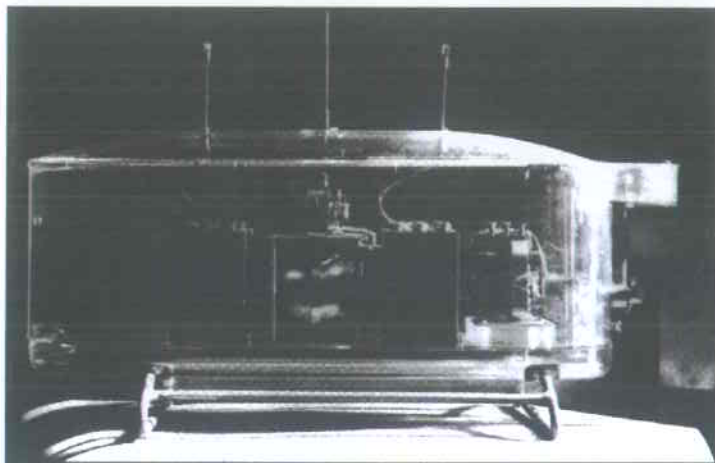

"They will be produced capable of acting as if possessed of their own intelligence and their advent will create a revolution."



## Typical AUVs

- Representative examples of small, medium and large sized Autonomous Marine Vehicles.

## AUV

An AUV is any autonomous platform capable of movement which goes in the water and carries a sensor.

*Larry Clark  
National Science Foundation, USA*

# DOLPHIN - Remote Minehunting System

- Principal Characteristics
  - Length: 28 feet (8.6m)
  - Diameter: 3.25 feet (.99m)
  - Mast Height: 15 feet (4.5m)
  - Displacement: 9850 lbs (4475 kg) fully fuelled
    - Can carry AQS 14 or other sidescan sonars
  - Propulsion: Caterpillar 3116TA 350 HP diesel



## Multi-Vehicle Operations



In the near future Autonomous Semi Submersibles will be programmed with standard tactical doctrine and rules of the road. The doctrine provides the foundation of an expert system.

## Other AUVs

- In addition to the AUVs described we can expect there will also be beer can and 48 oz. Juice can sized vehicles.

## AUVs (Animals)

- Seals, Sea Lions and other marine creatures are in many ways the perfect AUVs. They have engines which provide the same range as nuclear devices. They also know how to find other marine species. They are orders of magnitude smarter than cybernates.
- Some small GPS/Radio/Sensor packages have been fitted to animals and, in my view, the results have shown that animals are important and viable delivery platforms.
- The animal platform eats at the same trough we do so they will have to be used to generate part of the database.
- Animal delivered packages need more attention.

## Costs

- Vehicle costs should be measured not only in terms of first cost, but also life cycle cost. Energy use in the production of materials and energy consumption during operation is small. Vehicles also have trivial potential for pollution so low cost risk associated with pollution.

## Nodule Exploration Vehicle

Umbilical            25,000ft  
Water Depth        18,000ft

Two Body System

L = 22ft

H = 7ft

W = 6.5ft

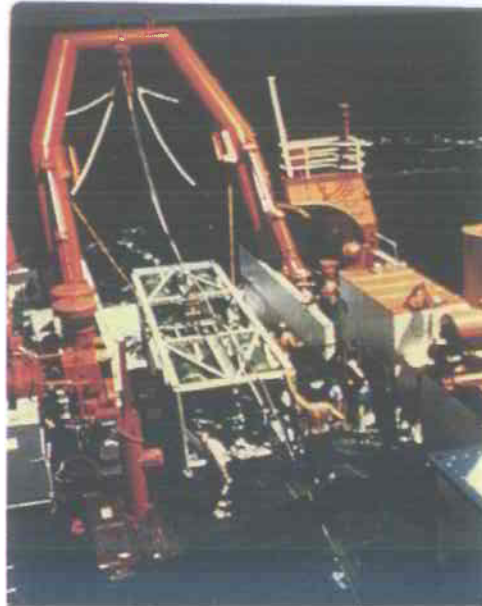

## Points to Think About

- There is no universal vehicle
- Attributes are mission driven
- No unique solution
- Sub set of the PC/Robotics revolution.
- We learn by doing

## To Get to the Future

- Engineering is incremental. Thus, in order for technology to continue to evolve, successive generations have to be produced. Even the PC has evolved through evolution. Thus, exercising one's capability is a *sine qua non* of development/evolution.
- It is unfortunate that we seem to have also used this process to evolve our capability for the production of paper. Now we have evolved to the point where we fielded more tons of paper than hardware.

## Limiting Factors

- I hold the view that we are currently not technology limited. That is not to say that we cannot benefit from additional technological advances. However, I believe we are limited because we do not exercise out integration skills enough. We don't spend enough time in the field. We are often imagination limited and will limited. We are also funding limited.
- We are amazingly casual to the point that it is hard to imagine that the survival of some life forms may depend upon our understanding of process.

# We Need Data to Get to the Future

- When sampling moves from remote sensing of the surface of the ocean to sampling below the surface, the number data points available per day changes by many orders of magnitude. The problem is how do we increase the sampling while keeping the cost down? AUVs used in conjunction with buoys and critters packing instruments can make a useful contribution. Idest heterogeneous systems.
- We need to define missions and then establish realistic sampling needs. We do not seem to use properly established criterion to define what is over sampling and what is under sampling. Sampling is an important issue which not only has a major effect on cost but also on the usefulness of the data.

## Sampling

Well then, can anyone tell me what this is?

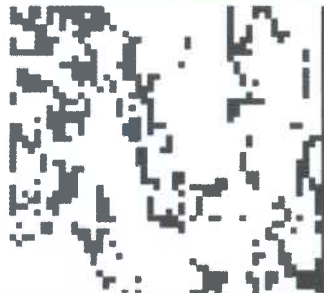

## Sampling



## Sampling

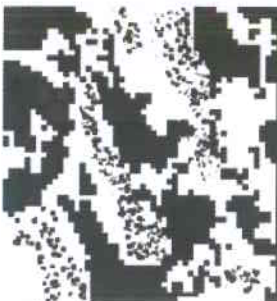

**NO**

Because it is also undersampled

## Sampling

- While these examples are amusing, we must remember that decisions are being made on this kind of information. It is even less amusing when we reflect that the decisions being made relate to our survival as well as the survival of other species.

## Sampling

For example: Predation pressure

- It is only through adequate sampling in accordance with sampling theory that we will understand the variables in this figure.

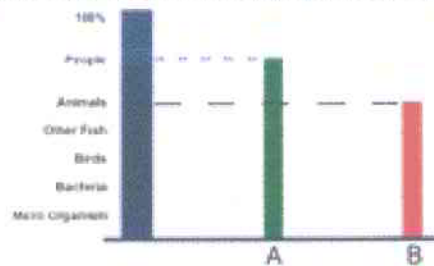

- If we are at "A" there is potential for turn around if we lower human predation.
- If stocks are at "B" convergence is "ZERO" if nothing is done to reduce non-human predation.
- At the moment, instead of establishing what sampling is required and marshal resources we are fighting over which animal or human gets to eat the "last fish".





## What About Law of the Sea, Article 76 and the Future?

- Look at the following examples of work which will have to be done.
- Who is going to develop the instruments to obtain the data to delimit our margins.
- Who is going to pay for the development and deployment of instrumentation to be able to sample.

## Law of the Sea

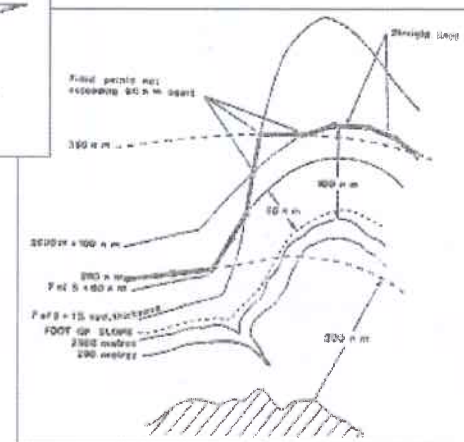
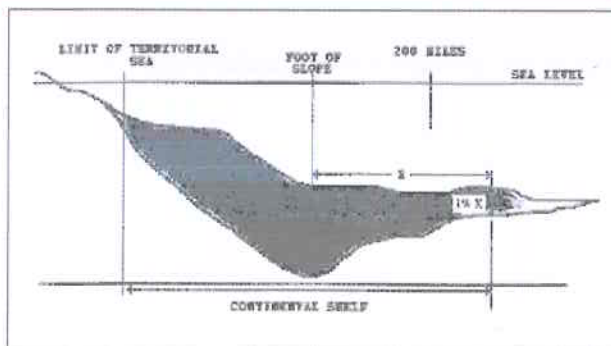

## Observations

- Technologies have been developed which will contribute to obtaining information at lower costs per pixel.
- More pixels are required if we are to be able to characterize process.
- Hardware development is incremental so we have to do things to evolve.
- We need to spend more time in the field.
- Technologies will have to be developed to deal with issues related to LOS 76: Who is going to pay for them?

## Going into the 21st Century

- You look at things and you say, why: but I dream of things that never were and say, why not." *George Bernard Shaw*
- For I dipt into the future, far as human eye could see, saw the vision of the world and the wonders that would be; *Alfred Lord Tennyson*





## Chapter 7

### DEEP SEABED MINING – LIFT SUB-SYSTEM

*Professor, Dr. Ing. W. Schwarz  
Institute for Construction  
University of Siegen, Germany*

#### **Hydro-transport Systems**

#### **Requirements for an Advanced Lifting System**

#### **Components of the Envisaged Lifting System**

#### **Design Data of a Lifting System for Pilot Mining Operation**

## Hydro-transport systems

In the 70s a multitude of lifting systems had been studied, and after that the hydraulic transportation of the manganese nodules to the ore barge had been favoured. That is still the state of the art.

After very expensive investigations there was a competition between the "Air Lift System" and the "pump system". Both of them had been tested *in situ* by OMI.

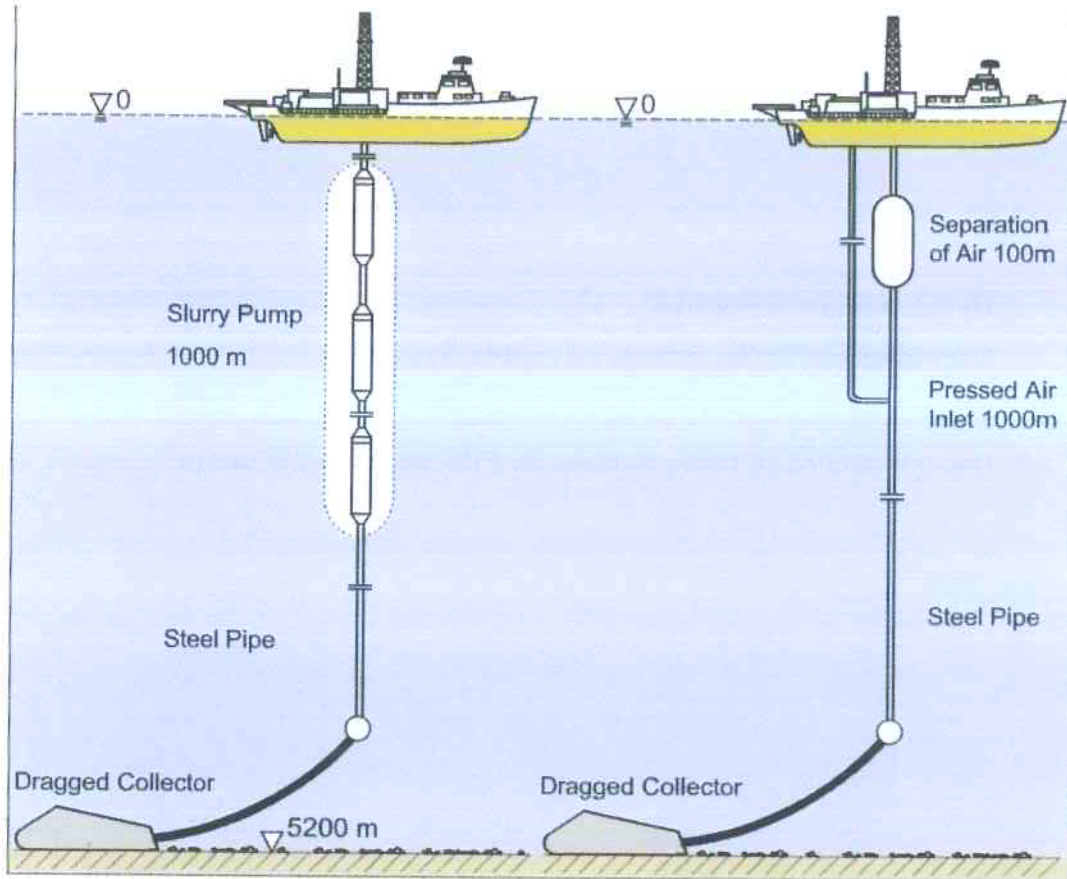

Figure 1- Pumplift / Airlift-system (OMI-Tests)

Both of the systems had worked fairly satisfactory, but the air lift method bears the disadvantage of higher energy consumption and the necessity of separation of the air after depression. The injection of pressed air was done in depth of app. 900 m and the separation of the air was done in a vessel at 100 m depth. In the riser underneath the air injection position prevailed under pressure. Therefore, there was a need of a rigid pipe riser, which is a handicap.

But some of the disadvantages of using centrifugal pumps had been recognised. For lifting manganese nodules from the seabed to the ore barge there are 2-3 centrifugal slurry pumps to be installed, and each of them has 12 pump wheels.

An alternative solution for the centrifugal slurry pump was found: That is a 2-stage ,clear-water pump in connection with a lockage to inject the nodules into the flow of clear water.

The most important advantage of this aggregate was the opportunity of positioning it on the mining machine. Therefore a fire hose type riser could be used, because the hydro lifting system had become a so-called high-pressure system with over pressure along the whole riser length. We wanted it to get rid of the rigid steel pipe riser, and all the drilling equipment on board of the mother ship.

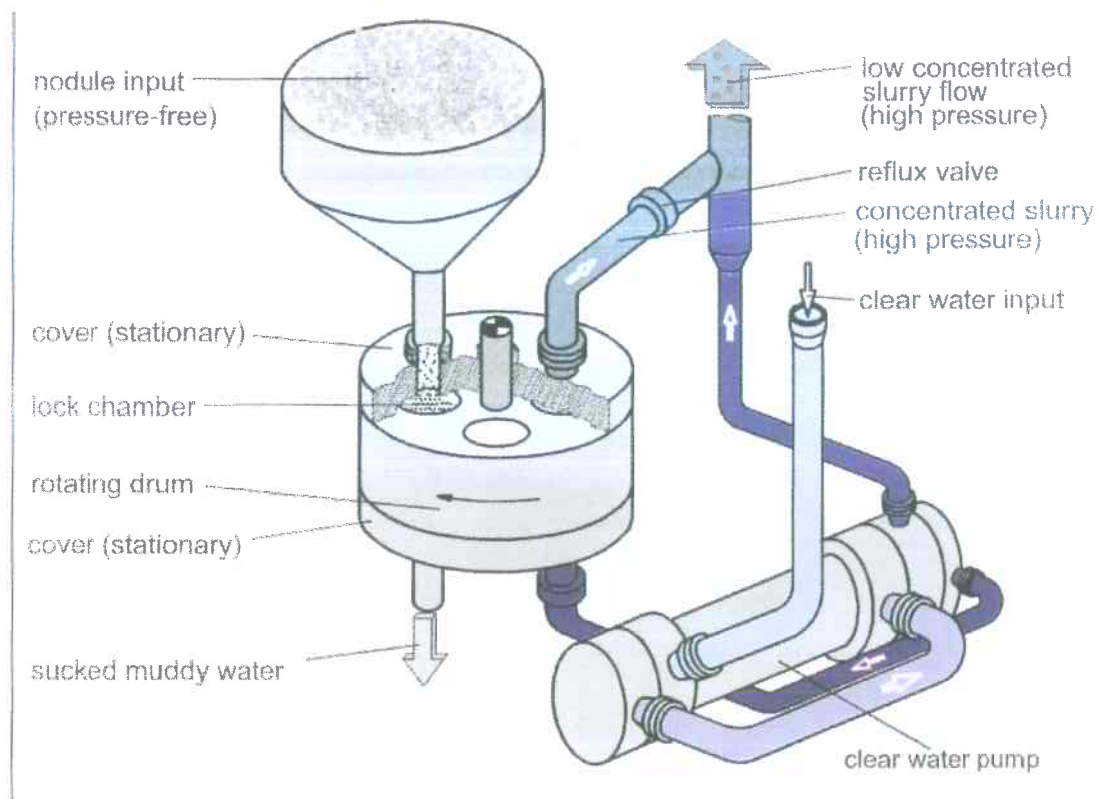

Figure 2 - Pump-Lockage System

Exactly this feature gives us the chance of turning away from the costly and dangerous oil drilling technology for nodule mining.

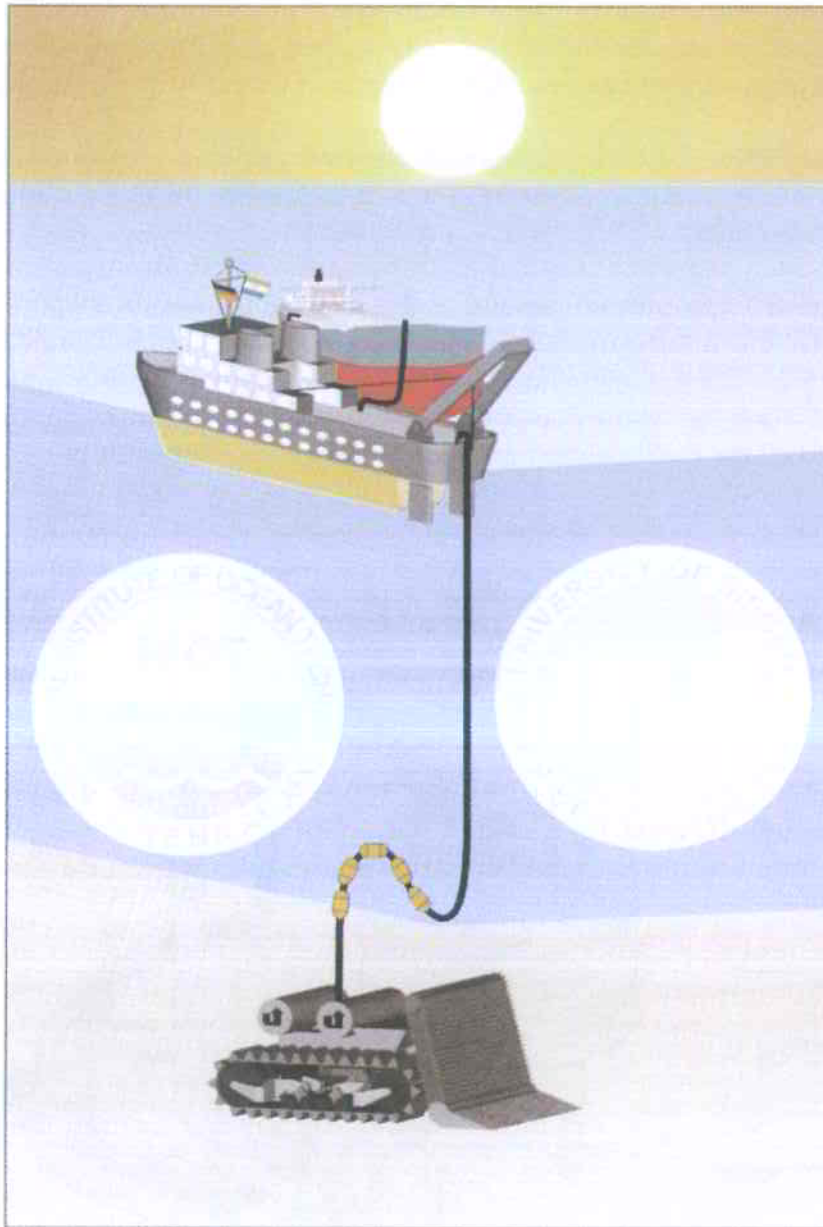

Figure 3 - Flexible Mining System

Efforts were made to develop that integrated pump/lockage - system, but the dimensions and weight of a piston type slurry pump seemed to be lower for a pilot mining unit - and in both of the cases we could not get rid of a certain pulsation of the flow.

The approach to the decision for the slurry pump in the pilot mining unit was also caused by the small diameter of the hose riser (85 mm), and consequently the nodules are to be crushed before pumping.

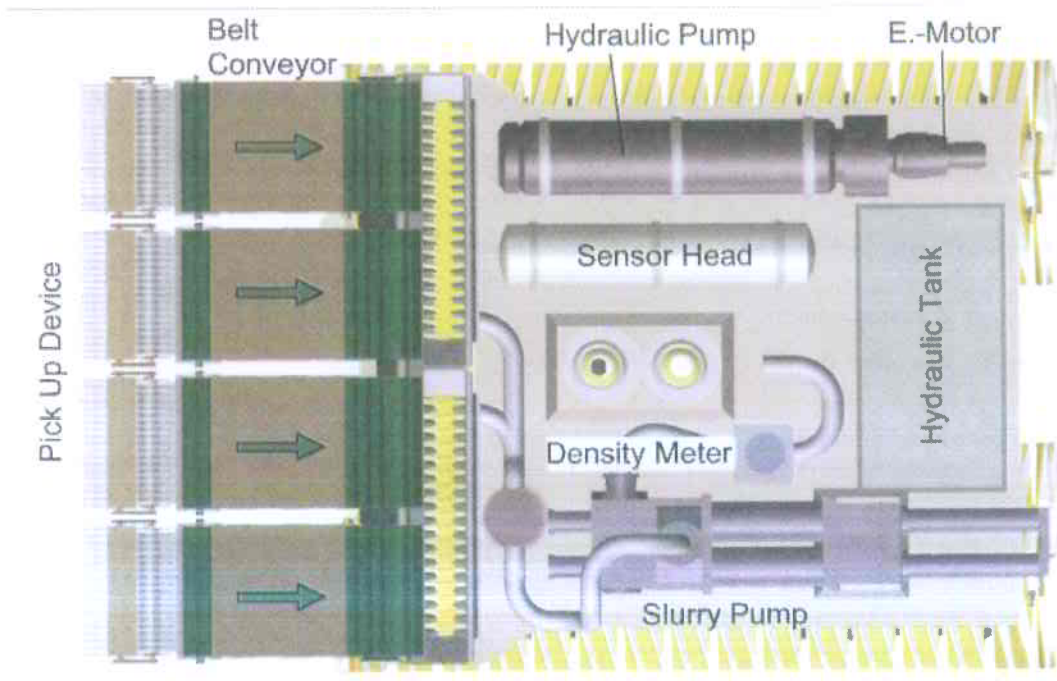

Figure 4 - Slurry Pump on Mining Machine (Top View)

## REQUIREMENTS FOR AN ADVANCED LIFTING SYSTEM

In front of an illustrated example of an advanced nodule mining system the following requirement for the lifting system had been written down.

### Flexible Riser

- Achievement of free movement of the mining machine in a certain motion area around the upper suspension of the riser.
- Limitation of horizontal forces at the mining machine by a catenary shape of the riser which is formed by floats
- Avoidance of kinks at the suspension on the mining machine by cardanic/spherical joint
- Use of the riser to support the mining machine during lifting operation in case of cable breaking



- Achieve independence of mother-ship/ore-barge from the riser in case of cyclone (floating platform)
- Evacuate the nodules from the riser in case of pump failure

### **Input Requirements**

- Feed only such nodules/fragments of 1/3 size of inner diameter of the riser
- Feed the riser with controlled slurry density
- Adjust the flow velocity to the grain size/sinking speed

### **Discharge of clouded Water**

- Screen off each particle exceeding 2 mm of size
- Discharge in water depth of more than 1000 m

These requirements could be reduced for the envisaged pilot mining tests, if the latter will be carried out during a cyclone-free period, but at the end we cannot renunciate them for a commercial nodule mining system.

## **IMPORTANT COMPONENTS OF THE ENVISAGED LIFTING SYSTEM**

### **Mining Machine**

- Nodule crusher
- Density-meter of the slurry
- Slurry pump
- Spherical/cardanic joint (hose suspension)
- Emergency discharge flap

### **Hose Lane**

- Hose & couplings
- Floats for forming the catenary shape of the hose

### **Water Surface**

- Floating station
- Floating hose to ore barge

## DESIGN DATA / LIFTING SYSTEM FOR PILOT MINING OPERATION

Solid mass flow (wet nodules)	8000 kg/h
Inner diameter of riser	85 mm
Lift height in water	6000 m
Length of the riser	7000 m
Density of wet nodules	2000 kg/m <sup>3</sup>
Grain size	≤30 mm
Shape factor of grain	0,7
Sink velocity of solids	≤ 0,47 m/s
Transport concentration	0,078
Spatial concentration	0,096
Mass flow of slurry	0,014 m <sup>3</sup> /s (51,12 m <sup>3</sup> /h)
Density of slurry	1078 kg/m <sup>3</sup>
Geodetical pressure	4,7 MPa
Dyn. Pressure loss	7,6 MPa
Total input pressure	12,3 MPa
Power consumption of the pump	174,9 kW





## Part II

### Presentations by the Registered Pioneer Investors

<b>Introduction</b>	162
<b>Chapter 8 The Japanese Experience in Deep Seabed Exploration</b> <i>Dr. Kazuo Shuto, Deep Ocean Resources Development Co. Ltd (DORD)</i>	167
<b>Chapter 9 An Environmentally Friendly Deep Seabed Mining System</b> <i>Mr. Feng Liu, China Ocean Mineral Resources R&amp;D Association (COMRA) &amp; Mr. Ning Yang, Changsha Research Institute of Mining and Metallurgy (CRIMM)</i>	187
<b>Chapter 10 Scientific and Technological Research and Development Related to Deep Seabed Mining</b> <i>Mr. Guy Herrouin, Centre de Toulon La Seyne, IFREMER</i>	213
<b>Chapter 11 Japan's Nodule Collector Test on a Seamount</b> <i>Dr. Tetsuo Yamazaki, National Institute for Resources and Environment (NIRE), Tsukuba, Japan</i>	245
<b>Chapter 12 Research and Development of Deep Seabed Mining Technologies for Polymetallic Nodules in Korea</b> <i>Dr. Sup Hong, Ocean Development System Research Center &amp; Mr. Ki Hyune Kim, Deep Sea Resources Research Center, Seoul, Korea</i>	261
<b>Chapter 13 An Overview of the Indian Polymetallic Nodule Programme</b> <i>Professor M. Ravindran, National Institute of Ocean Technology, Department of Ocean Development</i>	285

## Introduction to Presentations by the Registered Pioneer Investors

A unique aspect of the workshop was the almost complete participation of technical representatives of the pioneer investors. All seven registered pioneer investors were invited to the workshop and those present were representatives of COMRA, the China Ocean Minerals Research and Development Association of the People's Republic of China, representatives of DORD, Deep Ocean Resources Development Co. Ltd of the Government of Japan, a representative of IFREMER/AFERNOD of the Government of France, representatives of KORDI, the Korea Research and Development (R&D) Institute of the Government of the Republic of Korea and a representative of the Government of India. YUZMORGE-LOGIA of the Russian Federation and the Interoceanmetal Joint Organization (IOM) representing Bulgaria, Cuba, Czech Republic, Poland, Russian Federation, and Slovakia, unfortunately could not attend.

In relation to the specific work undertaken by the pioneer investors, both before and after registration, to develop technology for deep seabed polymetallic nodule mining, it may be useful to undertake a brief review of the activities that followed the re-discovery of nodules in 1958 among the annals of the 1873 Circum-Global Oceanographic Expedition of HMS Challenger, in the archives of the British Museum in London. It is recalled that study of the original report revealed that the ubiquitous manganese nodule, encountered by the expedition at great water depths in all the world's oceans except the Arctic, was in fact a highly mineralized substance that, if it were on land, would represent a valuable source of manganese, iron, copper, nickel, and cobalt. The value of contained metals at the then-current prices would make this material commercially competitive with the ores of any of these metals, on a weight basis; and the fact that the nodules appeared to be extremely widely distributed in the commons of the deep-seabeds led to a number of interesting proposals for their immediate exploration and exploitation.

Private companies in Canada, USA, Germany, and France mounted prospecting expeditions to verify the historic accounts of Sir John Murray, chief scientist of the Challenger, and were quickly followed by representatives of the governments of Japan and the United States. No expedition returned empty handed and the potential for boundless resources of minerals, lying for the taking beneath the waters of the High Seas, caused concern for the delegates to the Seabed Committee.

It was immediately apparent that some appropriate and equitable control would be needed to prevent a "nodule rush" or "high seas land grab" since claims were already being made and disputed among the participating parties at sea.

In 1970 the General Assembly of the United Nations adopted a Declaration of Principles (General Assembly resolution 2749 (XXV)), following upon negotiations which took place in the Seabed Committee, declaring that "The sea-bed and ocean floor, and the subsoil thereof, beyond the limits of national jurisdiction...as well as the resources of the area, are the common heritage of mankind" and "shall not be subject to appropriation by any means by States or persons". In addition, it was declared that this area "shall be open to use exclusively for peaceful purposes by all States without discrimination".

At about the same time, starting in January 1974, private companies in the United Kingdom, United States, Canada, Japan, Belgium, Italy and Germany were forming industrial consortia with the expressed purpose of exploring for and mining deposits of these minerals. **The Kennecott Consortium (KCON)** was formed in January 1974 and included Kennecott Corporation (parent company being Sohio of the US), Rio Tinto-Zinc Corporation of the United Kingdom, British Petroleum Company, Ltd. of the United Kingdom, Noranda Mines, Ltd. of Canada and the Mitsubishi Group of Japan. In May 1974, **Ocean Mining Associates (OMA)** was formed as a partnership registered in the United States, with United States Steel Corporation of the US, Union Miniere of Belgium, Sun Company of the US and Ente Nazionale Idrocarburi of Italy as partners. **The Association Francaise pour l'Etude et la Recherche des Nodules (AFERNOD)** was also established in 1974 in France and consisted of France's Centre National pour l'Exploitation des Oceans (CNEXO), the Commissariat a l'Energie Atomique, Societe Metallurgique le Nickel and Chantiers de France-Dunkerque. In March 1974, the **Deep Ocean Resources Development (DORD)** Company was formed as a public corporation in Japan. Its membership comprised most of the heavy metals group in Japan. In February 1975, **Ocean Management Inc.** was incorporated in the US with the following participants; Inco Ltd of Canada, Metallgesellschaft AG, Preussag AG, and Salzgitter AG of Germany, SEDCO, Inc. of the US and Deep Ocean Mining Company, Ltd. (DOMCO) of Japan. The **Ocean Minerals Company (OMCO)** was a consortium formed in November 1977 by Amoco Ocean Minerals Co. (a subsidiary of Standard Oil of Indiana, United States), Lockheed Systems Co. (a subsidiary of Lockheed Aircraft Corporation of the United States), Ocean Minerals, Inc. of the United States, Billiton B.V.--- (a subsidiary of the Royal Dutch/Shell group of the Netherlands and BKW Ocean Minerals BV (a subsidiary of the Royal Bos Kalis Westminster group of the Netherlands).

In late 1973 the Third United Nations Conference on the Law of the Sea was convened. After arduous negotiations, the concept of the “parallel system” was arrived at as a compromise in 1976. Under the system, the body empowered to administer the common heritage of mankind and to regulate its exploration and exploitation will be the International Seabed Authority. Not only would the International Seabed Authority be entrusted with the power to directly regulate purely commercial activities, but it would also be empowered to engage in seabed mining in its own right, through its commercial arm, the Enterprise.

In 1970 and 1972, the French group, AFERNOD, conducted tests of the Continuous Line Bucket (CLB) system for mining polymetallic nodules. In 1974 and early 1975, KCON tested the capabilities of a towed collector. During 1977 and 1978, OMA tested an airlift system with a towed collector. Approximately 500 tons of material was collected with a system with a design capacity of 1200 tons per day. OMI conducted tests with both hydraulic pump and airlift, and towed collectors in early 1978 and recovered 1000 tons over a few days. Finally in 1978 and 1979, OMCO tested an airlift system with a remotely-controlled, self-propelled collector. To provide a bridge from the developments during this period until the present day, the Authority invited other experts familiar with the early industrial activities in the Clarion-Clipperton Fracture Zone (CCFZ). Indeed the paper and presentation by Mr. Ted Brockett provided the workshop with such information.

In this part, representatives of the registered pioneer investors, some of whom were not involved in the early industrial activities, were requested to prepare and present papers on their activities with regard to the development of exploration and mining technology for deep seabed polymetallic nodules. They were also requested to inform the Authority of the scope that existed for cooperation, whether in the form of cooperation among themselves, or with independent research institutions and other kinds of researchers. This was discussed during the final part of the session and is reported in Part Four of the proceedings.

Chapter 8 contains the paper, presentation and summary of discussions on “The Japanese experience in deep seabed exploration technology”. Presented by Dr. Kazuo Shuto of Deep Ocean Resources Development Company of Japan, the session provided information on the technologies developed and used by the Japanese pioneer investor for polymetallic nodule prospecting. Chapter 9 contains the paper, presentation and summary of the discussions on “An environmentally friendly Deep Seabed Mining System”. Presented by Mr. Feng Liu of China Ocean Minerals Resources R&D Association, the session provided information on the mining system presently under development by the Government of the People’s Republic of China.

Chapter 10 contains the paper, presentation and summary of discussions on “Scientific and Technological R&D related to Deep Seabed Mining”. Presented by Mr. Guy Herrouin of IFREMER, the session provided information on work that had either been completed or was underway by the French pioneer investor. Chapter 11 contains the paper, presentation and the summary of discussions on “Japan’s Nodule Collector test on a Seamount”. Presented by Dr. Tetsuo Yamazaki of the National Institute for Resources and Environment of Japan, the session provided information on a successful large-scale test that was conducted by the Japanese pioneer investor in 1997. Chapter 12 contains the paper, presentation and summary of the discussions on “Research and Development of Mining Technologies for Polymetallic Nodules in Korea”. Presented by Dr. Sup Hong of the Korea Ocean Development System Research Centre, the session provided information on the history of, and design concepts that are being developed by the Korean pioneer investor for full-scale commercial mining in 2010 or later. Chapter 13 contains the paper and presentation on “An Overview of the Indian Polymetallic Nodule Programme”. Its author, Professor M. Ravindran was, unfortunately, unable to participate in the workshop. His Excellency, Mr. B. Gupta, High Commissioner of India to Jamaica therefore presented the paper.





## Chapter 8

### THE JAPANESE EXPERIENCE IN DEEP SEA BED EXPLORATION TECHNOLOGY

*Dr. Kazuo Shuto*  
*Deep Ocean Resources Development Company Ltd. (DORD)*  
*JAPAN*

**Concept of Exploration Grid Space**

**Navigation System**

**Geological Survey**

**Geophysical Survey**

**Evaluation of Distribution Density of Manganese Nodules**

**References**

**Summary**

## CONCEPT OF EXPLORATION GRID SPACE

Japanese (DORD's) prospecting for manganese nodules is characterized by the so-called "progressively closer prospecting method", increasing the accuracy of investigation as the survey progresses. Target area prospecting proceeds from a 42.4 nautical mile grid spacing down gradually to a half of the precedent grid space in samplings.

The fundamental chart used for the survey was marked by sectioning datum lines at every 18° (60 miles) in latitude and longitude. As the sampling operations were based upon this chart, the precision of surveying stations for the primary and secondary surveys were chosen and described as follows:

Primary stage: Stations for sampling were fixed on a 42.4 nautical mile grid connecting the crossing point of sectioning lines at every 1° (60 miles) in latitude and longitude to the center of the section.

Secondary stage: Stations covering the middle stations of the primary stage were added and the sampling point interval was reduced to a 21.2 nautical mile grid.

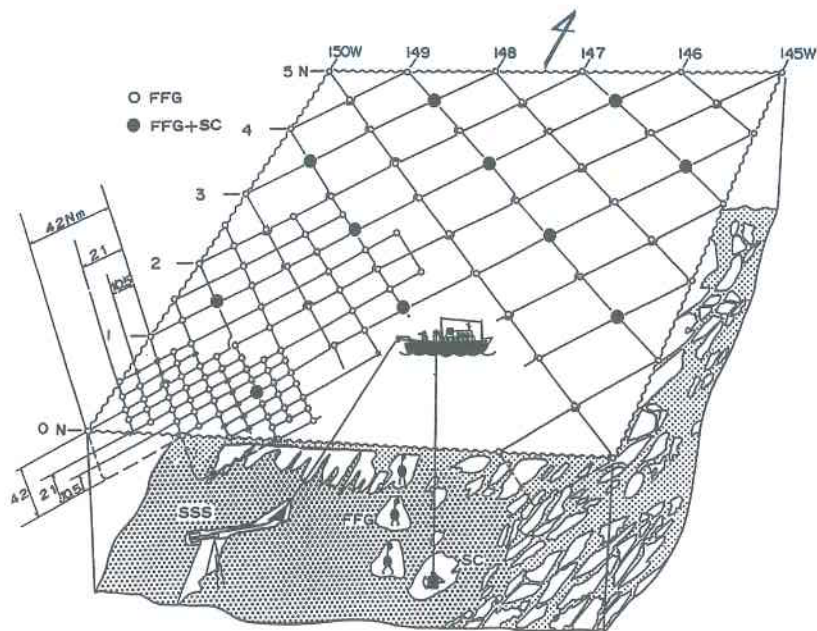

Progressively Closer Prospecting Method  
Primary survey station: 42.4 nautical mile grid  
Secondary survey station: 21.2 nautical mile grid

## Space of Sampling Stations

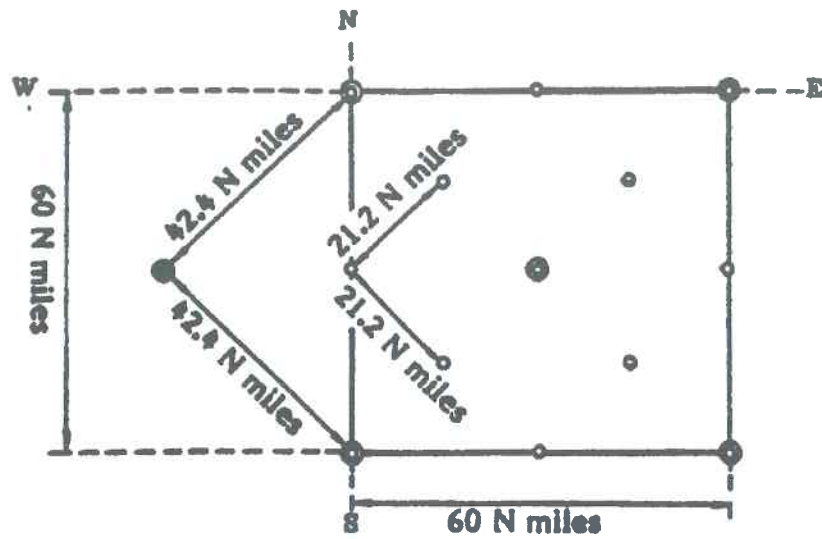

Primary survey station: 42 nautical mile grid

Secondary survey station: 21.2 nautical mile grid

Notes (1) 60 nautical mile section correspond to every 1°  
in latitude and longitude

Notes (2) 1 nautical mile equals to 1.852 km

## Explanation of the Setting Order at a Sampling Station

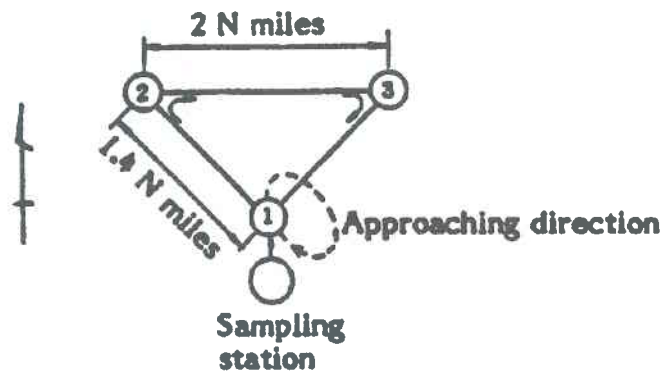

## NAVIGATION SYSTEM

Global Positioning System (GPS) is used to determine the ship's position. The signals from satellites and data from the electro-magnetic log, and gyrocompass enter into the high-performance navigation survey and data logging systems, which calculates latitude and longitude for positioning. CRT (Cathode-Ray Tube) displays position information in laboratories, bridge and various places on the research vessel, Hakureimaru No. 2.

The automatic navigation system steers the vessel along the estimated survey line by outputting the processing unit's command signals into the electric driven helm control system.

## GEOLOGICAL SURVEY

Free-fall Grabs (FFG), Spade Corers (SC), and Piston Corers (PC) are involved in direct sampling of manganese nodules and sediments from sea floor, rocks from sea mounts and sea hills. A Continuous Deep-sea Camera (CDC) is used for close observation and photography of the sea floor. Manganese nodule samples are examined for their shape, size, specific gravity and metal content; mainly nickel, copper, cobalt and manganese, as well as, the tonnage of per unit area deposits or distribution density ( $\text{kg}/\text{m}^2$ ) (abundance). The data are used to determine the final metal content of manganese nodules and the amount of ore reserves at each deposit.

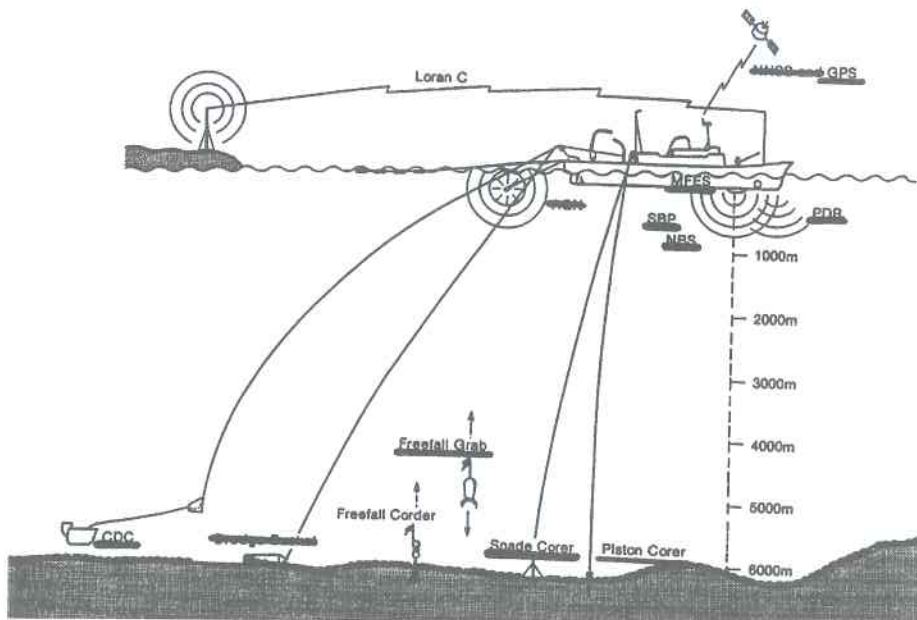

## Free-fall Grab (FFG)

A free-fall grab, consisting of a float, grab and ballasts, collects manganese nodules and small amounts of sediment samples by falling with its own weight when it is launched into the water. Upon contact with the sea floor, the ballasts are automatically released, causing the float to raise the grab. As it ascends, the lever arm closes and traps the nodules into the sampling net. Sediment samples are collected in a tube. The float overcomes the weight of the samples and surfaces, after which the grab is located by a radio marker or lamp beacon.

### Free-fall Grab Sampler's Specifications

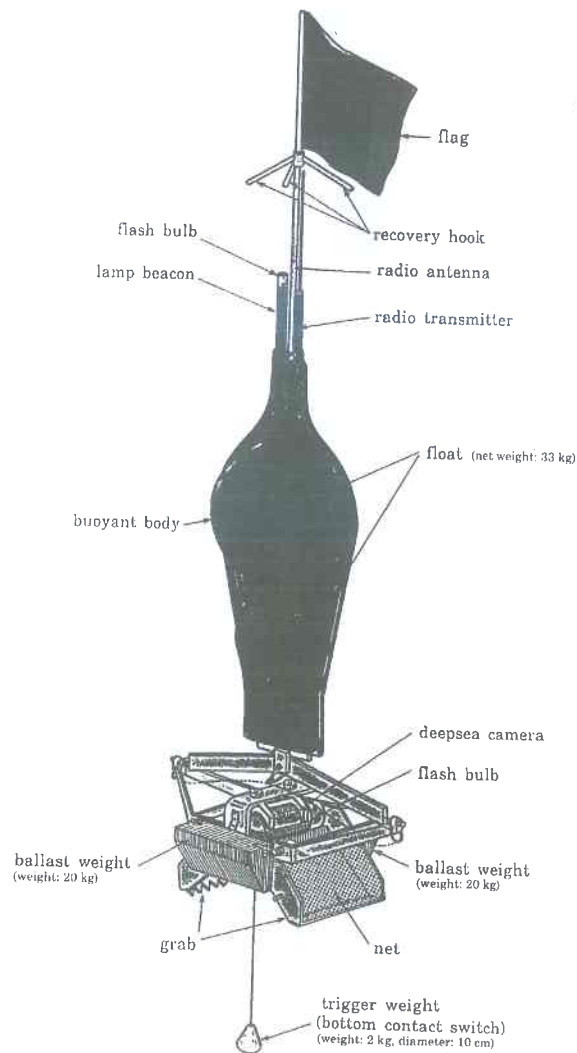

## Functioning of Freefall Grab Sampler

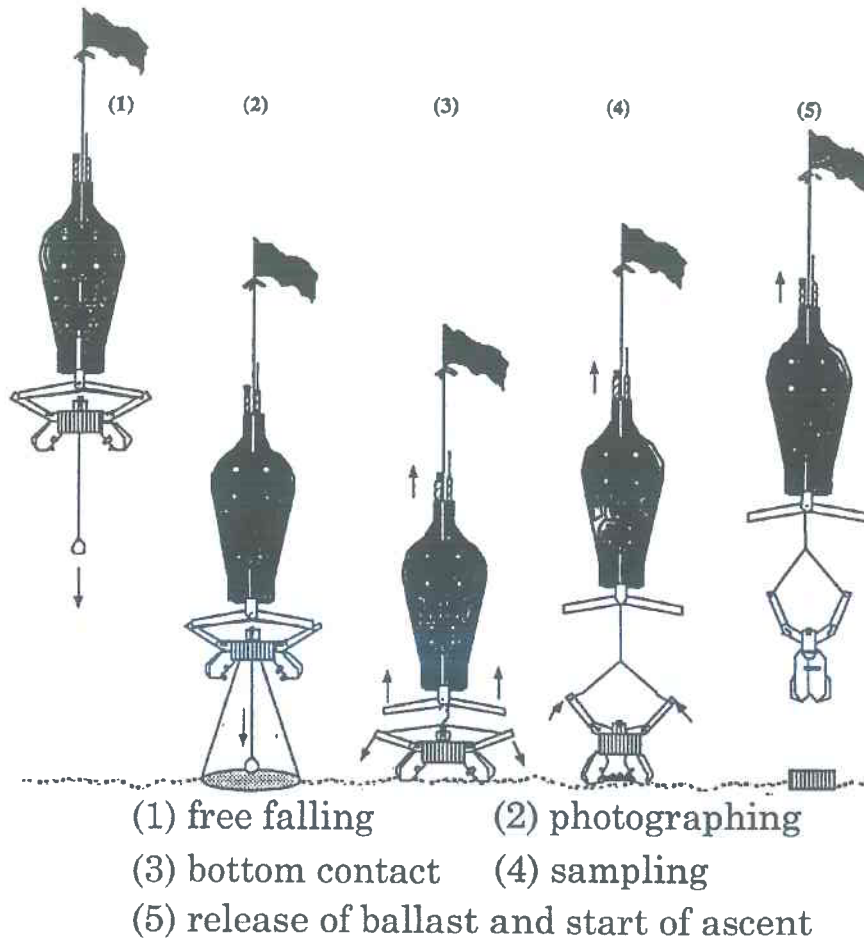

## Spade Corer (SC)

A spade corer is a type of box corer, lowered into the water by a winch. The size of the installed sampling box is about of 50 cm wide, 50 cm long, and 50 cm high.

Upon contact with the sea floor, the sampling box penetrates into the sediment and the spade trigger works simultaneously. After confirmation of the spade's cutout of the sub sea-bottom sediment just below the sampling box, the sampler is then lifted with an almost undisturbed sediment sample, and together with samples of manganese nodules are collected with the same appearance as on the sea floor.

## Functioning of Spade Corer

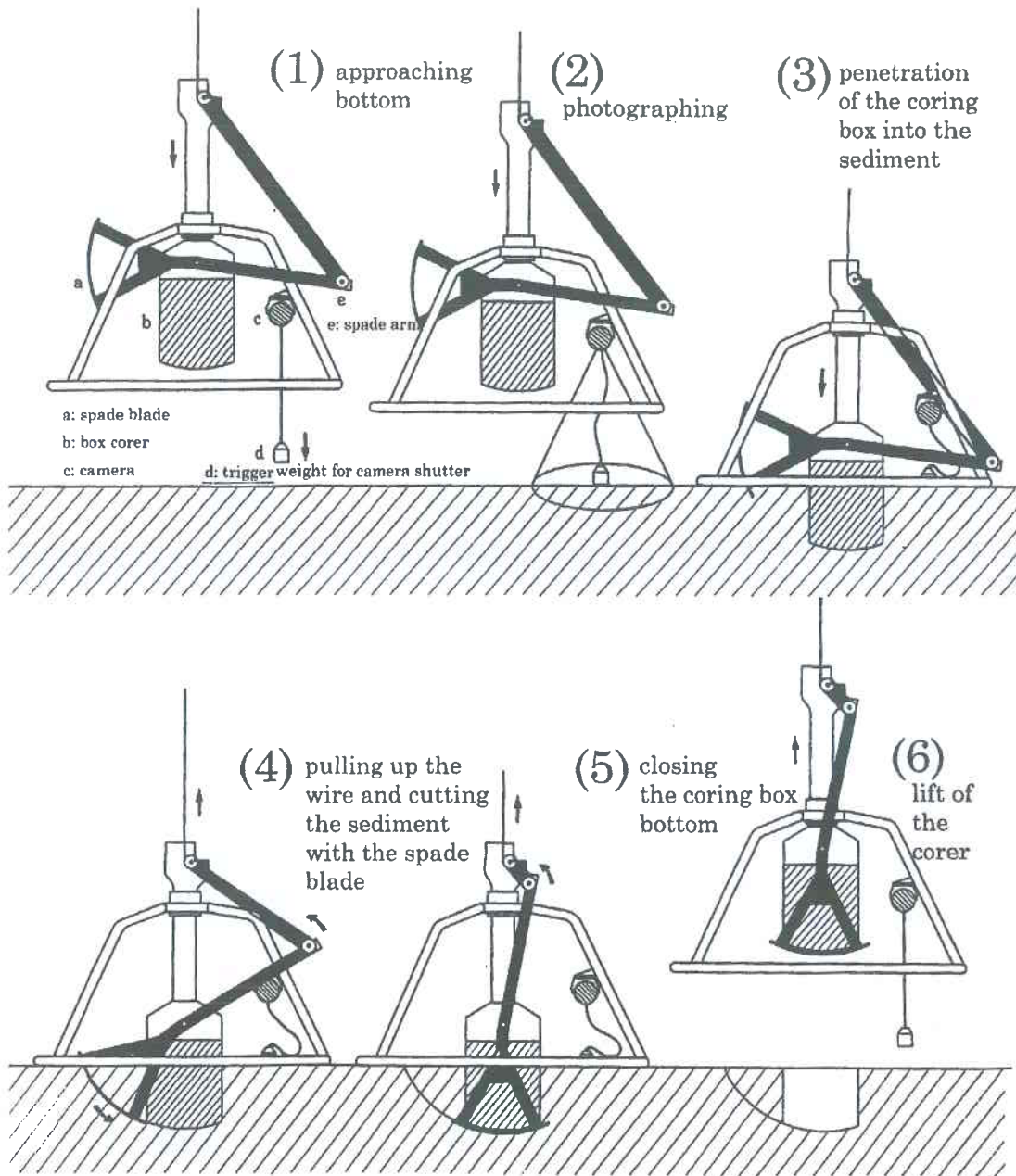



## Piston Corer (PC)

A piston corer is used to get longer sediment samples than the spade corer. The sampler, consisting of a long core tube and weight, is lowered into the water by a winch. Upon contact with the sea floor, the core tube penetrates into the sediment by means of weight and collects the sample. The corer is then lifted. At the bottom end of core tube, the core retainer is installed.

### Functioning Piston Corer

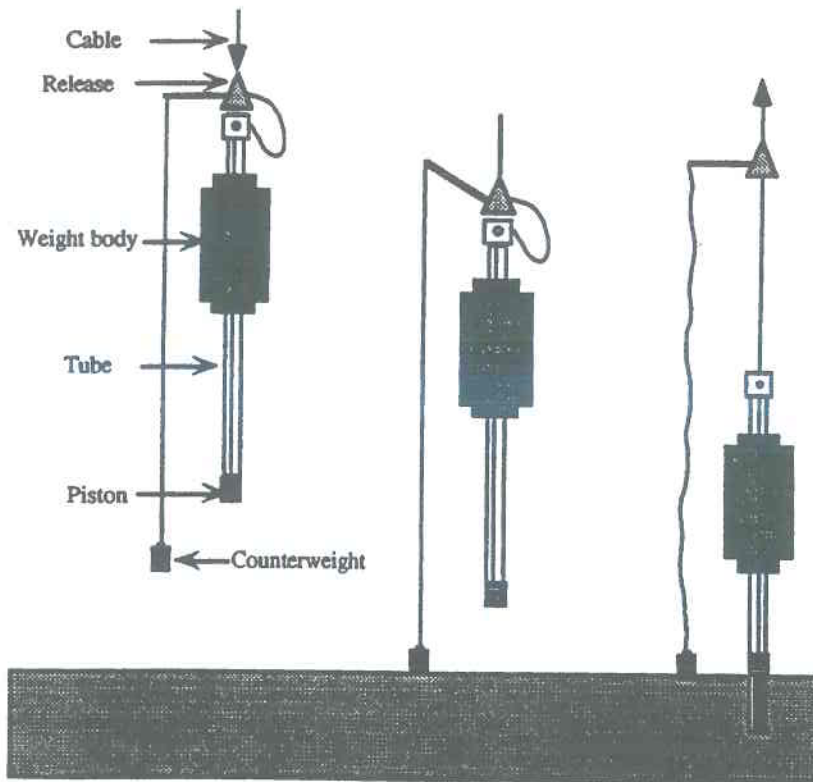

## Sampler-mounted Still Camera

A deep-sea camera system is mounted on the free-fall grab, spade corer and others to photograph the sea-bottom immediately before sampling. The camera is contained in a housing resistant to pressures in 6000 m deep waters, and has a 2.0 kg weight suspended from a wire string which acts as an electromagnetic shutter release for shooting at the moment of the ballast's contact with the sea bottom. This mechanism is called a "Bottom Contact Switch"

# Functioning of Spade Corer

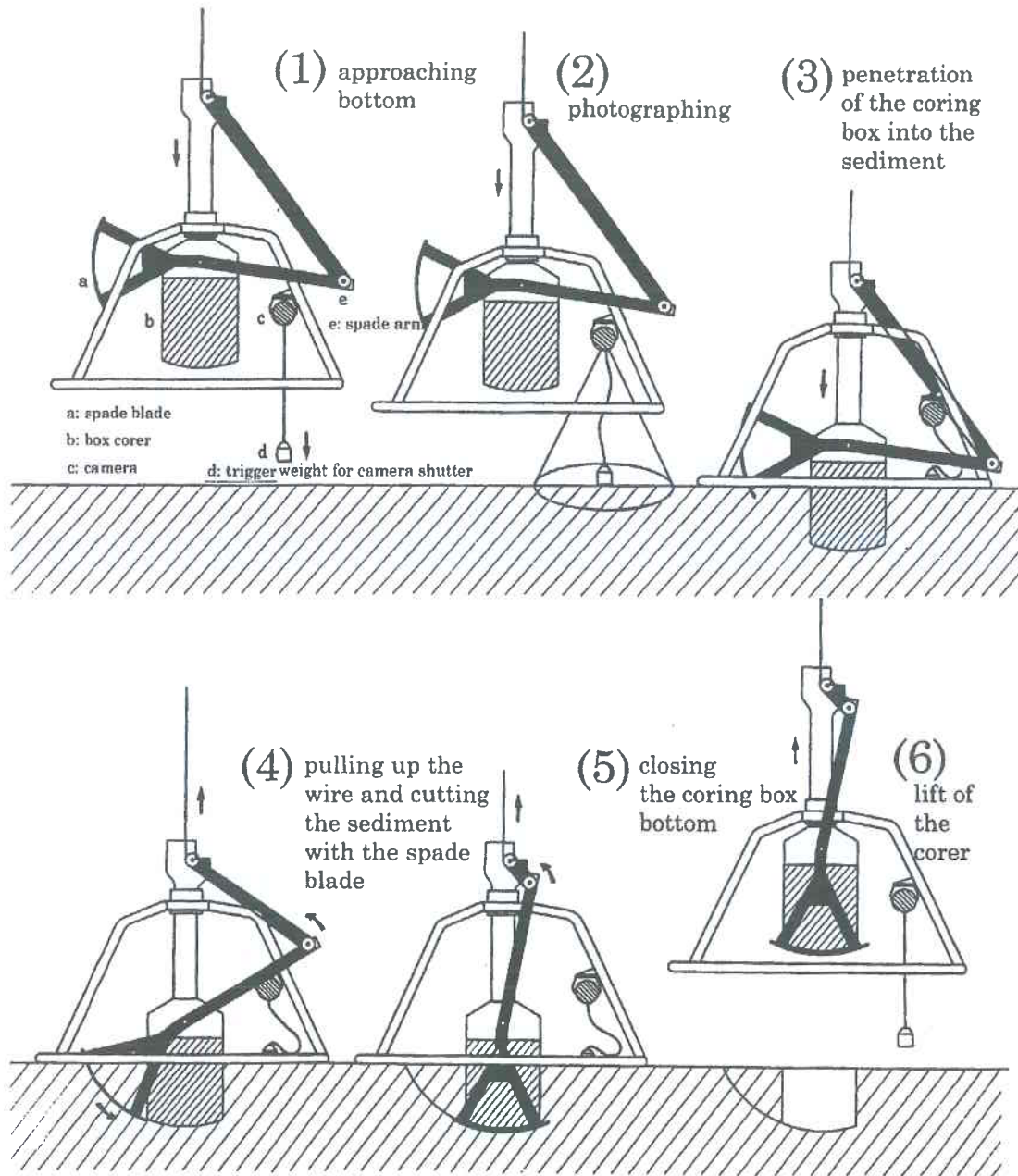

## Piston Corer (PC)

A piston corer is used to get longer sediment samples than the spade corer. The sampler, consisting of a long core tube and weight, is lowered into the water by a winch. Upon contact with the sea floor, the core tube penetrates into the sediment by means of weight and collects the sample. The corer is then lifted. At the bottom end of core tube, the core retainer is installed.

### Functioning Piston Corer

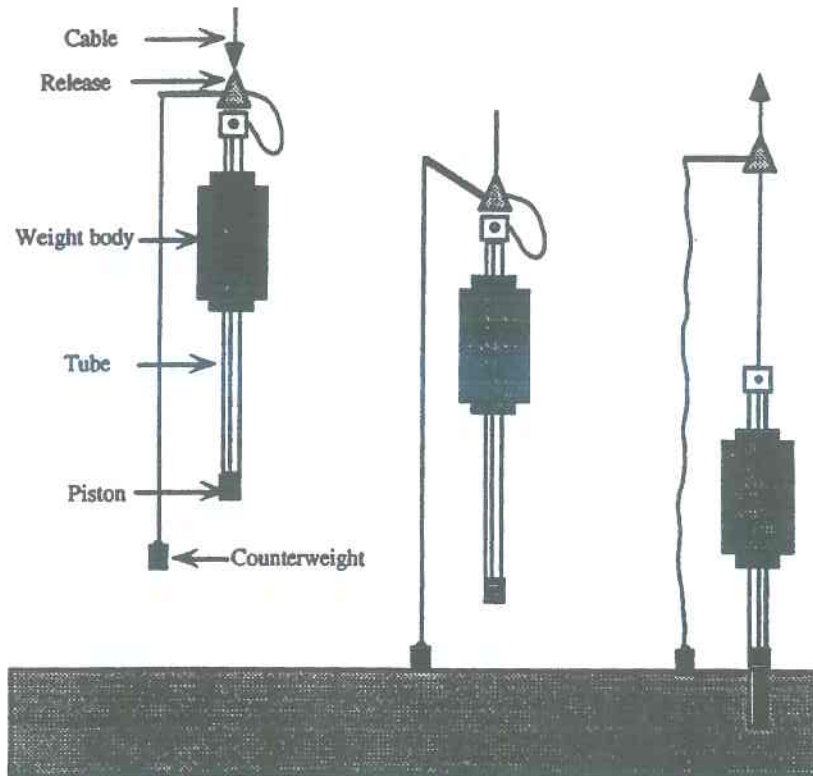

## Sampler-mounted Still Camera

A deep-sea camera system is mounted on the free-fall grab, spade corer and others to photograph the sea-bottom immediately before sampling. The camera is contained in a housing resistant to pressures in 6000 m deep waters, and has a 2.0 kg weight suspended from a wire string which acts as an electromagnetic shutter release for shooting at the moment of the ballast's contact with the sea bottom. This mechanism is called a "Bottom Contact Switch"

## .Continuous Deep-sea Camera (CDC)

The continuous deep-sea camera system provides a series of photographs of the ocean floor as a visual survey method for manganese nodules. A suspended triggering device activated by contact with the bottom takes photographs by conventional still camera in the system.

### Sampler-Mounted Still Camera (for FFG & SC)

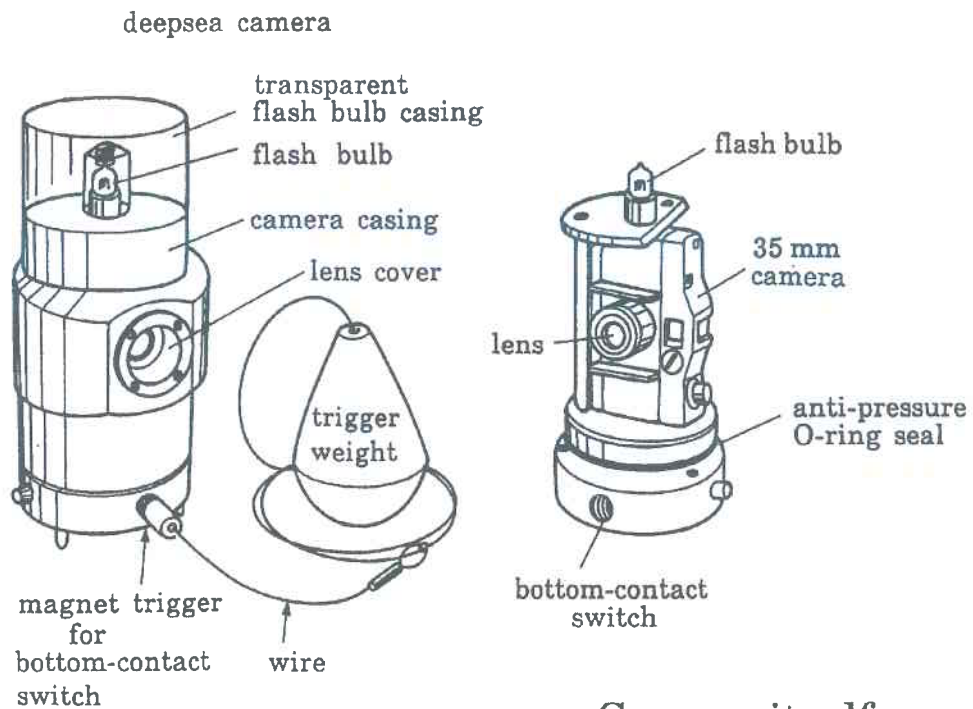

### Casing and Weight

### Camera itself

## **GEOPHYSICAL SURVEY**

Geophysical survey by a sub-bottom profiler (SBP) for the sea-bottom and sub-bottom are made from reflection sound pressures of a low frequency sound. Precision depth recorders (PDR), narrow beam sounders (NBS) and sub-bottom profilers (SBP) are used to examine sea floor topography along the survey line. A multi-frequency exploration system (MFES) provides information on the distribution density of manganese nodules by measuring acoustic sound pressures.

### **Sub-Bottom Profiler (SBP)**

A Sub-Bottom Profiler uses acoustic waves of 3.5 kHz to operate and is capable of identifying physical properties of sedimentary formations that have differences in acoustic characteristics between ooze layer and sediment, below the sea bottom surface.

### **Precision Depth Recorder (PDR)**

This recorder system combines a precision depth recorder with a sub-bottom profiler, designed as an integrated water depth measuring system that minimizes mutual interference. The data from the PDR is sent to a processing unit to create depth records, which in turn are used to form topographical profiles. The echo sounder transducer housed in the sonar dome emits a wave of 12 kHz and amplifies and records the waves returned from the sea-bottom to plot a sea-bottom profile.

### **Narrow Beam Sounder (NBS)**

The Narrow Beam Sounder System is a high performance echo-sounder for general and specific measuring tasks in oceanographic research such as oceanography, marine biology (fish, plankton, scattering layers) and morphology. Because of the acoustical output, the range of applications extends even to great depths. For exact measurement, an optimum resolution even in difficult areas (steep inclines, cleft, and uneven bottom etc.) is essential. The requirements of a large range, high measuring accuracy (resolution) and penetration power into the bottom and layering are partially contradictory.

In order to achieve optimum results under these working conditions, the system has been provided with three frequencies, which can be chosen as required. A precondition for a high power of resolution of the measurement is an extremely sharp focusing of the transmitted or received ultra-sonic waves. The narrow beam widths ( $2.6^\circ$  at 30 kHz) are attained by a transducer with a large surface.

## Multi-Frequency Exploration System (MFES)

### *Purpose*

The Multi-Frequency Exploration System has the noteworthy feature of providing a continuous flow of information about the distribution density of manganese nodules between grab sampling stations, although it is generally used as a sea-floor reconnaissance survey facility. The estimation of continuity of the manganese nodules provides input for the selection of target areas for more detailed exploration in the future.

### *Methodology*

MFES should adopt a degree of exploration accuracy suited to the grab sampling intervals in the respective phases of exploration. The proposed MFES tracking lines of a research vessel should link existing or proposed sample stations. Sub-bottom profiler (SBP) data is important for the interpretation of MFES data because it reveals acoustic features of superficial sediments on the sea floor.

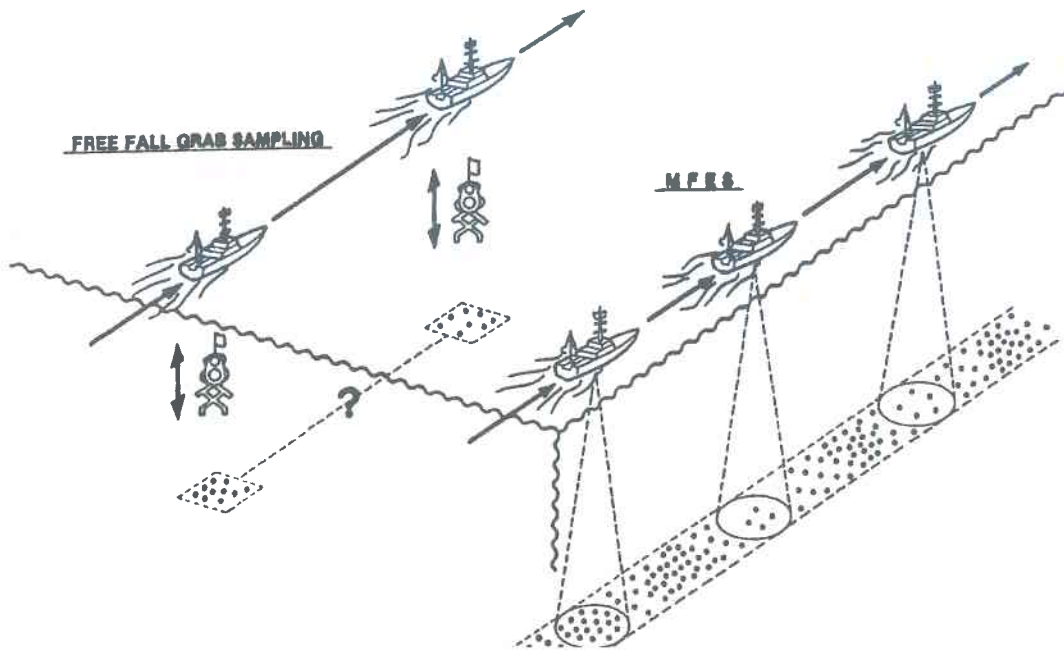

Multi-Frequency Exploration System and Freefall Grab Sampler

### *Evaluation of MFES data*

The areas showing high density by means of both grab samples and MFES must be considered as areas of high abundance of manganese nodules, unless ridges and hills, which consist probably of solid rocks, are assumed to be between sampling stations.

The areas showing low density by means both of grab samples and MFES must be considered as areas of low abundance of manganese nodules. It is advisable to exclude them from target areas for more detailed exploration.

The areas where grab samples show poor abundance of manganese nodules, but where MFES shows high density, call for cautious treatment. Where the sampling grid intervals are large, closer grab samplings are necessary. It is possible to estimate by a SBP the presence, between sampling stations, of materials showing high acoustic reflectance, instead of manganese nodules.

The areas where grab samples show high abundance of manganese nodules, but where the MFES shows low density must also be treated cautiously. Where the sampling grid intervals are large, closer grab samplings are necessary.

### *Expected effectiveness*

Combined exploration with grab samples and MFES provide information not only on the continuity of manganese nodules between grab sampling stations, but also for checking contour maps drawn by using grab sampling data.

It is possible that the combined exploration approach provides a more accurate estimate of the abundance of manganese nodules than grab samples only. The areas reserved for the Authority could be effectively narrowed down to the smaller areas, where future detailed exploration could be carried out by adopting the combined approach.

### *Applicability*

The frequencies of acoustic sounding instruments, such as conventional echo sounders and the sub-bottom profiler, should theoretically be in the following ranges to obtain the best quality; since the target nodule size is from several to over ten centimeters in diameter.

- f 1 : 3 - 5 kHz Sub-bottom profiler (SBP)
- f 2: 8-15 kHz Precision depth recorder (PDR)
- f 3 : 25-35 kHz Narrow beam sounder (NBS)

At the early stage of prospecting, a combination of only two frequencies may also be envisaged.

### *System description*

Input signals to MFES comprise transmitter waves from acoustic sounding instruments and sound pressure of received waves. Upon receiving the trigger signals of transmitted waves, a window is opened for a previously set period in order to receive reflected waves. The system processes the received reflected waves. In digital processing, a water depth correction is made, based on the travel time of the received signals. After this operation, the MFES data are calculated continuously from sound pressure data from NBS, PDR and SBP. The results are stored in the file server and the on-line MT by the data processing system.

### **Multi-Beam Echo Sounder (MBES)**

The multi-beam echo sounder is a depth sounding system capable of producing an extensive and continuous ocean floor topographic map. The MBES has a receiver and a transmitter installed on the ship's bottom in a T-figure. Sonic waves are approximately 15.5 kHz and the coverage is approximately 10 km wide over the seabed in 5,500 m water depth.

### **MBES**

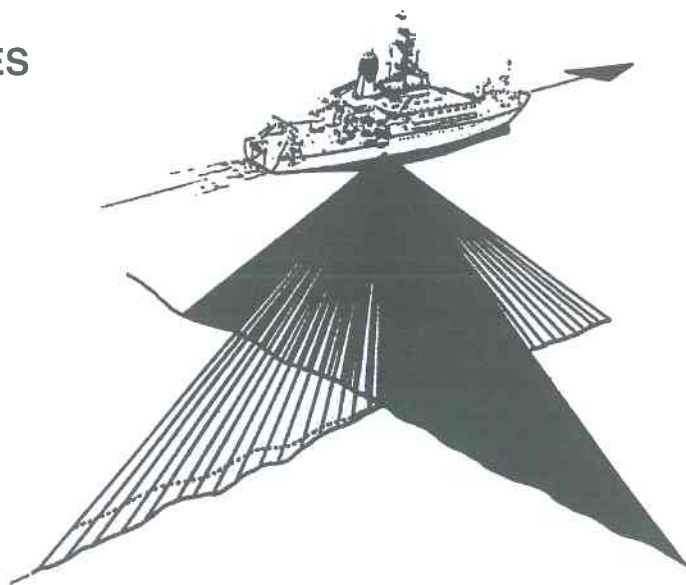



## EVALUATION OF DISTRIBUTION DENSITY OF MANGANESE NODULES

The geological team and geophysical team carry out the exploration work respectively. The main techniques used in exploration are bottom sampling and acoustic sounding.

### The System of the Geological Survey

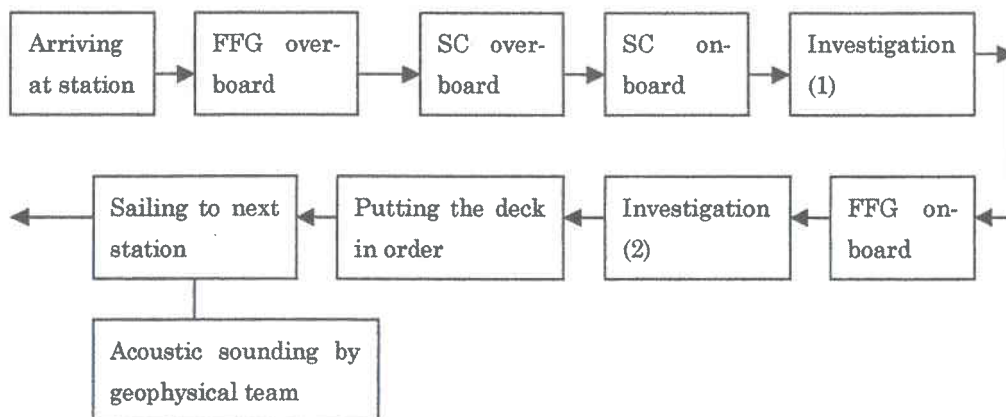

#### Investigation 1

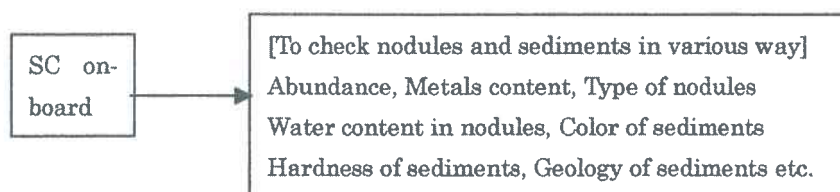

#### Investigation 2

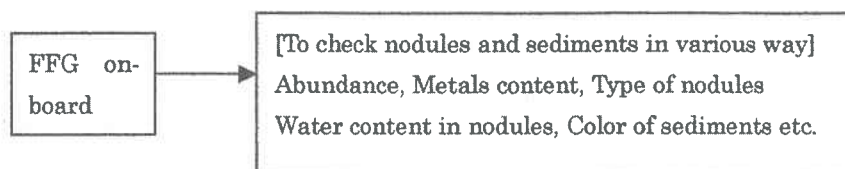

## The System of the Geophysical Survey

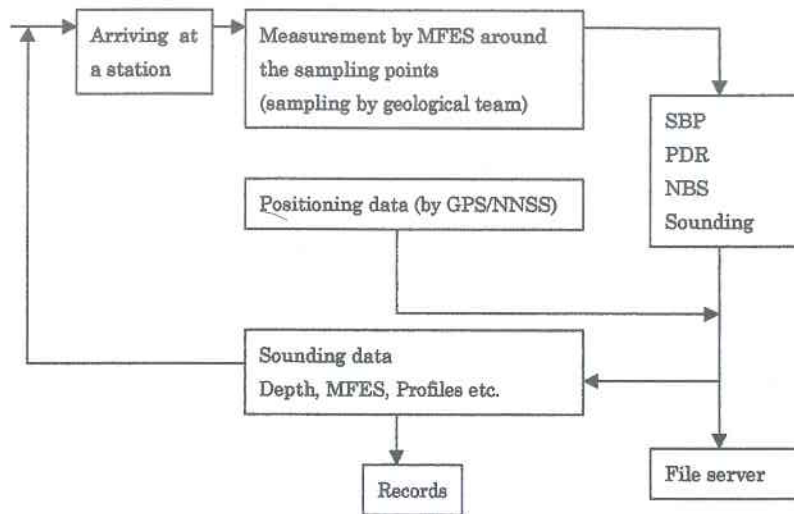

## Evaluation of Manganese Nodules

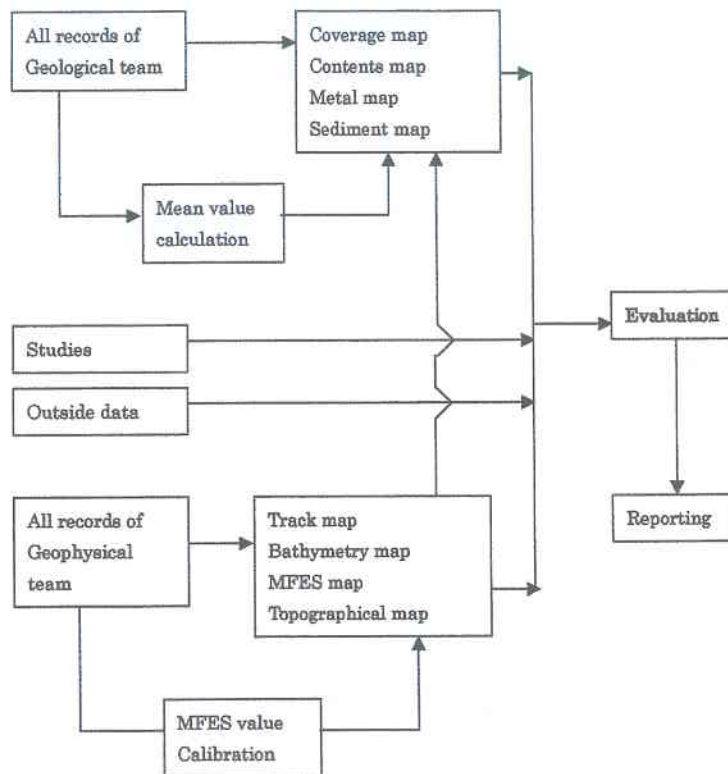

## REFERENCES

- Japanese Government (1988): Application for registration as a pioneer investor by  
The Japanese Government on behalf of Deep Ocean Resources Development Co. , LTD
- Shozo Sawaya, Kazuo Shuto(1990): Japanese activities of deep sea mineral resources prospecting in  
the Pacific Ocean PACON 90
- IFREMER .DORD .YUZHMOERGELOGIYA (1991):  
Preparatory Work in the International Authority Reserved Area.
- Metal Mining Agency of Japan (1994):" Sea Future" M MAJ

## Summary of the presentation and discussions on the Japanese experience in deep seabed exploration technology

The Japanese Experience in Deep Seabed Exploration was described by Dr. Kazuo Shuto, of Deep Ocean Resources Development Co. Ltd, (DORD). He outlined the work carried out in prospecting for nodules which was characterized as the “progressively closer prospecting method”. Target areas were characterized on a square grid of 42.4 nautical miles and subsequently in more detail on a grid of 21.2 nautical miles. Navigation was by Global Positioning System (GPS). Geological sampling equipment at grid points included free-fall grab, spade corer, and piston corer aided by sampler-mounted cameras and a continuous deep-sea camera for visual continuity between sampling stations. Geophysical surveys were carried out using a 3.5 kHz sub-bottom profiler (SBP), an 8-15 kHz precision depth recorder (PDR), a 25-35 kHz narrow beam echo sounder and a multi-frequency exploration system (MFES). The MFES provides a continuous flow of information on nodule distribution and density between the sampling stations as well as being used for reconnaissance surveys. The MFES synthesizes the data from each of the instruments using a digital format and correcting for water depth. It was suggested that this combined system may provide a more accurate estimate of nodule abundance than sampling by itself.

Discussions centered on the reliability and accuracy of prospecting in terms of evaluation of the resource, considering the variation in nodule size and distribution and what appeared to be significant areas of either barren sediment or sediment covered nodules. The use of the term *reserves* rather than resources by the speaker led to some further discussion on this important issue.

### Sampling accuracy

Relating to the accuracy of sampling in relation to the acoustic records and the calculation of the actual location of the free-fall grabs relative to their release point, the speaker explained that they dropped free-fall grabs with 20kg iron weights at three points in each station and retrieved them about 2 or 3 hours later. Although the drops were positioned by GPS, in reality it was not possible to know exactly where they hit the bottom.

When using transponders on the samplers, the correlation between the samples and the acoustics was good even though there was a variation in nodule

density across a very wide stretch of sea floor. The accuracy between the acoustic data and the sample set was not calculated but with combined photographs it was possible to check the accuracy to some extent. Profiles of the seabed, especially the sub-bottom, were very good. There was a transparent layer there and the nodules were in high contrast to the seabed. Despite this, the 5000m of water between the transducer of the hull-mounted acoustic system and the seabed resulted in a huge spread of the acoustic data which is the reason that moving averages were taken over 3000m. However, there were no calculations available at that time on their reliability.

### **Nodule size and location**

Reference was made to the smallest size of nodules recorded in the resource estimation, the sizes potentially recoverable by mining, and the expected depth of cut to remove them. Dr. Shuto indicated that the smallest nodule was about 5 mm and the biggest maybe 20 or 50 cm. The larger sizes were rare and the mining system might be limited to recovery of those below 20 cm as the deepest nodule projection in the mono-layer would then be about 10 cm. A participant made the point that in the Japanese mining industry it is assumed from the spade, or box corer data that 99% of the nodules are on the surface. The speaker agreed and indicated that in his experience about half of each nodule is buried, so 10 cm or sometimes 5 cm is normally the number used for the depth of the bottom cut.

### **Resources and ore reserves**

In questioning the smallest economic area or mining unit (SMU), it was pointed out that, according to international standards, ore reserve statements are not valid unless they include a cutoff grade; and the use of the words resource and reserve by the speaker was in conflict with the accepted international standards of usage of those terms in the mining industry. Another participant said the word ore may only be used when there is a completed feasibility study saying the material will be mined at a profit. All these words are defined and agreed upon by national bodies in Australia, Canada, UK, USA, and other countries and once financing is involved the correct use of these terms is extremely important. Even the UN has a classification of resources and reserves that is accepted by financial stock exchange institutions around the world and it has also been adopted by the European Community (EC).

The speaker explained that his numbers were only estimates from the data acquired, and it was further pointed out that there was a problem of language because the Law of the Sea Convention does not differentiate between reserves and resources. People are using both words in a different sense. It is clear in fact that

with respect to nodules at this time there are no ore reserves but only potential reserves and even the methodology that has been used to estimate the resources is questionable by international standards.

### **Accuracy of estimates**

Referring to photographic surveys one participant indicated that as soon as the nodules are embedded completely in the sediment it is rather difficult to make any calculation because there is no nodule surface to photograph. Sometimes nodules are recovered from a grab sample when a photograph, taken at the same spot, does not indicate any presence of nodules on the bottom. Nodules considered to be potential ore are generally lying on the top of the sediment, or even embedded in the sediment near to the top, at probably less than 5 cm. Photography will not record nodules that are completely buried and therefore photographic interpretation may underestimate the amount of the resource.

The French researchers at the beginning of prospecting made the same kind of calculation that Dr. Shuto had described to compare their grab system results with their photographs. Those areas without apparent nodules were not taken into account. It was discovered later, when diving with the *Nautile*, that those areas were sediment covered mounds, made by worms, that buried the nodules. When the results were compared with those of the Japanese and the Russians in an area reserved for the authority they were found to be 20% lower. All the photographs were checked again and it was found that the difference was due to these factors. That is one of the difficulties in making evaluations.

Another participant had faced the same problem with diamonds and stressed that for estimation of a reserve, a variation of just a few percent in the cut-off grade can make a big difference to the economics and reserve figures. That is why it was important to know, not by photography but by some other means, how many nodules were present. Returning to the French experience in diving, it was pointed out that when the nodules were present, there were plenty of them so the problem for the time being was to select areas with plenty of good nodules. In the future perhaps other areas could be considered. It was also said that buried nodules are very common in the central Indian Ocean basin area.



## Chapter 9

### **ENVIRONMENTALLY- FRIENDLY, DEEP SEABED MINING SYSTEM**

*LIU Feng*

*China Ocean Mineral Resources R&D Association (COMRA)*

*YANG Ning*

*Changsha Research Institute of Mining and Metallurgy  
People's Republic of China*

**Abstract**

**Main Principles of Designing a Deep Seabed Mining System**

**Model Mining System Developed by COMRA**

**COMRA's Efforts to Develop a Future Mining System**

**International Cooperation –  
Cost-effective Way to Achieve the Common Goal**

**Conclusions**

**References**

**Summary**



## ABSTRACT

The existence of manganese nodules on the deep seabed has been known for more than a century since they were discovered by an English vessel, the R/V Challenger in 1873. It was in the late 1960s when enormous nodule resources were found lying on the deep-sea soil surface, forming two-dimensional deposits, being rich in strategic minerals such as copper, nickel, cobalt and manganese, which were believed to have great potential commercial values, that interest was reawakened. From that time on, this truly global resource in the Area attracted more and more world attention. Especially in the late 1970s when a campaign on development of deep seabed mining technologies was highlighted.

At the same time, the world environment within which we live and of which we are a part has become of great concern for all mankind. As one of the last frontiers on earth, the deep ocean, possessing nearly half the amount of the whole planet surface, of which we human beings will make use someday, naturally is becoming an environmental focus.

The United Nations Convention on the Law of the Sea, the Implementing Agreement and the on-going Mining Code ask for the extensive protection of the environment. Protection and Preservation of marine environment from serious harm resulting from activities in the Area have become a basic understanding for making rules, regulations and procedures. One prerequisite for an environmentally-friendly mining system will be a proven design concept. The concept for designing a deep seabed mining system should differ from that of conventional land systems. The ocean, so different from the land, forces us to think differently.

The paper first provides several principles for the design of an environmentally-friendly, deep-seabed mining system. The authors express concern about the mining system's effectiveness for nodule collecting and lifting and its reliability. These factors, if properly accounted for, can lead to less waste of nature resources and durability of the system. The health of the deep-sea environment should be ensured while use is made of its resources by human beings. Secondly, the paper presents a model system developed by COMRA and also COMRA's future plan for developing mining technologies. Finally, since deep-seabed mining is a high-risk and high-investment undertaking, international cooperation is foreseen as a suitable way for ensuring its success.

## MAIN PRINCIPLES OF DESIGNING A DEEP-SEABED MINING SYSTEM

The design of any efficient system of complex machinery depends on many factors. These include not only latest technology, but also many other factors such as the environment in which it is to be used. A deep-seabed mining system will be working in the environment of a water column from the ocean surface down to the 6000-meter, deep-sea bottom. Manganese nodules mining consequently means to separate the nodules from the semi-liquid soil layer, to lift them to a place where they can be collected, to transport them to an immediate buffer and then to a surface vessel. That is to say, the nodule collector will have to be moving on an extremely soft sediment layer, in which the collector will surely sink to a certain depth in the semi-liquid layer down to the relatively condensed soil layer. The lifting system from the bottom buffer to the sea surface will no doubt interact with the water column. To design such a mining system, assuring an operation that does not lead to serious harm to the surrounding environment and obtaining the necessary mining efficiency, is not an easy task.

In the last thirty years, more than one hundred deep-sea miner designs have been patented. These designs can be classified into four concepts. Three of these concepts have been tested at sea to mine nodules. The fourth one was tested in a laboratory tank. The four basic designs are as follows:

- The continuous line bucket system (CLB) refers to all mining systems, which have been inspired by bucket chain dredging or by oceanographic chain dredges, i.e. buckets have been fixed to a continuous line in the manner that a defined number of buckets are towed across the seafloor thus collecting loose materials at the top of the seabed (Figure 1)
- The passive towed system refers to a system in which a nodule collector on the sea bottom is towed by a pipe (hydraulic lift or air lift) of more than 6000 meters from the surface vessel (Figure 2)
- The active self-propelled system refers to a system, in which a mobile bottom miner is used. The self-propelled miner can be driven on the soft soil, collect nodules from the semi-liquid soil layer, crush them and transfer them to a buffer through a hose. A rigid pipe (hydraulic lift or air lift) connects from the buffer to the surface mining platform (Figure 3)
- The submarine shuttle system consists of individual robots, that act as a means for transporting nodules from the sea bottom to the sea surface, together with miners that collect nodules from the bottom semi-liquid soil (Figure 4)

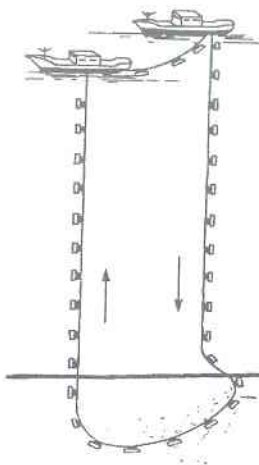

Figure 1 - The continuous line bucket system

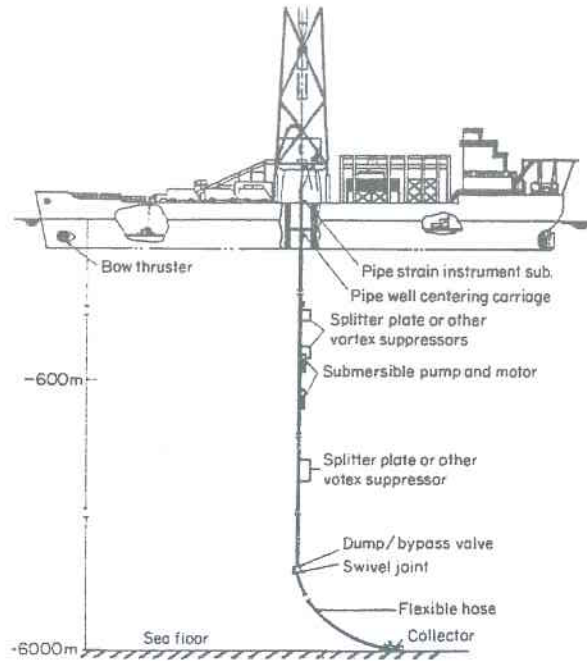

Figure 2 - The passive towed system

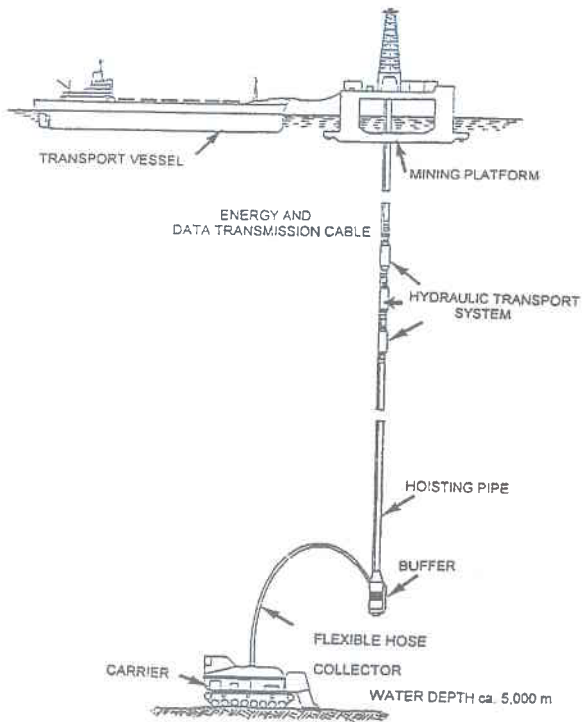

Figure 3 - The active self-propelled system

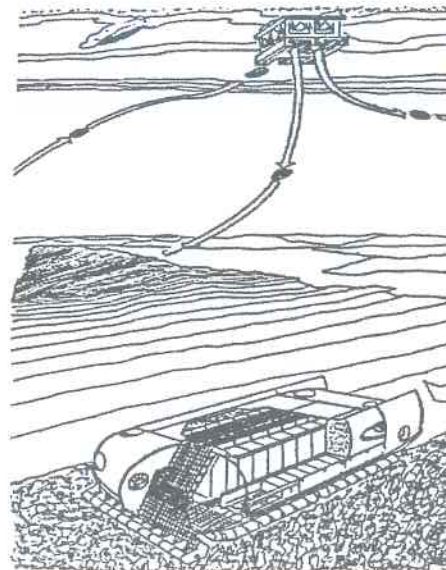

Figure 4 - The submarine shuttle system

Sea and laboratory tests have shown that using the four concepts it is mechanically feasible to collect nodules from the sea bottom and lift them to the mining vessel. Owing to the lack of solid scientific knowledge of the deep-sea environment at the time the systems were designed, manufactured and tested, some environmental factors were omitted. To make the deep-seabed mining system environmentally acceptable, amelioration of the above-mentioned concepts is required.

### **Requirements of an Environmentally Friendly Mining System**

The design and construction of the variety of mining systems seems to lead to a variety of different possible impacts from mining operations. In the meantime we know that their impact on the marine environment can be classified into three different general areas:

- the seafloor, where the mining system operates, picking up raw materials from the seafloor, producing disturbance or destruction and tailings from mining, the separation and washing of nodules, and the feeding of the nodules into the hoisting pipe. (Figure 5);
- the water column, through which the collected raw materials are transported either in packages (buckets) or in pipes, which may break and release their contents into the water column; and
- the sea surface, where the mining vessel is positioned and to which the raw materials are delivered, and which will separate the raw materials from waste materials also producing tailings which are released somewhere.

The following are the basic considerations for building an environmentally-friendly manganese nodule mining system and mitigating the above mentioned three impacts:

#### ***Leave as much sediment on the seafloor as possible***

A CLB system will dig up nodules together with the sediment beneath the bucket tracks. The deep sea soil will be washed up to the ship, and will surely become the main pollutant as it is spread by the currents into the marine environment. From an environmental point of view, the CLB system is not a proper choice for commercial mining operations.

Most environmental assessments assumed that the soft, top-layer will be completely removed by the collector and some of the soil will be transmitted together with the nodules to the surface ship. In order to put the least amount of sediment into the water column, both at the ocean surface and at the intermediate

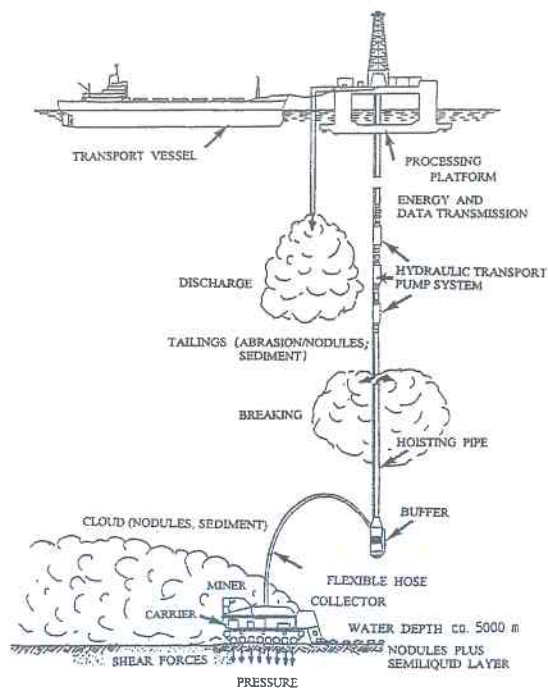

Figure 5 - Environmental Impact Factors

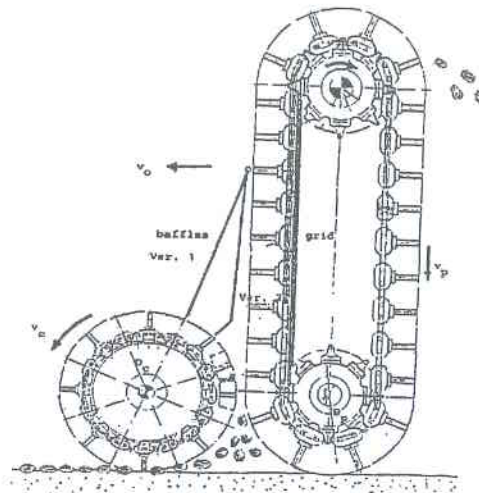

Fig.6 Hybrid Collector

Figure 6 - Hybrid Collector

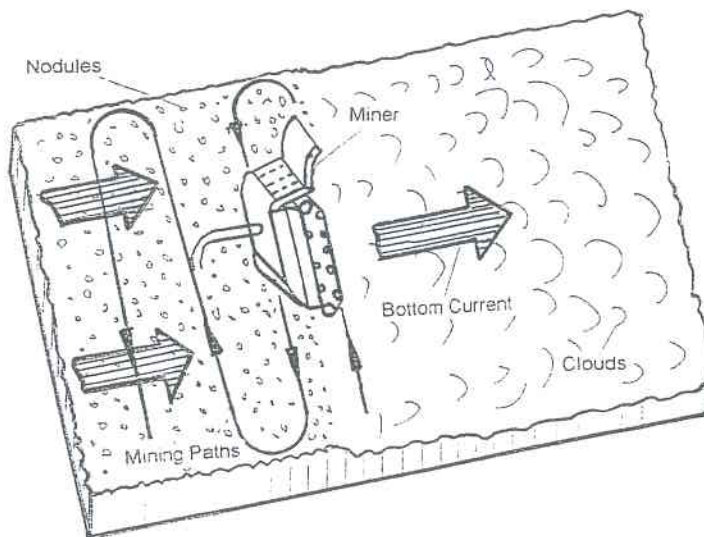

Figure 7 - Programming of Miner Path

buffer zone, the miner should separate the soil from the nodules near the sea floor and leave sediments at the sea bottom. A good, skillful design of a separation device may achieve the goal. A hybrid principled nodule collector might be one of the examples. (Figure 6)

#### *Lowering the sediment plume height*

Sediment will be stirred up by the water jets and the movement of the collector and be dispersed into the abyssal hydrosphere; therefore, sediment plume will be formed after the collector. This re-suspended material is regarded to be responsible for lethal effects to the benthos and to abyssal life. The initial height of the plume blown up by the miner will be one of the decisive factors in the spreading range of the plume. The plume will drift away down the current stream while resettling to the ocean floor according to its own settling velocity. The settling velocity is a natural factor of the sediment itself. To limit the range of the sediment plume blanketing area the height of the plume needs to be minimized.

#### *Best programming of miner paths according to the topography and deep sea current*

The design of the mining site is also a factor that influences the blanketing of sediment re-deposition. From an engineering point of view, the pattern which the miner scribes on the sea floor is expected to be regular (possibly rectangular) in order to optimize, as much as possible, the efficiency of the mining operation. If the topography in the mining site permits, the paths of the miner should be perpendicular to the direction of water current (Figure 7). The mining approach should progressively go against the water current so that re-suspended sediment can only drift and resettle in the already mined area and not bury the nodules area, leaving comparatively clear surroundings to the miner for its next path. Therefore the sediment re-deposition area will always remain in the area disturbed by the nodule collector, with only little amounts of re-suspended soil resettling in the areas beyond the mining site. The results are that the soil in the post-mined area will be turned upside down and mixed with the sediment drifted upstream by the water current, without destroying so much of the un-mined area therefore causing little environmental impact to other areas.

Moreover, in order to keep the nodule collector moving on the planned track, an *in situ* control system should be applied. A towed collector will lead to random tracks on the sea floor. The environmental impact on the sea floor by a towed collector will be much higher than by a self-propelled collector.

*Nodules collector weight should be as light as possible so as not to sink to the bottom*

In most engineering concepts the pick-up mechanism is mounted in front of the carrier. The carrier moves on the seafloor where the nodules and the semi-liquid top-layer have already been removed.

The carrier system will directly compress, squeeze, disrupt or shear the sub-layer. As the supporting system of the carrier moreover will have to interlock in the layer in order to provide the necessary propulsion and/or the assistance for a secure and safe maneuvering, the pressure of the carrier on the ocean floor determines the depth of the supporting system in the deepsea soil. Under conditions of safe maneuverability, the weight of the miner should be as light as possible, or the width of the runners or chains should be as wide as possible so as to save the benthos beneath the track.

Laboratory tests showed that the Archimedean screw principle self-propelled miner had a tendency to dig down to the sediment if a hard obstacle is in front of it, while the caterpillar principle self-propelled miner could overcome the obstacle if a proper design of stress was incorporated.

*Preventing lifting pipe jam thus no discharge of nodules from the pipe line*

When the hoisting system fails due to the pipe being jammed by big-sized manganese nodules or even due to some unknown reasons, the contents of the lifting pipe have to be released into the water column, which will immediately interrupt the operation of the lifting system. This mixture of deep-sea water, manganese nodules, fines from nodules abrasion and of sediment particles will cause an impact on the immediate environment. The tailings from such a pumping system failure will in any case, be very small compared to those produced by the miner. Such problems may be prevented by choosing appropriate pumping equipment and keeping the hoisting systems in good operating condition.

*Discharge of waste water from the mining vessel to a specified depth*

Discharges of transport or processing waste water at the sea surface is regarded as harmful to the environment, primarily from the danger of darkening the upper layer of the sea and thus effecting the photic zone and the primary bio-production. It has been proposed, therefore, to discharge the effluent at least below the photic zone, i.e. at water depths of more than 1,000 m. The possibility of discharging all effluents directly down to the seafloor has been considered. This would require a loop system with a lifting pipe from the seafloor to the sea surface and a discharge pipe from the sea surface to the seafloor.

Technically, there will be no difficulty to develop such a loop system. It would only cost money. This measure will transfer the problem of tailings from the sea surface to the sea floor. It will also result in a situation where not only the miner tailings will be created but also tailings from the discharge of the transport and processing water. Nevertheless it seems to be a less harmful solution than the discharge of tailings at the sea surface.

### *Preventing oil leakage*

Any leakage of oil from the mining vessel, transportation cargo vessel or from the mining system will be harmful to the ocean environment. Although the leakage is no worse than a break down of an oil transportation tank, we should also take it into consideration when designing the system.

### *Principle of effective use of natural resources*

A nodule rich area must be cleanly mined to provide for both short term and long term economic operations. If fifty percent of nodules are recovered within the width of the nodule collector then the area may remain uneconomic for mining in the future. To maintain a high recovery rate of manganese nodules, the following factors for designing a mining system must be assured.

### *Good pick-up efficiency within the width of the nodule collector*

A CLB system may have the advantage that all sizes of nodules collected can be conveyed to the mining vessel without crushing them into small pieces. But it is considered inadequate for commercial operations because of its deficiency in the control of the buckets on the ocean floor, which leads to a very low efficiency of nodule recovery.

A pick-up rate of 90% or more within the collector width would constitute an important technical and environmental design principle. The collector width should be at least as wide as the width of the carrier. Sea and laboratory test results show that a mechanical principle collecting system (Figure 8), a hydraulic (COANDA) principle collecting system (Figure 9) and hybrid principle collecting system (Figure 10), if their designs are good enough, could meet the objective mentioned above.

### *In-situ control is also a main design guideline of a deep seabed nodule collector*

A passive towed system has the same disadvantage of lack of control as a CLB system. During the first ocean mining tests, towed vehicles were used.



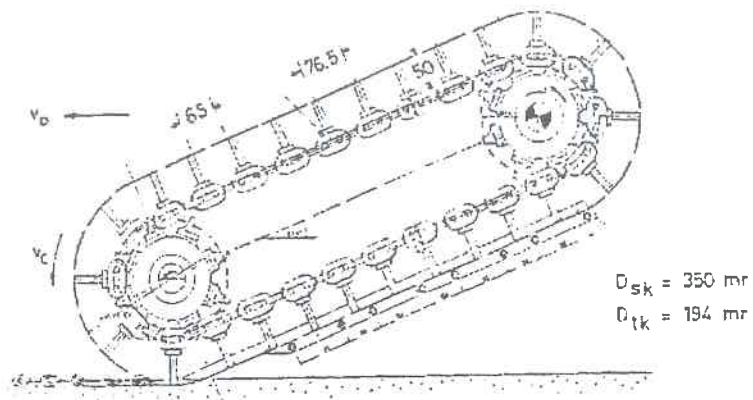

Figure 8 - An Example of Mechanical Collector

### Principle

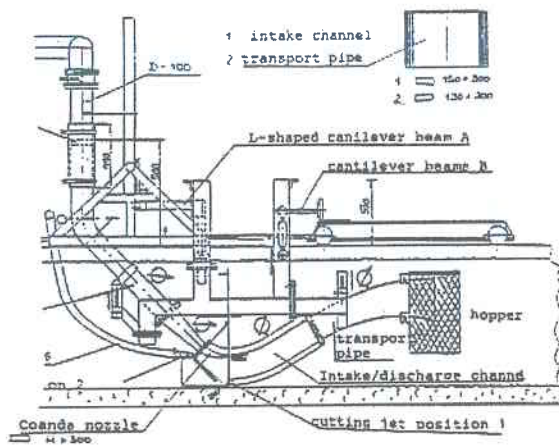

Figure 9 - Collector of Coanda Nozzle

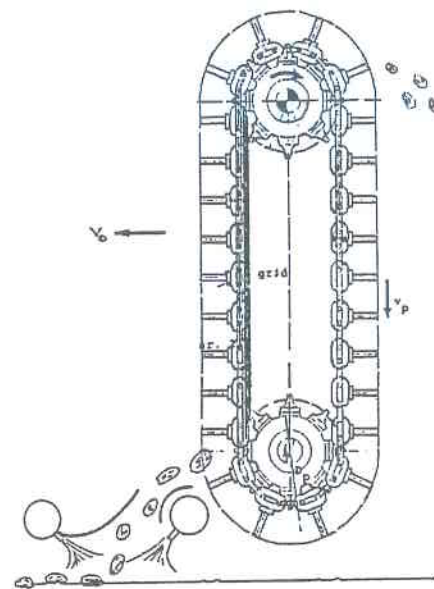

Figure 10 - Hybrid Collector

These sledge-type vehicles moved on lateral skids. This was sufficient for the first feasibility tests of pick-up principles. An application of the towed collector to commercial mining does not seem appropriate under the principle of effective use of natural resources. Towed vehicles cannot be maneuvered precisely, neither horizontally nor vertically. This would result in random tracks on the sea floor with a high rate of sea floor disturbance and less efficient nodule pick-up. A constant forward speed cannot be achieved with a towed collector and, hence, no constant and controllable pick-up rate will be possible. Control of the sediment plume will be even more difficult.

Good maneuverability of the nodule collector means less overlapping of mined areas and less gaps between collector tracks, which in turn means the high efficiency of mining production and also high recovery rate of the resources. Therefore, a self-propelled vehicle is highly recommended. Technically and environmentally the best method is a caterpillar carrier, which provides high load bearing and traction forces on the very soft soils. Caterpillar chains destroy the sea floor less than alternative traction method such as the Archimedean screw, which apparently works but destroys the deep sea floor to a considerable extent. Moreover, all motions of the caterpillar crawler such as acceleration, stopping, curves and slip can be controlled by *in situ* microprocessor.

### **High Reliability of the Whole System**

Other technical principles require high levels of reliability and availability on the deep sea floor, easy maintenance and repair. Components of the system should be as simple as possible. Transferring as many as possible industrial-proven technologies from other industries should also be a guideline in designing a deep-seabed mining system. For example, the collector should consume as little energy as possible. Mechanically, the collector should be simple, rugged, flexible and yet very light.

### **MODEL MINING SYSTEM DEVELOPED BY COMRA**

When China started its national project of manganese nodules exploration and exploitation in 1991, researchers working on mining technology tried to verify published results from pre-pilot mining tests during the period of 1970 to 1982, and tested new ideas such as rubber crawler, various collectors and clear water lifting, etc. Therefore Changsha Research Institute of Mining & Metallurgy (CRIMM) and Changsha Institute of Mining Research (CIMR) built two laboratories. Both laboratories can be used to carry out nodule collecting tests and lifting tests. As the first approach, all of these research institutes have prepared China to be ready for the development of whole mining system.

In the most recent Five-Year Plan (from 1996 to 2000), a group of experts, called the chief designer group, was formed under the administration and coordination of COMRA. This group includes a chief designer, a co-chief designer, a mechanical specialist, a hydraulic transportation specialist, an electric and electronic specialist and a naval architect. They are responsible for technical decision making and coordination of the development of the whole mining system (Figure 11), which is being developed based on all the considerations of main principles of designing a deep seabed mining system, that consists of a surface vessel, a pipe-string, a flexible hose and a miner.

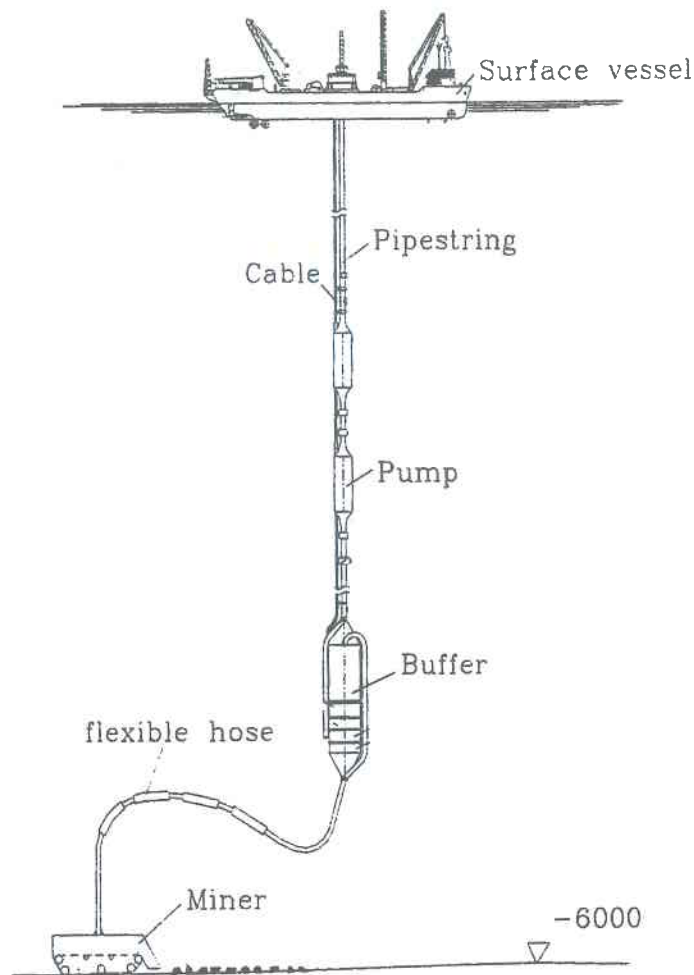

Figure 11 - Model Mining System by COMRA

During the Ninth Five-Year Plan (from 1996 to 2000), research activities will concentrate on special technology for collecting and lifting nodules, for example,

- **High efficient collector:** to reduce power consumption with high pick up rate, to minimize the disturbance to the seafloor based on CRIMM collector and existing collectors.

The hydraulic-principle hybrid collector (Figure 12) was developed based on the experience of former research after a lot of test runs. It overcomes the disadvantages of the pure hydraulic collector (Figure 9) and comprises a pick-up device, double jets and baffle plates, Coanda nozzle and transporting channel, an outlet with a grid for the separation of sediments and nodules. It is simple in structure, reliable in working with only one power unit, high pick up rate, and low sediment content.

This collector was tested with sediment imitation of 3kPa in shear strength and artificial nodules of sizes between 15 and 75 mm in diameter. Furthermore, it was mounted on a self-propelled carrier and tested on sediment imitation.

The pick up rate of the collector reached nearly 100 percent, content of sediment was less than 1.27 percent and production rate was 9 tons per hour. Operating conditions were miner width of 0.6 meter, speed at 0.6 meter per second, abundance of wet artificial nodules of 7 kg per square meter, and shear strength of sediment imitation less than 5kPa.

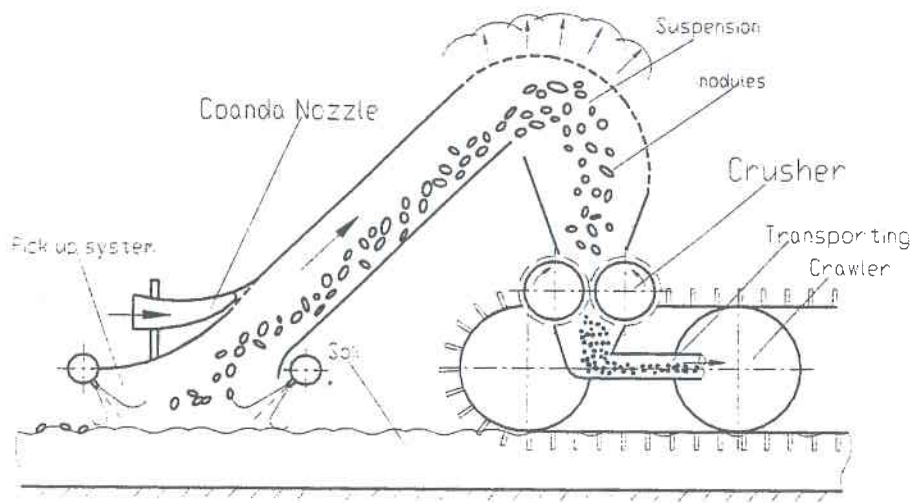

Figure 12 - CRIMM's Hybrid Collector

- **Carrier:** to design and test a seabed tractor with high traction for moving on extremely soft soil properly based on crawler developed by CIMR.

A self-propelled crawler consists of a caterpillar tread, a driving wheel, a guide wheel, a support wheel, a frame and power supply. The difficulties with developing a self-propelled crawler as support and propulsion for the collector are: (a) the crawler has to move on extremely soft soil with low footprint and to produce high traction force, (b) the grousers of the crawler should not destroy sediments too much to protect creatures living in the top layer, and (c) the crawler should be reliable and have good maneuverability.

The caterpillar tread is composed of rubber with high involute grousers. The advantages of this caterpillar tread are that it is simple, light weight, and is good at self-cleaning. Deep sea sediments transit from the semi-liquid layer to the consolidated layer. This transition area can be as thick as 15 to 30cm. The grouser should be high enough to dig into the sediment to provide sufficient traction. Because of thixotropy of the top layer of sediment, disturbance to the sediment should be minimized. So the involute grouser is one of choice. The wedge grouser is under discussion because of the traction requirement.

The crawler is driven by a hydraulic system. The hydraulic system includes one hydraulic pump with submersible electric motor, one auxiliary pump, valves pack for two caterpillar treads, one motor for the crusher, and a hydraulic cylinder for the collector's movement up and down. The miner can move forward and backward, turn, and brake easily.

- **Parameter study of hydraulic lifting:** to deal thoroughly with hydraulic lifting, to investigate equipment, and to carry out evaluation of possible environmental consequences in the lifting process.

The lifting installation, 30 m in height and 100 mm in inner-diameter of a pipe, consists of a lift subsystem, a pressure stabilization subsystem, a water-supply and discharge subsystem, an air-compressed subsystem, and a computer supervisory and data processing subsystem (Figure 13). The system can perform the various lift tests only by altering the lift system and the system of the power source, rather than its main system. In addition, it can be designed to be an inclined or warped lift pipe according to the requirements of research work.

On this system, tests were carried out using two types of jet pumps; i.e. concentrated jet pump and circular jet pump. Thorough experiments were conducted for their dimensions, installed height, jet flow rate, inlet and outlet pressure, sucked jet flow rate, slurry concentration and lift capacity, obtaining a large quantity of data, which can be used as the basis for designing the jet pumping system.

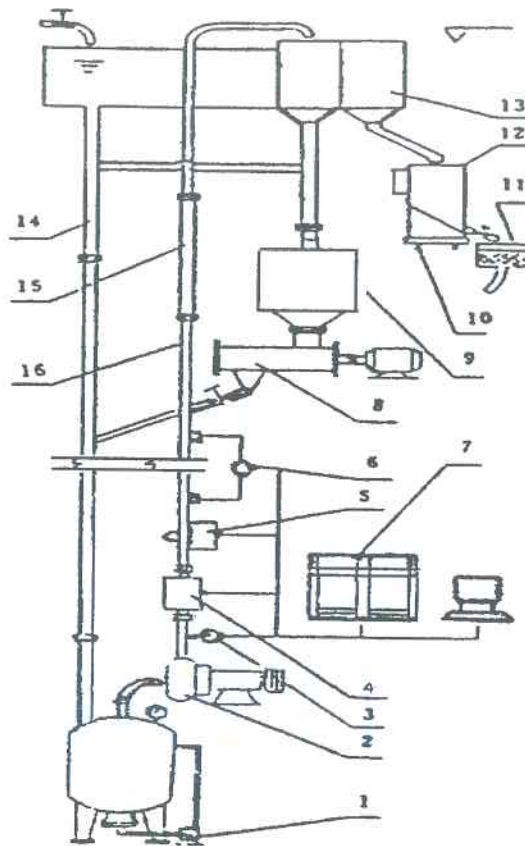

Figure 13 - The Lifting System of Slurry Pump

1-pipe pump 2-slurry pump 3-pressure sensor 4-flow meter 5-densimeter 6-pressure differential transducer 7-control panel 8-nodule feeder 9-storage tank 10-electronic weighing system 11-sampling tank 12-calibrating tank 13-distributing

Slurry pumping is the main type of hydraulic lift. It has the advantage of simple technology, high lift efficiency and reliable operation. Research work was conducted on the physical properties, chemical and mineral composition, and in obtaining full information, including nodules, morphology, internal structure, element occurrence, chemical composition, and physical and mechanical parameters.

Tests were carried out on settling velocity of nodules in static water and the floating velocity of grouped nodules, and to obtain the hydraulic parameters of nodules. High-speed photograph of lifting velocity of nodule particles in the lifting process was taken and measurement of minimum lifting velocity and lifting velocity field in the pipe was made, laying a foundation for the study of the hydraulic lift mechanism of nodules.

In addition, tests were completed of lift parameters for 4 groups of simulated volume concentrations, such as 5%, 10%, 15% and 20%. With the cooperation of InterOceanMetal Joint Organization (IOM), CRIMM conducted the experimental study of lift parameters and pulverization characteristics for 3 groups of volume concentrations, such as 5%, 10% and 15% using natural polymetallic nodules supplied by IOM and sea water by Guangzhou Ocean Geology Survey. The tests resulted in a large number of important information.

From sample analysis, we have reached the fluctuation law of size composition of nodule particles after the slurry had been pumped 10-80 times and travels 600-4800 m, we have established the slime content of the lift overflow for deep-sea mining at the depth of 5000 m equivalent, providing the scientific basis for tailing processing and environmental evaluation.

CRIMM has completed the experimental study of airlift technology and parameters. Tests were carried out on lift parameters for 4 volume concentrations of nodules, at 3%, 5%, 8% and 12% at 3 air injected depths. In these tests, the volume concentrations went beyond the scope of volume concentrations tested ever in indoor experiments, the completeness and regularity of test data have come up to advanced world standard. Test results, included air-injected quantity, water-lifted volume, nodule-lifted quantity, static-pressure distribution of three-phase flow in a pipe, optimum flow pattern and efficiency of three-phase flow lift and unit energy consumption for lifting. Equations for calculating parameters concerned were derived, thus filling the gaps in research on air-lift techniques in China's deep sea mining programme.

- **Flexible hose transportation:** Flexible hose connects vertical pipestring and miner as a buffer element. Its shape transporting capability determines how to develop the whole system. This is a key technique in lifting.
- **Integration of measuring and controlling system:** The main task for such a system is to integrate the newest electronic technology and power transmission into the deep-sea mining system, except for special transducers only in deep sea mining system.

The telemetry and remote-control system for the collector consists of a controller, an underwater measurement and control unit, power and communication cable and a monitoring station. Its basic operating principle includes:

- applying a communication network consisting of a multi-station PLCs and a personal computer to achieve remote-control and parameter measurement of underwater traveling and nodule collection by the collector;

- applying modern intercomputer communications and CRT display techniques to achieve the centralized monitoring and management of the nodule collection process by the collector.

The system has the advantages of powerful functions flexible configuration, convenient modification of the control and measurement schemes, and high ratio between performance and price due to its application of distributed control structure, rational configuration of the hardware and software and correct overall design scheme.

Bi-directional transmission of all measured and controlled information can be achieved through a single communication cable between the control ground station for measurement and control and the local station in the miner, realizing the remote control of the hydraulic collector. The tests conducted more than 70 times show that the system is characterized by convenient manipulation, reliable operation and anti-interference. The monitoring station has the advantage of rich pictures, convenient configuration, and good man-machine interface, ability to achieve real time collection and storage of process data and produce historical trend graphs and data report forms convenient to analyze the test results. Also, the system serves the function of long distance configuration and debugging of local and master station of PLC. Self-developed gravity inclinometers, rational speed sensor for caterpillar chain, depth sensor and azimuth sensor can operate reliably.

## **COMRA'S EFFORTS FOR A FUTURE MINING SYSTEM**

As mentioned above, COMRA will finish its design of the whole mining system in the year 2000. One of the topics currently under discussion is that some parts of the mining system will be tested in a lake in Yunan Province, that is the Lake Test. The research and development of the mining technology will follow one test after another after the year 2000.

### **Lake Test**

COMRA plans to integrate the seafloor system to mine artificial nodules in the lake, which is 150 meters in depth, in 2001. The seafloor system consists of a crawler, a collector, a crusher, a flexible hose, and the surface vessel. Artificial nodules will be paved on top of the sediments, which have nearly the same geotechnical properties as that of the Chinese claim area. The tests will focus on the maneuverability of the miner, the pick-up rate of the collector, and the control of the integrated system.



Together with the integrated mining test in the lake, an environmental assessment of the impacts from the simulated mining test, as a portion of our planned NaVaBa project, will also be carried out. It is the best opportunity to do the environmental-simulation analysis with the real lake test. Therefore, sediment properties in the lake will be compared with that of the deepsea sediment, the bio-baseline will be obtained prior to the mining test, and monitoring of the sediment plume produced by the miner will also be conducted.

### **Sea Trial**

Based on the success of the Lake test, sea trials of the whole system will not be omitted. The water depth may go down step by step from 1000 meters to 6000 meters but the testing mining system should be scaled in the same way as that of a pilot mining tested. When commercial mining can be foreseen, integrated systems for mining nodules should also be expected to be tested in the mine site.

Together with the sea trials of the mining system, comprehensive environmental assessment programmes should be carried out.

With the development of computer-aided design, the methodology has changed very much and has advanced. Traditional design methods cannot meet requirements for today's technology development. Changing ways of thinking shall result in changing style of working. At the same time, offshore petroleum operations influences deep sea mining more and more with its proved technology. For example, dynamics simulation for slim pipe in water can be used to calculate dynamic parameters of the lifting pipe.

Virtual reality techniques can make the whole mining system operate utilizing the computer. Geometry and structure defined by CAD are inputted to the Dynamic simulation. The Dynamic simulation feeds back to CAD design. Finally, animation techniques enable scenarios to be made on a computer of the mining system. With this technique we can test the mining system as often as required. US navy feasibility investigation for mobile offshore base (MOB) is a good example to use such a technique.

When commercial mining will occur is not clear up to now. It is reasonable for us to design and test the mining system in virtual reality, aided with one or two parts development. With this simulation-based design we can predict accurately, reduce costs and shorten cycle time.

When commercial mining is imminent, the physical scale model will still be used to validate the design before fabrication begins.

## INTERNATIONAL COOPERATION – COST-EFFECTIVE WAY TO ACHIEVE THE COMMON GOAL

### Features of Deep-Seabed Mining at Current Stage

The situation has changed a lot since the United Nations Convention on the Law of the Sea that was signed in 1982. A document prepared in 1981 by the US Government's National Oceanic and Atmospheric Administration (NOAA) announced that manganese nodule mining could be divided into three generations between 1988 and about 2040. The first generation involves the initial consortia, that is Kennecott, OMA, OMCO, OMI who were to start mining between 1988 and 1995. Eighteen years have passed since their prediction. The nodules are still lying on the deep seabed.

The features of deep seabed mining have also changed very much and now we are aware of the following aspects:

- A universal acceptable agreement for deep-seabed mining has been set up so that entities that are willing to undertake the deep-seabed mining must obey uniform rules and regulations.
- Deep seabed mining is unlikely to take place in the near future. Economically, it is not as optimistic as earlier thought.
- Its competitiveness with land-based mining is rather minimal at this stage when commercial mining is expected in the distant future.
- The high risk of failure remains as it was.
- Technology development is very demanding in terms of multi-disciplinary efforts and financial inputs.
- Environmental impacts from deep-seabed mining are universal issues and have become the concern of more and more people.
- The principle of the "Common Heritage of Mankind" requires that people from all over the world endeavor for common exploitation and the utilization of the resources.

The above features represent an ideal case for international cooperation for technology development, in all the areas in general and mining in particular.

## Technology Development through International Cooperation

Due to its high cost and risk of failure, deep seabed mining technology should be developed and tested in cooperation with other countries that are also interested in the field. Almost every one believes that it is an ideal case for entering into cooperation for technology development, however, many think that such cooperation is difficult to establish even when commercial operations are seen as being far away in the future and no competition is in view, which leaves a large role for the International Seabed Authority (ISA) to play.

It is clear that one of the Authority's task is to promote international coordination of the exploitation of the resources in the Area. The ISA could play a very important role in bringing different countries and different disciplines together.

As mentioned above, COMRA is developing its own mining technology and very ardently wishes to find partners in the field. COMRA, from the very beginning when it was formed, has been making unremitting efforts for international cooperation. We think the best way to acquire the available knowledge, the techniques and experience is to coordinate the research and development programme internationally. A well-organized programme can avoid repetitive work and be cost effective. The possible subjects for international cooperation and coordination might be as follows:

- joint design of the mining system;
- manufacturing different components of the system in different countries with intensive coordination;
- assembling and testing the system jointly with all the partners; and
- sharing the results and experiences among all the alliances.

## CONCLUSIONS

As consciousness of environmental protection progresses and develops, COMRA puts more and more effort into environmental considerations when designing its mining system. Environmental protection has become a common awareness among engineers and researchers and a common guideline for designing the mining system. Based on these environmentally-friendly considerations, COMRA has developed a model mining system. Laboratory tests have been carried out during the last several years. COMRA and its engineers are engaged in developing a one-tenth scale pilot mining system for the lake test, which will include

tests of the concept of the mining system, technology and equipment, and assessments of the impact from simulated mining.

Development of the mining technology means large investments, a long gestation period and also a high risk of failure. International cooperation will be a cost-effective way to achieve the common goal. COMRA welcomes any countries and entities to join our ongoing programme and is conducting the international cooperative programmes in developing the mining technology with several other organizations, such as Germany and IOM. COMRA is also willing to join the technology development programmes of other countries in the way mentioned above in the paper.

## REFERENCES:

- Amman, H. (1991) 'Soft Ocean Mining', Offshore Technology Conference, May 1991, Houston, Texas, USA.
- Amann, H. (1994) 'Basic Engineering and New Technologies for an Environmentally Acceptable Deep Seabed Collector.' International Advisory Conference on Deep Seabed Mining Policy, Sept. 5-6, 1994, Seoul, Korea.
- Alexandrov, I. L. et al 1992 '100 Inventive Solutions for Deep-Sea Mining.'
- Jin, J. C. and Zhou, N. (1996): 'Basic Results and Prospects for COMRA's Activities in the Area'. International Seminar on Deep Seabed Mining Technology, Oct. 18-20, 1996, Beijing, China.
- Liu, F. (1995) 'China's Program in Marine Resources Development'. Offshore Technology Conference, May 1-4, 1995, Houston, Texas, USA.
- Liu, F. (1997) 'NaVaBa – A New Initiative of COMRA's Environmental Program'. Proceedings of International Symposium on Environmental Studies for Deep-Sea Mining, Nov. 20-21, 1997. Tokyo, Japan.
- Liu, F. et al. (1997) 'Basic Research on Characteristics of Deep-Sea Sediment Clouds Produced by Marine Mining'. Proceedings of International Symposium on Environmental Studies for Deep-Sea Mining, Nov. 20-21, 1997. Tokyo, Japan.
- NOAA (1981) 'Deep Seabed Mining: Final Programmatic Environmental Impacts Statement (PEIS)'. (Vol. 1 and Vol. 2), NOAA/OOME, Washington, D.C., USA.
- Oebius, H.U (1997) 'Deep-Sea Mining and its Environmental Consequences', Publication of Technical University Berlin, Germany.
- Thiel, H. et al. (1995) 'The German Environmental Impact Research for Manganese Nodule Mining in the SE Pacific Ocean'. Proceedings of the ISOPE – Ocean Mining Symposium, Nov, 21-22, 1995, Tsukuba, Japan.
- Trueblood, D. et al. (1997) 'The Benthic Impact Experiment: A Study of the Ecological Impacts of Deep Seabed Mining on Abyssal Benthic Communities'. Proceedings of the ISOPE, May 25-30, 1997, Honolulu, USA.
- Welling, C. (1996) 'Manganese Nodule Design Concept. International Seminar on Deep Seabed Mining, Oct. 18-20, 1996, Beijing, China.
- Yang, N. et al (1997) 'New Era for China Manganese Nodules Mining – Summary of Last Five Years'. Research Activities and Prospective. Proceedings of the ISOPE, Nov., 1997, Seoul, Korea.
- Zhou, H. Y. (1997) 'Chinese Environmental Investigation Related to Potential Impact of Deep-Sea Mining'. Proceedings of the International Offshore and Polar Engineering Conference, May 25-30, 1997, Honolulu, USA.

## Summary of the presentation and discussions on an environmentally-friendly deep seabed mining system

An Environmentally-Friendly, Deep-Seabed Mining System presently under development by COMRA and discussed by Mr. Feng Liu and Mr. Ning Yang is defined as a system that will not produce serious harm to the marine environment, with the same objectives as the "soft" mining system introduced by Professor Schwarz. The workshop was informed that COMRA considered four major systems that had been conceived, or tested, in the last thirty years; the continuous line bucket (CLB), the passive towed collector, the active self-propelled collector and the submarine shuttle. The ideal system sought by COMRA needs to be environmentally friendly, efficient in utilization of the natural resources, and highly reliable in operation.

The principal impacts identified were seabed disturbance by the miner, spillage due to a vertical transport riser pipe failure, and discharge of surface tailings. These potential impacts lead to design principles based on the pickup and transport of clean nodules without sediment, the fastest possible bottom plume settling rate to minimize burial of adjacent nodules, and the selection of optimal miner tracks based on topography and currents to carry the plume away from unworked ground.

The weight of the collector should be minimized to prevent it sinking into the soft sediment, pipe size should be such to prevent jamming and waste water should be discharged at a depth least likely to create negative impacts. Other design criteria include an optimum collector width and high-pickup efficiency. The system should be reliable and use as many industrially-proven technologies as feasible.

COMRA has developed two collector types, a hybrid collector, and a hydraulic collector, both on caterpillar tracks, one with a mechanical and the other with a water jet pickup using a Coanda nozzle. A flexible hose between the connector and a buffer on the main lift was considered critical. No field tests have yet been carried out but are planned. COMRA's positive views on technology development through international cooperation were detailed and are discussed in Part IV.

Mr. Feng Liu responded to a number of questions regarding benthic impacts, economics of the system, design parameters and the dispersal of tailings plumes.

## **Benthic impact experiments**

Asked if COMRA was going to carry out a separate benthic impact experiment, the speaker said that COMRA did not have any concrete plans for that in the near future and did not consider the so-called disturber (or disc harrow) experiment to be a good example of the real mining system as its impact would be somewhat different. Perhaps, later, COMRA would conduct the experiment along with the sea trials of the mining system and that would be closer to the real impact.

## **Economic limits**

The speaker was asked if there were economic limitations for the system being developed, like a production cost of \$50, \$100, or \$150 per tonne? In response Mr. Liu indicated that it would be hard to evaluate the economic aspects as the system was only to one-tenth scale. It was his opinion that COMRA should place more and more emphasis on the environmental aspects because many solutions could easily be excluded in the beginning if they were shown to be too costly.

## **Design limits**

Regarding his emphasis on keeping the weight of the system as low as possible, Mr. Liu said that while the main task of the mining system was to mine the nodules, he felt, that in designing the system, consideration should be given to keeping the environmental impacts as small as possible. He was asked, how COMRA defined limits for the equipment, for the technology and for the mining area? How did COMRA choose the equipment technology in relation to the damage on the sea floor or in the water column? In response, Mr. Liu said it was very difficult to provide these definitions at this stage, especially the economic aspects, because the metal markets are constantly changing and the technology is developing very fast. COMRA did not know when it would start commercial mining but was aware of the problems.

## **Environmental aspects**

A participant had a question about the planning of the miner's path that showed, in the figure presented, a current flowing in only one direction whereas in the actual situation there would be a circulation of the bottom currents. Sedimentation would occur on both sides of the track. One side might be less impacted than the other because of the current vector. Mr. Liu agreed that there would indeed be no clear water, just relatively clear water.

Asked about the environmental aspects of the exploitation of nodules, the impacts on marine life and the integration of experts in marine biology in the environmental impact studies, the speaker explained that their NaVaBa programme, the Natural Variability of the Baseline was divided into correspondingly different phases, including the physical baseline, the biologic baseline and oceanographic baseline.

### **Tailings and plumes**

The speaker was asked what would be done to decrease the discharge of the tailings from the platform on the surface. The discharge would have fine particles of both sediment and nodules that could be discharged in the water column perhaps 1000 m below the surface, but how could the effects of this discharge be reduced? Mr. Liu answered that they had simulated it in the test facility. Nodules were circulated in the 30 m high, closed loop for an equivalent distance of about 6000 m. The results of a joint testing by COMRA and IOM were available on request. Other hydraulic tests to aggregate the fine sediment had been completed. Aggregated particles sink faster than single grains, which take a long time to settle and may be transported over large distances. These experiments were done with their German colleagues in VWS in the laboratory using an artificial plume to measure the speed of the downward stream. The results were published in Liu, et al., (1997)





## Chapter 10

### SCIENTIFIC AND TECHNOLOGICAL RESEARCH AND DEVELOPMENT RELATED TO DEEP SEABED MINING

*Mr. Guy Herrouin  
Director of the Centre in Toulon, IFREMER  
Centre de Toulon La Seyne  
LaSeyne, France*

**Synopsis**

**Historical Background**

**Extensive Technical Feasibility and Economic Studies**

**Impact of Deep-Seabed Mining on the Environment**

**Generic Studies on Deep Sea Technologies and Deep Sea Environment**

**Summary**

## SYNOPSIS

In France, the nodule mining story started some thirty years ago. A lot of work has been carried out over this period and our way of thinking how to manage this activity has undergone several changes since the beginning. It is now time to present the main results, as well as our ideas today in this matter, together with future perspectives that could be considered.

AFERNOD/IFREMER was one of the first four pioneers registered.

A very important exploration program was accomplished from 1970 by AFERNOD/CNEXO, then AFERNOD/IFREMER. The important results obtained during the exploration phase enabled us to submit an application to be a registered pioneer investor on 17th of December 1987, once having solved the overlaps with the other consortia. Besides, the feasibility study of an industrial exploitation was based on the knowledge of the characteristics of the mining area : topography, soil characteristics, abundance of nodules, etc.

The technical and economic studies of an industrial exploitation was developed during the five years (84-89) taking into account all the aspects : complete mining system, transportation, processing, cost evaluation and metal prices. These studies were lead by an engineering team of IFREMER and specialists in different areas and with the assistance of subcontractors such as : offshore oil engineering companies, IFP (French Petroleum Institute), metal processing companies, etc. Experiments have taken place in the fields of processing of nodules, locomotion, nodule harvesting, physical processing of nodule slurry (crushing in water, dewatering,...), hydraulic lifting.

A fruitful cooperation with German colleagues (companies and institutes) was developed on some key points of the mining system during these years. The profitability evaluation of a commercial exploitation of a 1.5 Mt/year production capacity was positive but marginal. In addition, the costs of development, including a pilot mining and processing facility, appeared relatively high and too expensive for a private investor.

Then, in the late 80s, the perspective of a commercial operation seemed feasible only on a long-term basis.

This is the reason why we decided, at that time, to lead generic research and development (R&D) in deep-sea technologies and to follow, actively, the development of deep-oil, offshore technology.

Ten years later we made substantial progress in deep-sea technologies through scientific research, and the recent ultra-deep, off-shore oil technology confirms our basic design.

However, at that time, these results were not technically mature to enable us to undertake the important and costly, pilot, mining operation. In addition, metal prices appeared relatively low to consider a profitable venture at the time.

In conclusion, our policy is to continue to follow the development of generic R&D (science and technology) in deep sea. At the same time we examined other potential deep-sea minerals because there was a common experience in this field.

## **HISTORICAL BACKGROUND**

AFERNOD ("Association Française d'Etude et de Recherche des Nodules océaniques"), IFREMER, CEA (Commissariat à l'Energie Atomique) and MET-ALEUROP have centralized all the work done as well as results obtained on poly-metallic nodule deposits since 1970.

At the end of 1998 the total of updated expenses was around one billion French Francs ( $\approx$ 150 M Euros).

IFREMER is managing the French Programme as the depository of the French government for nodule deposit studies.

### **Exploration**

From 1970 to mid-1986, 42 cruises were conducted over a period of 1,200 days at sea. A total of 5,500 samples of nodules and associated sediments were collected using free-fall grabs and box corers or core-barrels attached to a cable. On those samples 45,000 chemical analyses were performed. More than 120,000 photographs of the sea bottom were taken with cameras attached either to the free-fall grabs, to the deep-towed fish RAIE or to the unmanned submersible EPAULARD (fig.1).

The topography of the sea bottom was mapped by conventional echo sounders and after 1980 by the multi-beam echo sounder "Sea Beam" which was equipped on the O/V Jean Charcot, owned by IFREMER.

A deep-towed, high resolution, side-scan sonar named SAR, was especially designed and built to map the detailed sea-bed topography (features less than 50 cm wide).

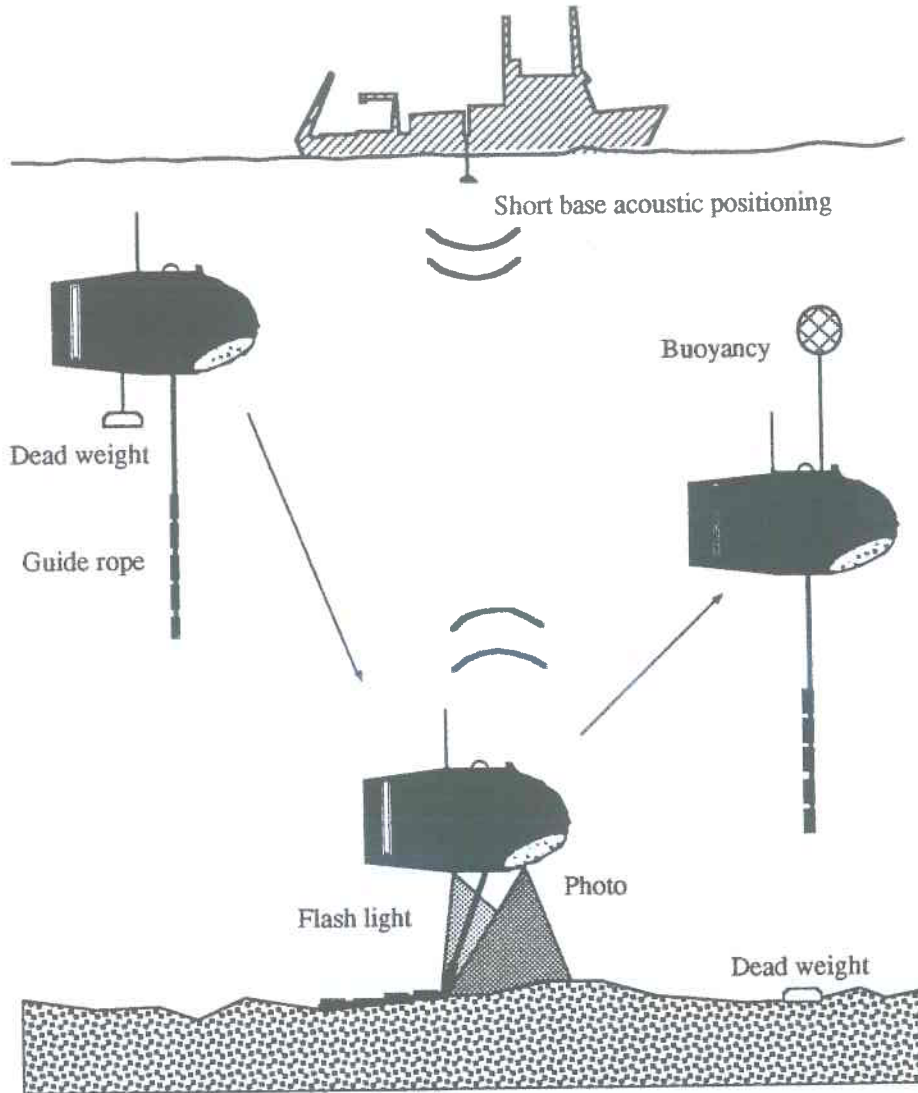

Figure 1 - Epaulard

This equipment was successfully operated during a 70-day cruise of the O/V Jean Charcot in April-June 1986 in AFERNOD's favorite area in the Pacific.

Air water-gun seismic surveys, 3.5 kHz mud penetrator surveys and magnetic surveys have been performed to study the relationships between the occurrence of the nodules and the structures of the sediment cover and its volcanic basement.

Current-meters, temperature and salinity gauges, buoys for long-term measurements of waves, winds and other meteorological features have been deployed to study the physical environment of deep-sea mining, from the surface to the bottom of the ocean.

Undisturbed samples of sediment were collected for soil mechanics studies. Satellite recordings were acquired and studied to determine the probability of occurrence of hurricanes and tropical storms.

Throughout those surveys, biological observations were made to serve as a basis for studies of the possible impact on the environment of future deep-sea mining operations. From all the data acquired during exploration, AFERNOD's geologists outlined a synthetic description of a prospective deep sea nodule deposit for the mining engineers.

They provided metallurgists with mineralogical and chemical analyses and representative samples for processing studies.



Figure 2 - NAUTILUS 6,000 m.

In December 1988, 16 dives of the NAUTILE (fig. 2), the manned submersible owned by IFREMER, brought geologists and engineers 5,000 meters deep to survey the bottom and perform special experiments. Those dives confirmed the previously outlined scenery and emphasized the delineation of the nodule fields by the detailed topography.

### **Status of Mining Rights**

The applications of the three pioneer applicants (France, Japan, USSR), were registered on December 17, 1987 in New York. IFREMER, on behalf of AFERNOD was allocated a 75,000 square kilometers pioneer area, of which 43,960 sq.Km was part of the application filed by AFERNOD in July 1982.

### **Mining**

From 1972 to 1976, AFERNOD participated in research on the continuous line bucket system (CLB).

During the same period, other mining concepts were also scrutinized. In 1979, after the discovery of many major obstacles on the sea bottom such as vertical cliffs more than 10 m high and large pot-holes capable of holding the biggest draglines, it was obvious that the main problem was to achieve an efficient driving and control mechanism for the bottom collector.

In 1980, we studied a free shuttle mining concept. In this system it was proposed to use free unmanned submersibles to gather nodules on the seabed and lift them to the surface. However, it appeared that the system could not be used to mine the nodules economically for several decades.

The programme was then reoriented to a hydraulic lifting system with a motorized collector, able to be driven on the bottom with sufficient freedom from the 5,000 m pipe string. This program was implemented from 1984 to 1989.

A vehicle, known as PLA 2-6000 (fig. 3), was designed and built to test the use of Archimedes screws for travelling on the soft bottom sediment, and a collecting device to harvest nodules.

The PLA 2 was delivered in December 1985 and performed a series of deep-water dives in October 1987 in the Mediterranean Sea demonstrating its capabilities of dynamic flight, landing and moving around on the sea bottom, and finally take-off to surface.

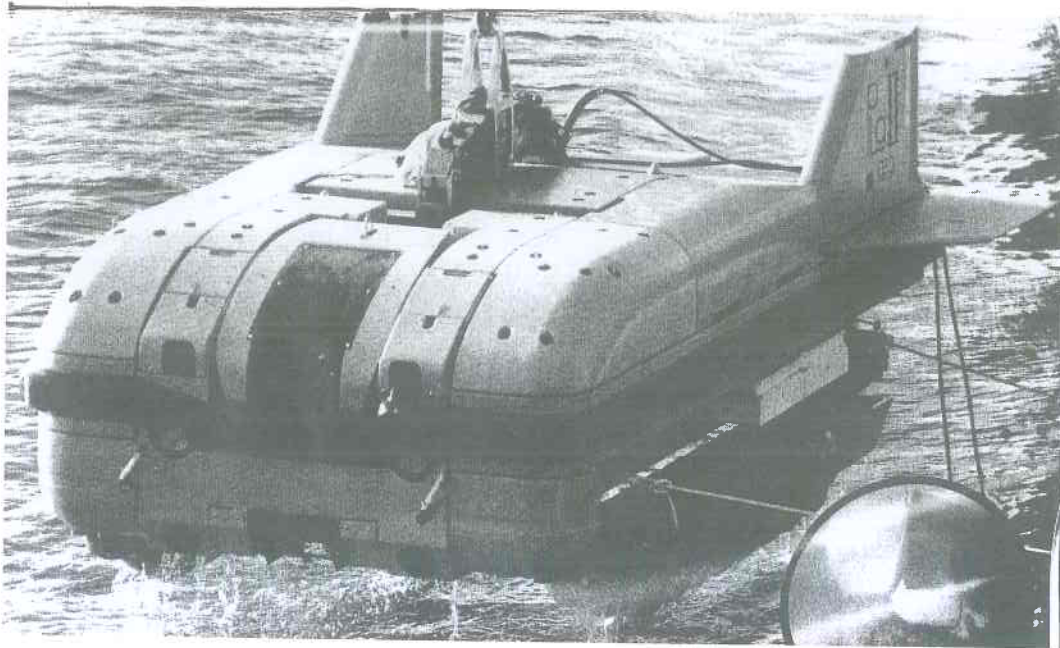

Figure 3 - PLA 2-6000

### **Processing**

A pilot plant was built in the Fontenay-aux-Roses' CEA facilities to treat a continuous flow of 5 kg/h of nodules by ammonia leach. The same pilot plant was later transformed to process nodules by sulphuric acid leach under pressure and moderate temperature.

Further research has been directed to recover manganese, either by smelting or acid leach. A small smelting test made by MINEMET RECHERCHE, a subsidiary of MetalEurop, gave excellent results on the recovery of all metals with a low energy consumption. The recovery of cobalt by acid leach was greatly improved by the presence of  $Mn^{++}$ , during the last pilot test made by the CEA.

### **EXTENSIVE TECHNICAL FEASIBILITY AND ECONOMIC STUDIES**

These studies were conducted during the period 1984-1989 in order to have a complete overview of the perspective of nodule exploitation, particularly with the purpose of obtaining the allocation of a 75,000 sq/Kms pioneer area.

In order to meet the objectives of the programme, technical studies were carried out concurrently with environmental data analyses and economic studies.



The interaction between environment, dredging strategy and technical definition was always borne in mind. The annual production capacity and the basic exploitation scenario were chosen then, combining the various factors in order to reach a final conclusion on the profitability of an actual operation.

The engineering of metallurgical processing had been studied extensively, based on the adaptation and optimization of existing hydrometallurgical and pyrometallurgical processes for terrestrial nickel and manganese ores. The study program on the mining aspects presents innovative technical points.

### **Basis of the Studies**

The basic assumptions were as follows :

- The mining zone would be the IFREMER/AFERNOD pioneer area.
- The nominal annual capacity would be 1.5 Mt of dry nodules delivered to the processing plant. This figure was left open to discussion ; 350,000-t, 750,000-t and 3-Mt capacities would also be examined.
- Four metals would be extracted from the nodules : manganese, nickel, copper and cobalt.
- The exploitation strategy would be optimized, the aim being to mine a high rate of nodules from the dredged seabed. This optimisation would also limit the area mined and consequently diminish the perturbation on the environment.

Taking into account topographic characteristics, we chose a hydraulic recovery system based on a self-propelled miner.

Experiments have taken place, generally, on a small scale, in fields such as the physical processing of nodules in the water, locomotion and nodule harvesting.

The cruises of the O/V Jean Charcot during April to June 1986, in the North Pacific, were based on the use of the deep-towed side-scan sonar " SAR " (6,000 m) and its high-resolution mud penetrator. The distribution of obstacles that, until now, had been observed only from isolated photographs, was mapped. These maps and sediment cross sections helped to choose the targets for diving with the manned submersible NAUTILE (6,000 m), that were done in November-December 1988 during the cruise NIXONAUT.

The dives confirmed the synthesis conceived from the many previous data to reconstitute the bottom scenery where the nodule fields are present.

In the areas selected for future deep sea mining, the nodules are uniformly laying on a rather flat bottom except for nearby obstacles, such as cliffs, subsided troughs, outcrops of old indurated sediments and soft sediment flats that show as "grey stains" on sonar displays.

The cliffs, several decameters high, extend horizontally over several hundred meters and continue as steep slopes, along the edges of major crests. They are in direct relation faults that affect both the sediment cover and the basaltic basement.

Pot-holes or troughs are mainly located on the highs and are obviously erosion structures cutting the sediment layers. Some of them extend more than one kilometer in diameter and 60 m deep into the underlying basalt.

Other obstacles observed are channel-like structures without nodules at the bottom of the valleys and volcanic seamounts several kilometers wide and cresting a thousand meters above the bottom.

Soil mechanics studies were completed by *in situ* shear strength measurements using a specially designed scissometer (vane test) operated from the NAUTILE.

Observations and measurements were also carried out on the breaking strength of the nodules and collecting factors. The presence of those major or minor obstacles on the ocean floor considerably reduces the accessibility of the nodule deposits, at least for the first generation of mining systems. During the first period of deep-sea mining, only selected areas will be visited by the harvesters. Those areas are scattered within the entanglement of crests edged by cliffs and pot-holes, valleys with winding channels and volcanic seamounts.

A sea state and meteorologic buoy and a current meter line were launched in the AFERNOD site for several months and the swell and wind data were cross-checked using an operational model.

These results have been used to make geostatistical simulations of the mining field.

### *Conclusion*

These studies have been as extensive as possible and they form a reliable basis for performance predictions and the estimation of mining costs. The choice of production capacity is obviously very important.

Considering the number of operational days on site, time lost in maneuvering, and losses incurred during dredging, raising and transfer of nodules to the processing plant, is it possible to design and operate the system so as to reach the fixed production target of 1.5 Mt/yr over a period long enough to make investments profitable?

In order to determine the number of operational days on site, it is necessary to take into account dry dock time, transit, changing ore-carriers, weather conditions, programmed maintenance periods and unforeseen breakdowns. Studies carried out in cooperation with experienced operators have led to a figure of 115 days lost per year. The system therefore would be effectively operational 250 days of the year.

A simulation of the mining process carried out on the French mining field led to the conclusion that the self-propelled system with a 15-m wide collector, moving at a speed of 0.65 m/s and working on the best fields of the French pioneer area, is capable of supplying the processing plant with 1.5 Mt/yr of nodules over a period of 50 yr. In this way, 30 % of the nodules occurring in the area would be recovered. The remaining 70 % would be broken down into 12.5 % due to losses, 16 % owing to topography and 41 % left in areas that could be exploited by a second-generation system.

### **Mining System**

One of the basic principles in the system design has been to resort to the use of technology to be developed in the next years. These studies were supported by experience acquired in the following areas :

- Offshore, with the assistance of the French Institute of Petroleum (IFP) and in particular with reference to the deep sea drilling program. Several engineering companies from this sector participated in the programme.
- Mining and, more especially, the physical processing of ore, as well as the construction of the first ocean mining equipment able to operate in shallow water.
- Deep-sea exploration, where France plays a leading role through IFREMER research and projects entrusted to industrialists in this sector.

Other areas of study included dredging, coal transport, and marine engineering. Moreover, IFREMER and German companies (PREUSSAG-THETIS) and Institutes (KARLSRUHE, BERLIN, SIEGEN,...) have worked in cooperation on the study of some key components of the mining system, namely:

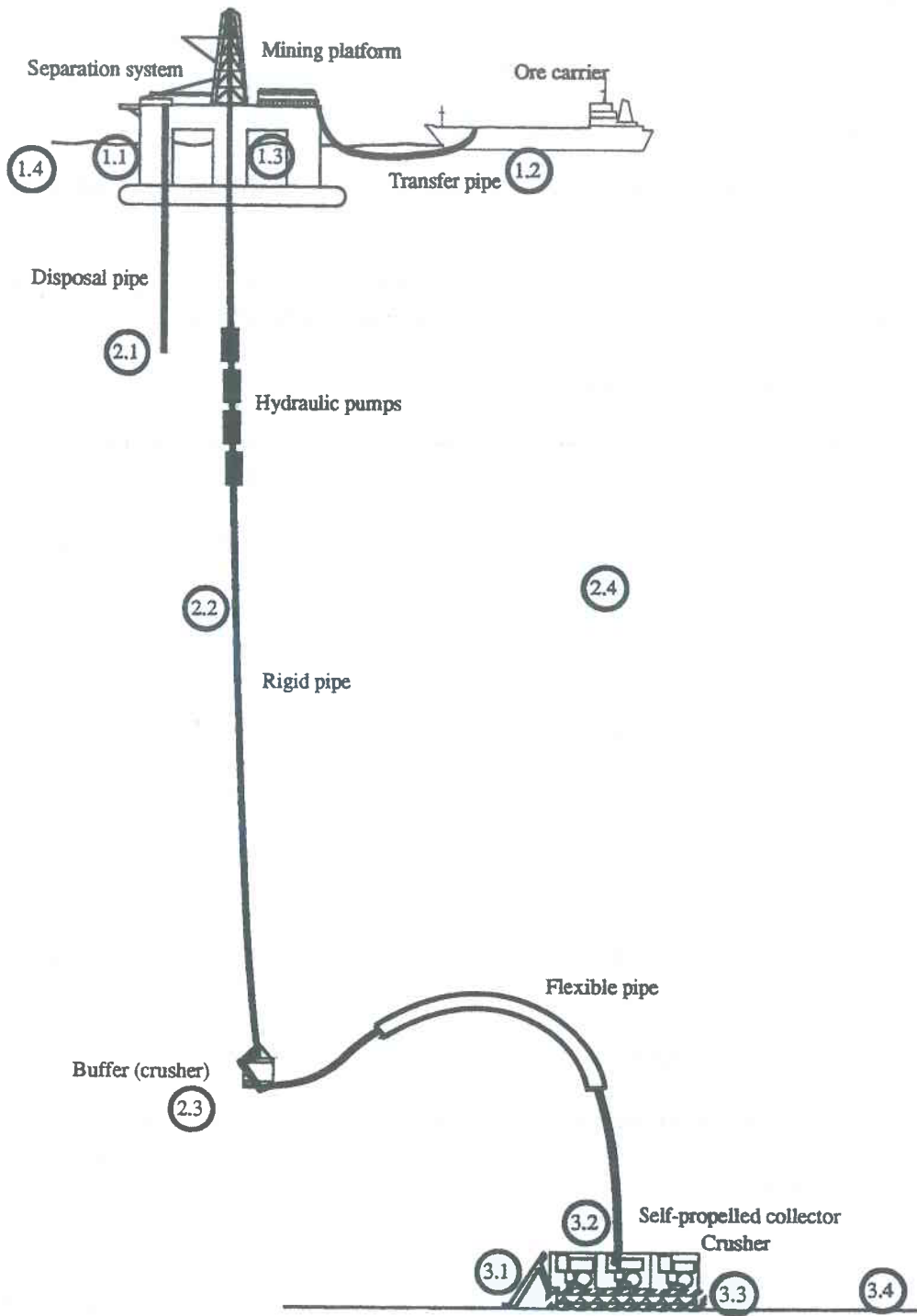

Figure 4 - Mining System

- Pick-up device
- Locomotion of miner
- Hydraulic lifting of nodules.

This cooperation allowed a more thorough study of these important technical aspects.

Finally, modern project management methods were used for planning, parametric estimation of costs, and operational research, among others.

### *General functioning of the system*

The maximum yield of the system is 500t/hr (140 Kg of wet nodules per second). The nominal displacement speed of the system is 0.65 m/sec.

Obstacles to dredging are considered routine when their width does not exceed 150 m.

### *The miner*

The miner fulfills three main functions : nodule collecting, locomotion and the entire process of conditioning and pumping the nodules before they are sent up through the flexible pipe.

Detailed studies of the miner's functions have led to the choice of the miner's basic equipment, its design and preliminary dimensioning of the assembly (fig. 4).

The miner measures 18 x 15 x 5 m. Its gross weight is 330 t, and its apparent weight is 78 t.

### *The hydraulic pumping system*

This fundamental function was the object of extensive studies and tests. Three different systems were thoroughly studied : the air-lift, the centrifugal pumps and the pulp system.

### *The flexible hose*

The 600-m long flexible hose connects the miner to the main pipestring. The structure is made of a type of light Coflexip. The inside diameter is 381 mm.

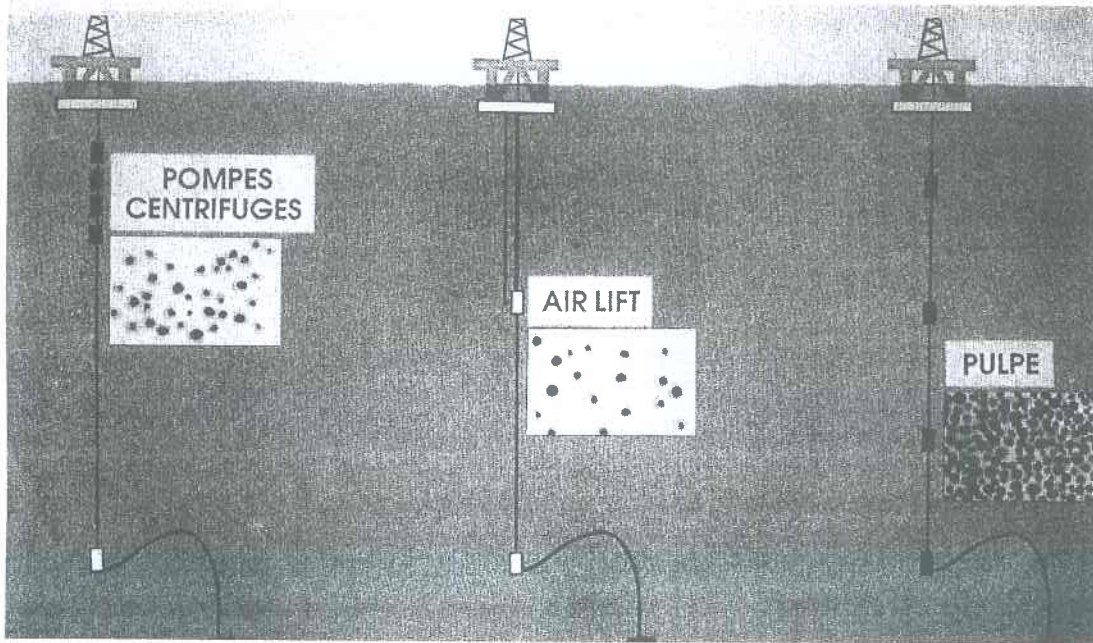

Different pumping concepts

### *The buffer*

This is the interface between the flexible hose and the pipestring. It consists of the joint and connecting point of the flexible pipe, an intermediate flexible hose, and sensors, sonar equipment and other devices.

### *The pipestring*

Following comparative and dimensional studies, a steel pipestring with a high yield strength was chosen. The outside diameter of the pipestring is 406 mm ; this is the standard dimension for oil risers. The tubes are in 27-m-long joints ; these sections are equipped with riser-type connectors to assure quick connection (clip Riser patented by IFP). The weight of the pipestring is reduced by flotation over the first 2000 m.

### *Mining vessel*

From an economic viewpoint, the surface support vessel is a major investment in the mining system.

A comparative analysis of different types of support vessels and functional studies led to the choice of a semi-submersible catamaran platform. In size and design, it looks like a large drilling platform.

The draft project for the semi-submersible platform overall length, 110 m ; displacement in transit, 28,600 t; displacement in operation, 41,600 t.

### **Transport**

The nodules are to be carried from the mining area to the processing plant by means of nine specialized Panamax ore carriers.

### **Metallurgical Processing**

Processing studies were undertaken in France by CEA for hydrometallurgy and by Minemet Recherche (METALEUROP) for pyrometallurgy.

#### *Polymetallurgical process*

The pyrometallurgical process to obtain concentrates of nickel, cobalt and copper from nodules is derived from the process used by SLN for garnierite nickel ore at the Doniambo plan in New Caledonia.

#### *Hydrometallurgical process*

The hydrometallurgical process was greatly improved through work involving the dissolution of nickel, cobalt and copper.

### **Economic Studies**

A complete economic study was performed with the help of several specialized subcontractors. An exploitation planning model has been built to evaluate annual expenses and revenues.

#### *Exploitation costs*

Total engineering investment amounts to \$940 million (6385 millions FF), and operating costs amount to \$240 million per year (1640 millions FF per year), divided as follows :

The average annual cost of interest on investment, taking a 1/2 equity ratio (60 % capital stock and 50 % ten-year loans) would be \$75 million per year. The average annual cost of exploitation (operating costs and investment costs) over 21 years of production is estimated at \$315 million (2160 millions FF), or \$220 (1660 FF) per metric ton of dry nodules.

### *Impact on metal market*

Exploitation at 1.5 Mt/yr would produce the following quantities :

Nickel.....	19,730 t/yr as metal
Copper.....	17,810 t/yr as metal
Cobalt.....	3,525 t/yr as chloride
Manganese.....	382,500 t/yr in ferro silicomanganese alloy having an 80 % manganese content.

Considering the quantities of these metals produced, imported, consumed and exported in France and in the EU, a production of 1.5 Mt/year could be absorbed by the markets in these countries.

### *Metal prices*

The market prices used are respectively : nickel, \$8/Kg (\$3.60/1b) ; copper, \$2.10/Kg (\$0.95/1b) ; cobalt, \$15/kg (\$6.80/1b) ; manganese, \$0.65/Kg in the Fe-Si-Mn form.

These prices are the result of market analyses of each metal (econometric approach, limit price, previous average price). The revenues generated by the sales of these metals is \$496 million per year (3375 millions FF per year), i.e. \$330/t (or 2260 FF/t) for dry nodules.

### *Profitability evaluation*

A profitability analysis was carried out involving a calculation of the annual cash flow based on the schedule of expenses and revenues. The annual cash flows, after tax, have been evaluated in order to compute the internal rate of return.

The internal rate of return that characterizes the specific interest of the project has been evaluated at 12 % regardless of the source of financing used. Taking a 1/2 equity ratio (60 % capital stock and 50 % ten-year loans) the profit rate on capital stock would be 14 %. The investment pay-off period would be six years from the moment production is operating at full capacity, that is, 12 years after the decision to invest.

*Note : These figures are in the economic context of the late 1980s.*



## IMPACT OF DEEP SEABED MINING ON THE ENVIRONMENT

### Principle

This aspect is obviously very important and we took it into account in the mining strategy and in the design of the mining system.

First, and this is the heart of the problem, our system is a **very selective** one. It means that we do not damage large areas by losing nodules that would be buried into the sediment and thus lost for further collection by any other system. Besides, the use of a guided collector enables us to collect only in areas where nodules are abundant, which would not be possible with a towed collector.

Second, the collector does not penetrate too far into the sediment in order not to disturb it more than a minimum.

Third, for discharged water, we expect to discharge a limited amount of sediment deep in the column, or even not to discharge at all, if the " pulp system " could be used. However, for the time being, we are not sure that such a system could be completely practicable.

### Figures of Impact <sup>1</sup>

#### *Areas to be mined*

It is obvious that the topography will command the mining strategy.

We did a mapping of two correlated factors, abundance and slope, by geo-statistical simulation. On this map, we simulate the tracks of a motorized collector with hydraulic lifting (Chautru J.M. et al., 1987). We determined that the mineable fields (averaging more than 15 kg/m<sup>2</sup> and flat) cover only 30 % of the bottom. They appear to be around 5-25 km long and 1-5 km wide, averaging 50 km<sup>2</sup>. These mining fields will be separated from one another by several kilometers (Fig.1). Each site will be mined only for a few months. However, the mining system can be moved from one site to the other within a couple of hours.

The major investment of a mining system will be the mining platform and its 5-km lifting pipe. It must be made profitable by a maximum recovery of nodules. As the bottom collector cannot be larger than approximately 15 m and cannot move at more than 0.65 m/s (1.2 knots) the amount of nodules collected, for a 15kg/m<sup>2</sup> abundance is :

---

<sup>1</sup> These figures come from a report on "evaluation of existing knowledge on deep sea mining and some considerations on its potential environmental impacts" an international study of three partners: Yuzhumorgeologiya, Preussag/Thetis, Ifremer/Afernod - May 1992 - writer Jean-Pierre Lenoble

$$15 \text{ m} \times 0.65 \text{ m/s} \times 15 \text{ kg/m}^2 = 146.25 \text{ kg/s}$$

With a 20 % loss, the flow arriving to the surface ship is :

$$146.25 * 0.8 = 117 \text{ kg/s}$$

$$\text{i.e. } 117 \text{ kg/s} \times 3600 \text{ s/h} / 1000 = 421 \text{ t/h or } 10\,000 \text{ wet t/day}$$

For a system working 250 days per year (including maintenance, repairs, careening and bad weather), an additional loss of 10 % during transportation is factored into the plan, the yearly production is :

$$10\,000 \text{ t/d} \times 250 \text{ d/y} \times 0.9 = 2\,250\,000 \text{ wet t/y}$$

and with a 0.7 factor to convert wet to dry nodule weight,

$$2\,250\,000 \text{ t/y} \times 0.7 = 1\,575\,000 \text{ dry t/Y rounded to } 1.5 \text{ dry Mt/y.}$$

The total area mined by a commercial operation, gathering 1.5 million tonnes per year during 20 years, is calculated by :

$$15\text{m} \times 0.65\text{m/s} \times 3600\text{s/h} \times 24\text{h/d} \times 250\text{d/y} \times 20\text{y} / 10^6 \text{ m}^2/\text{km}^2 = 4\,212 \text{ km}^2$$

or by :

$$20\text{y} \times 2.25 \text{ Mt/y} / 0.7 \text{ (loss)} / 15 \text{ kg/m}^2 / 1000 \text{ kg/t} * 10^6 \text{ m}^2/\text{km}^2 = 4\,286 \text{ km}^2$$

These mineable areas will be dispersed in a much larger area, more than three times larger as it will be probably hard to find contiguous prime areas where the mining site density will be 30 %.

The increase of plowed surface will be relatively slow : a hundred square kilometers per year during the first 3 to 5 years, doubling during the five following years, then tripling, etc.

### *Mobilized sediment*

It is in the interest of the miner to reduce, as much as possible, the volume of sediment displaced by the dredge. This volume depends mostly upon the penetration of the collector when gathering the nodules. This penetration can be minimized by using a waterjet device that makes the nodules jump, as designed and tested by the French-German group at the end of the 1980s.

The volume of sediment can be calculated as follows :

- assume a 15m-wide collector moving at 0.65 m/s
- the penetration in the sediment being D (m)
- the abundance of nodules being 15 kg/m<sup>2</sup>.
- the specific gravity of the nodules 2 g/cm<sup>3</sup> or 2 t/m<sup>3</sup>.

The volume of mixed sediment and nodules is:  
 $15\text{m} \times 0.65\text{m/s} \times D$  in  $\text{m}^3/\text{s}$ , i.e.  $0.195\text{m}^3/\text{s}$  for 2cm and  $0.4875\text{m}^3/\text{s}$  for 5cm.

As the nodules are half buried in the sediment, the embedded volume of nodules is :  
 $15\text{m} \times 0.65\text{m/s} \times 15\text{kg}/\text{m}^2 / 1000 (\text{Kg to t}) / 2\text{t}/\text{m}^3 / 2 = 0.0366\text{m}^3/\text{s}$ .

The volume of mobilized sediment is:  
 $V=15\text{m} \times 0.65\text{m/s} \times (D-15\text{Kg}/\text{m}^2/1000(\text{Kg to t}))/2\text{t}/\text{m}^3/2=9.75(D-0.00375)\text{m}^3/\text{s}$   
and per day it will be :

$V=9.75 (D - 0.075) \text{m}^3/\text{s} \times 3600 \text{s}/\text{h} \times 24\text{h}/\text{d} = 842\,400 (D-0.00375) \text{m}^3/\text{d}$   
For 2 cm it is  $13\,442\text{m}^3/\text{d}$  and for 5 cm :  $38\,943\text{m}^3/\text{d}$

With an average specific gravity of the sediment of  $1.4\text{t}/\text{m}^3$ , it is :  
- for a 2 cm penetration :  $19\,155\text{t}/\text{day}$   
for a 5 cm penetration :  $54\,519\text{t}/\text{day}$  respectively.

Note that, during the dives of le NAUTILE, the semi-liquid layer was found to be an aggregate of lumpy, colloidal sediment, on which the nodules are stuck. The waterjet unsticks them and moves only the sediment that is between the nodules, leaving practically untouched the cupules where the nodules were settled. When using a waterjet system the sediment removed could be reduced to the equivalent of the first centimeter only. In this more favorable case, the amount of mobilized sediment should be only  $5\,262\text{m}^3/\text{d}$  or around  $7\,400\text{t}/\text{day}$ .

### *Discharged water*

The hydraulic system needs to use a mixture of water plus nodules and sediment with a volumetric concentration of 20 % of solid. The amount of water is calculated as follows:

- giving a 1.5 dry Mt/y operation (2.25 wet Mt/y)
- 250 days per year of operation
- losses between the platform and the plan 10 %
- specific gravity of the nodules  $2\text{t}/\text{m}^3$ .

The volume of nodules recovered per day is :  
 $2.25\text{Mt}/\text{y} / 250\text{d}/0.9 (\text{loss}) / 2\text{t}/\text{m}^3 = 5000\text{m}^3/\text{D}$  of nodules and the volume of water:  
 $5000\text{m}^3/\text{d} / 0.2 = 25\,000\text{m}^3/\text{d}$  of water.

It has been estimated that the weight ratio of sediment/nodule will not be more than 4 %. Consequently the tonnage of sediment in the discharged water should be:

$2.25\text{Mt}/\text{y} / 250\text{d} / 0.9 (\text{loss}) * 0.04\text{t}/\text{m}^3 = 400\text{t}/\text{d}$  of sediment.

## GENERIC STUDIES ON DEEP-SEA TECHNOLOGIES AND DEEP-SEA ENVIRONMENT

Following our results, obtained from the feasibility studies mentioned above, we have decided to reduce to a minimum level the specific developments while promoting and developing generic R&D in deep sea.

First, we can summarize the critical points for deep-seabed-mining as follows :

### CRITICAL POINTS OF MINING OPERATION

EXPLORATION	<ul style="list-style-type: none"> <li>• Topography</li> <li>• Soil characteristics</li> <li>• Nodule abundance</li> <li>• Meteorological conditions</li> </ul>
EXPLOITATION Miner  Lifting  Surface support  General positioning of the system	<ul style="list-style-type: none"> <li>• Miner specific functions (locomotion, collector, crusher)</li> <li>• Miner positioning</li> <li>• Flexible hose</li> <li>• Pipe</li> <li>• Pumps</li> <li>• Handling system (nominal and emergency conditions)</li> <li>• Storage</li> <li>• Ore transfer at sea</li> </ul>
ENVIRONMENTAL IMPACT	<ul style="list-style-type: none"> <li>• Knowledge of deep sea ecosystem : baseline studies</li> <li>• Water column ecosystem : baseline studies</li> <li>• Consequence of plume of sediment on deep sea ecosystem</li> <li>• Consequence of discharged water on water column ecosystem</li> </ul>

During the last decade there were several achievements which have reduced gaps of some critical points. In addition, projects in progress could improve some aspects of the mining system.

Consequently, as far as IFREMER is concerned, the following are the main points of R&D in deep sea technology during the past few years, and in progress.

<p>ROBOTICS</p> <ul style="list-style-type: none"> <li>- Deep ROV VICTOR 6000 m</li> <li>- Autonomous under-water vehicle : SIRENE</li> </ul>	<ul style="list-style-type: none"> <li>• Teleoperated system</li> <li>• Telemanipulator (CAD)</li> <li>• Long cable : 8000 m (optical, electrical)</li> <li>• Rotating joint (optical)</li> <li>• "Virtual reality representation"</li> </ul> <p>Acoustic teleoperated vehicle with self navigation system, of very high precision (1 m) tested at 2000 m depth.</p>
<p>BENTHIC STATIONS</p>	<ul style="list-style-type: none"> <li>• 6000 m NADIA (Deep sea shuttle for bore hole ODP re-entry)</li> <li>• 6000 m SAMO (Deep sea biological observation)</li> <li>• European project GEOSTAR</li> </ul>
<p>DEEP SEA GEOPHYSICAL SURVEY:</p> <ul style="list-style-type: none"> <li>- SAR</li> <li>- EGR (planned)</li> <li>- Synthetic Aperture Sonar System</li> <li>- Sea floor bathymetry and physical characteristics</li> </ul>	<ul style="list-style-type: none"> <li>• 6000 m side scan sonar, swath = 1,500m</li> <li>• Deep towed geophysical system : <ul style="list-style-type: none"> <li>- high resolution imagery and bathymetry (swath 3000-6000 m)</li> <li>- high resolution seismic : streamer tested and development of seismic source (200 Hz-600 Hz) towed by deep vehicle (6000 m) above sea floor.</li> <li>- subbottom profiler (chirp)</li> <li>- others : doppler, CTD chemical, analysers,...</li> </ul> </li> <li>- high resolution imagery and bathymetry associated with large swath</li> <li>• Research program on sea floor characteristics from data acoustic analysis of multibeam echosounders : development of softwares included in CARAIBES, a general bathymetric software.</li> </ul>
<p>DEEP SEA WRECK INTERVENTION</p>	<ul style="list-style-type: none"> <li>• TITANIC : NAUTILE, ROBIN, Submarine Connectors</li> <li>• Heavy " GRAB " system with drilling pipe : 100 t lifting weight capacity by 6000 m depth.</li> </ul>
<p>POSITIONING</p>	<ul style="list-style-type: none"> <li>• Ultra Short Acoustic Base : POSIDONIA 6000 m, high precision</li> <li>• Hybrid system</li> </ul>

Other potential technologies exist or are in progress, particularly in deep or ultra-deep oil-offshore engineering. Exploitation in this field was started at approximately 1,500 m and will be expected to reach 3,000 m depth and maybe more in the coming years.

Below is shown our involvement in this area :

- IFREMER is actively participating in key studies, such as :
  - Biological environment
  - Sea floor characteristics
  - Meteorological conditions
  - Exploration equipments : seismic, multibeam, sonar, ROV, AUV,...
  - Robotics, materials, hydrodynamics, structures, ...
  
- IFREMER is working in close collaboration with the French Petroleum Institute (IFP) and is well aware of important developments in the various fields, such as :
  - Risers
  - Flexible pipes
  - Multiphase flow pumps
  - Handling systems
  - FPSO

Regarding scientific research, we could summarize equivalent trends in other fields such as environment, geophysics, meteorology, as follows:

SCIENTIFIC	
- Environment	<ul style="list-style-type: none"> <li>• Studies on deep ecosystems using advanced instrumentation</li> <li>• Studies on three main kinds of ecosystems related to different areas :               <ul style="list-style-type: none"> <li>. abyssal : nodules or similar to nodules areas</li> <li>. cold seep : margin, hydrocarbon areas</li> <li>. Hydrothermal sites</li> </ul> </li> <li>• Methodology to study these ecosystems and their reactions to the environmental conditions</li> <li>• Instrumentation and tools :               <ul style="list-style-type: none"> <li>. NAUTILE Submarine and instrumentation</li> <li>. ROV 6000 VICTOR and instrumentation</li> <li>. deep-sea observatories for long-term studies</li> <li>. sets of dedicated equipment and instrumentation</li> <li>. data base, advanced data and image processing.</li> </ul> </li> </ul>

- Geophysics- Geotechnics	<ul style="list-style-type: none"> <li>• Geoacoustic properties of sediment</li> <li>• Slope stability</li> <li>• Sea floor characterisation from acoustic echosounder, particularly multibeam, data analysis</li> </ul>
- Meteorological data	Ocean circulation modelisation

Considering all these results, as well as R&D in progress, we think two conclusions can be drawn.

First, the main assumption we have made on the design of the mining system, is basically confirmed regarding achievements and progress. Thus, acoustics allow a good positioning of the system. Acoustics and seismics will make possible a very efficient exploration of nodule mining areas. It will, of course, be necessary to know all the characteristics (topography, soil characteristics, nodule abundance, etc.) before the mining operation starts in order to be efficient and not to waste time. For this purpose, the equipment required will exist in the next years (around 5-10 years). Vehicles equipped with such sensors could be ROVs or AUVs.

That confirms the capability to mine with a very selective strategy and, as a result, to limit the true mining area, so as to minimize the perturbation on the deep-sea environment.

Meteorological knowledge is becoming better through satellite observation and modelling of the weather in progress through international research programmes and operational oceanography. This is very important for the design and safety of operations at sea.

Concerning the environmental impact we think the methodology and instrumentation have progressed. From this knowledge it will be possible to study the dynamics of the ecosystem within an international programme.

Regarding the engineering side, the deep-oil off-shore technology is in considerable progress. Obviously, it needs some adaptations to deep sea mining. But the experience in risers, handling systems, platforms (eg. FPSOs) will help the designer. We believe our assumptions on the lifting pipe and the flexible hose are confirmed. In future, some improvement might be incorporated in the design of other components such as platforms and ore transfer at sea, for example.

In the coming 5 - 10 years it will be time to upgrade the mining system to take into account this new knowledge if we consider that this could reduce the investment and operational costs. A key question is : will we need a pilot mining operation first on an important scale?

If the answer is yes, we doubt that private investors would agree to make such an investment. If not, it could change the outlook in a more positive way.

Obviously, specific critical points of the system remain, of which the most important are collecting and locomotion. Certainly, it will be necessary to improve the design on these points. However, we think the basic design that has been selected points in the right direction. We do not think it is the right time to invest nor to go any further, particularly because it will be really necessary to test these functions *in situ*, which consequently means, a significant expense.

To conclude, our policy is to promote and develop generic R&D in this field in order to be able to begin deep-sea mining when it is time to do so.



## Summary of the presentation and discussions on scientific and technological research and development related to deep-seabed mining

Work completed and underway in France on Scientific and Technological Research and Development (R&D) related to Deep-Seabed Mining was presented by Mr. Guy Herrouin, of AFERNOD/IFREMER. This group has performed extensive studies to determine the characteristics of nodule mining including exploration, mining feasibility and economics, as well as scientific and technological R&D in the deep sea. Their joint policy is to promote and perform generic research and development in this field and acquire the capability to apply the results to deep-seabed mining operations when the time comes. The two organizations have worked together since 1971, and became registered as a pioneer investor in 1987. They expended more than 1 billion Francs on R&D, joint cruises to study nodules, crusts, sulphides and equipment development. Based on work completed, they concluded that the Continuous line Bucket System, which they tested extensively, was much hampered by rough bottoms, the Archimedes screw was not good, the caterpillar track was much better, slopes greater than 12% were un-mineable and avoidance systems were a necessity. Their general conclusions with regard to nodules indicate that mining operations would be marginally profitable, with a minimum capacity of 1.5 million dry tonnes per year, employing a self-propelled collection device in selected areas of high abundance. The mining, transport and processing operations would need to maintain a high efficiency and would incorporate a buffer with a flexible riser.

The cost of a one-tenth scale, pilot mining operation is too high for a single private investor, Mr Herrouin said. Their future plans include more detailed characterization of the seabed environment and the nodule interface, for such things as the lifting force to pick up nodules; and cooperating closely with other pioneer investors and workers in areas of deep oil technology. Environmental impacts, including those on ecosystems, and caused by natural hazards such as weather and seabed instability, have become critical factors in their planning. From their experience to date, they believe it is more appropriate to study the dynamics of ecosystems rather than to pursue more of the large impact studies (see also Thiel et al, 1997, Ed.).

Prime candidates for adaptive technology from the deep-water petroleum industry, and represented in France by the French Petroleum Institute (IFP), are risers, flexible pipe, multiphase-flow pumps, handling systems, and floating production, storage and offloading vessels (FPSOs).

Considerable discussion followed this presentation, and focused mainly on the proposed metallurgical processing, the economics of the operation, seabed characteristics, and environmental monitoring. Some detailed technical questions were related to the piston pump and to advances in the deep-water petroleum industry.

### **Processing the ores**

It was asked if, in order to reduce the operating cost, it would be possible to use an existing processing plant to improve the return? The speaker did not think so. They had studied the appropriate metallurgical processes and it would not have been feasible to fully utilize an existing processing plant, although he thought it might have been possible to use some part of one. They had looked at the use of the Societe Le Nickel facility in New Caledonia to process 300,000 tonnes per year and which was closed at that time, but the cost of re-starting would have been similar to the cost of building a new system. The amount of money left from revenues would have been insufficient even to pay for an operation using the continuous line bucket system (CLB) which was probably the least costly mining system. IFREMER/AFERNOD concluded that there was no other facility that could be used at that time to process the nodules. It was suggested, however, that the newer higher-temperature, higher-pressure system for processing laterites might be used. Mr. Herrouin explained that there is some difference between the lateritic nickel ores and the nodules due to the presence of manganese in nodules. Mr. Herrouin stated that IFREMER/AFERNOD had found that the manganese could be used to accelerate the reaction with better recovery of nickel than with laterites. Mr. Herrouin pointed out that at the time, the higher-temperature, higher-pressure system was a rather well-advanced system and had been studied by the Commissariat Energie Atomique. He suggested that while there have probably been some improvements since that time, those improvements would not modify the cost of metallurgy significantly.

### **Economics**

The economics of this model gave an internal rate of return (IRR) of about 12%. It was asked if that was for total equity funding or loan financing. The model assumed that 50% of the investment cost was funded at a rate of about 8%. Following on from that question, and looking at the year 1988, it was pointed out that 12% was not much higher than the cost of capital at that time. Bearing in mind that the cost of capital had since been reduced, it was questioned what internal rate of return the speaker believed they should now seek to target including estimates for risk and other factors? A rate of return of 12% in 1988 was a killing rate; at least a 20% rate of return would have been more appropriate. The speaker agreed but it was suggested that if they were running the model now they probably would find

some different problems. The interest rate would be lower now but in between it was also higher so it had been frequently modified. The model system had been run until three years ago but now most of the numbers would have to be reconsidered because of the evolution of technology.

When talking about the mining plan, the variability of nodule density on the seabed was mentioned and it was asked if it was perhaps more complicated than that; for example was the grade of one nodule in terms of nickel, copper, manganese always the same as another nodule say, a km away, or does the grade of the nodules vary and did that have to be taken into account? And even if the grade was the same, did the mineralogy vary, in which case, would the percentage recovery of metals in a marketable form vary from one area to another? Did these factors have to be taken into account in a mining plan or was everything constant? The speaker replied that these did in fact vary. IFREMER even found a relationship between the shape of the nodules and the metal content and from place to place, the metal content varied.

Another participant inquired about the economic parameters of the feasibility studies, such as initial investment, annual production, annual budget, and internal rate of return and hoped also to learn about other parameters such as total reserves, gross revenue, amount of profit and the process of sharing of the profit. It was explained that that was the picture of the problem being modeled but, in fact, by definition, there were no proven ore reserves in the area that could be mined on a commercial basis with a profit. It is anticipated that in the future there will be profits, including sharing some of the benefits with the Authority and perhaps with the country that will host, for instance, the metallurgical plants, because there will certainly be taxes imposed on this operation.

In the feasibility studies some assumptions on the tax system were made, including at that time the system that was in the Law of the Sea. It was also asked how many years the operation would need to continue for such an amount of profit. The studies had been based on a 20 and 25-year operation and the return depended on the assumptions made on the loan, the loan interest rates and so on. The full economic study on nodule mining with different assumptions prepared under the supervision of the European Commission had been donated to the ISA library.

A participant sought clarification on whether there had been any studies done on the total perceived net reserves, and the perceived sustainable years of mining for the whole deep seabed nodule mining system. Mr. Herrouin's response was that to mine the richer part of the French area with a 15 kg per square meter abundance would take between 25 and 50 years.

Considerable discussion followed this presentation, and focused mainly on the proposed metallurgical processing, the economics of the operation, seabed characteristics, and environmental monitoring. Some detailed technical questions were related to the piston pump and to advances in the deep-water petroleum industry.

### **Processing the ores**

It was asked if, in order to reduce the operating cost, it would be possible to use an existing processing plant to improve the return? The speaker did not think so. They had studied the appropriate metallurgical processes and it would not have been feasible to fully utilize an existing processing plant, although he thought it might have been possible to use some part of one. They had looked at the use of the Societe Le Nickel facility in New Caledonia to process 300,000 tonnes per year and which was closed at that time, but the cost of re-starting would have been similar to the cost of building a new system. The amount of money left from revenues would have been insufficient even to pay for an operation using the continuous line bucket system (CLB) which was probably the least costly mining system. IFREMER/AFERNOD concluded that there was no other facility that could be used at that time to process the nodules. It was suggested, however, that the newer higher-temperature, higher-pressure system for processing laterites might be used. Mr. Herrouin explained that there is some difference between the lateritic nickel ores and the nodules due to the presence of manganese in nodules. Mr Herrouin stated that IFREMER/AFERNOD had found that the manganese could be used to accelerate the reaction with better recovery of nickel than with laterites. Mr. Herrouin pointed out that at the time, the higher-temperature, higher-pressure system was a rather well-advanced system and had been studied by the Commissariat Energie Atomique. He suggested that while there have probably been some improvements since that time, those improvements would not modify the cost of metallurgy significantly.

### **Economics**

The economics of this model gave an internal rate of return (IRR) of about 12%. It was asked if that was for total equity funding or loan financing. The model assumed that 50% of the investment cost was funded at a rate of about 8%. Following on from that question, and looking at the year 1988, it was pointed out that 12% was not much higher than the cost of capital at that time. Bearing in mind that the cost of capital had since been reduced, it was questioned what internal rate of return the speaker believed they should now seek to target including estimates for risk and other factors? A rate of return of 12% in 1988 was a killing rate; at least a 20% rate of return would have been more appropriate. The speaker agreed but it was suggested that if they were running the model now they probably would find

some different problems. The interest rate would be lower now but in between it was also higher so it had been frequently modified. The model system had been run until three years ago but now most of the numbers would have to be reconsidered because of the evolution of technology.

When talking about the mining plan, the variability of nodule density on the seabed was mentioned and it was asked if it was perhaps more complicated than that; for example was the grade of one nodule in terms of nickel, copper, manganese always the same as another nodule say, a km away, or does the grade of the nodules vary and did that have to be taken into account? And even if the grade was the same, did the mineralogy vary, in which case, would the percentage recovery of metals in a marketable form vary from one area to another? Did these factors have to be taken into account in a mining plan or was everything constant? The speaker replied that these did in fact vary. IFREMER even found a relationship between the shape of the nodules and the metal content and from place to place, the metal content varied.

Another participant inquired about the economic parameters of the feasibility studies, such as initial investment, annual production, annual budget, and internal rate of return and hoped also to learn about other parameters such as total reserves, gross revenue, amount of profit and the process of sharing of the profit. It was explained that that was the picture of the problem being modeled but, in fact, by definition, there were no proven ore reserves in the area that could be mined on a commercial basis with a profit. It is anticipated that in the future there will be profits, including sharing some of the benefits with the Authority and perhaps with the country that will host, for instance, the metallurgical plants, because there will certainly be taxes imposed on this operation.

In the feasibility studies some assumptions on the tax system were made, including at that time the system that was in the Law of the Sea. It was also asked how many years the operation would need to continue for such an amount of profit. The studies had been based on a 20 and 25-year operation and the return depended on the assumptions made on the loan, the loan interest rates and so on. The full economic study on nodule mining with different assumptions prepared under the supervision of the European Commission had been donated to the ISA library.

A participant sought clarification on whether there had been any studies done on the total perceived net reserves, and the perceived sustainable years of mining for the whole deep seabed nodule mining system. Mr. Herrouin's response was that to mine the richer part of the French area with a 15 kg per square meter abundance would take between 25 and 50 years.

Although the richer area was about 30,000 square km, IFREMER would mine only some part of that. He noted here that extremely little is known about the oceans, and only a very, very small fraction of the seabeds had been mapped. Those areas that have been mapped are sufficient, it was suggested, for hundreds of years so that production would not be expected to decrease once more countries got involved and more partnerships were formed.

Another discussion related to the technological evolution and how it could help the economic aspects. IFREMER was modeling ideas for more selective mining and increasing the average metal content. For example 1% more nickel per ton of raw material would increase the value by \$60 and, therefore, it would be possible to increase the amount of revenue by increasing the average metal content. Would it be possible, it was asked, to do more detailed mapping of these areas to increase the average metal content and be even more selective in the mining process? It was agreed that it would be possible to have such precise data, but in their model IFREMER had assumed a relatively rich area, with high abundance, and good metal content. These assumptions were average, not optimistic but with good abundance and metal content. The speaker was not sure they could expect more than they had assumed.

### **Equipment testing**

A question was asked about the piston pump and if it had been tested in the field, to which the speaker responded affirmatively. He thought it feasible to use it in a single stage. It was ordered from a German company and designed to withstand pressures of 100 bars.

### **Sediment sampling**

Penetration to 30 m for sediment characterization was further discussed. It was necessary to understand the problems of slope stability using better measurements of the soil characteristics, not only on the surface, but at depth. Initial measurements could be made from acoustic or high-resolution seismics and checked by *in situ* testing with a penetrometer to 30 m depth. The Japanese had measured up to 5 or 10 m depth with a piston corer in a geological survey cruise in their nodule area so there are comparative data available. Also mentioned was a list of factors including topography, soil condition, percentage minerals and ocean currents or whatever the meteorological conditions were on the surface. It was confirmed that these were not listed in their order of importance.

## **Seabed characteristics**

In relation to seabed characteristics, Mr. Herrouin noted that when people see a photograph of manganese nodules on the seabed for the first time, they may think of them as a fantastic solution to possible minerals supply problems. When presented with detailed maps, however, it can be seen that the abundance is irregular and the topography is very important. For the person in charge of the vessel at sea, decisions may be determined by the abundance of nodules or on the basis of the topography. This could be important for the decisions to be made during mining operations. Mr. Herrouin emphasized that it is therefore necessary to have very excellent maps of topography, soil characteristics and abundance. With the tools that are now available, such maps can be made, he further stated. With the new side-scan sonars it is possible to map, in one day, a mining site that would be mined for one month. It was agreed that these maps would be important in terms of the information presented on the list and decisions to proceed safely with the operations.

## **The influence of water depth**

A question was asked with regard to the influence, on the deposits, of water depth presumed to be in the range of 5000 to 6000 m depending on the location. Did it influence the metal content or the mineralogy? Were there any major changes with depth? What was the impact of an extra 1000 m on the economics on pumping? Was it a major factor because it doesn't seem to have been mentioned? When different areas were compared was depth of any influence? Are the nodules harder at greater depths? Could these considerations be ignored?

In response, the speaker said that they had designed the system for 5000 m with the possibility of it being 300 m more or less. For nodule areas deeper than that, up to 6000 m, it was indicated by another participant that the depth appeared to affect the quality of the nodule, but in the area they had selected, the water depth did not change much and so the quality of the nodules was similar. The effects of topography that were noted were that in flat areas between the hills, the nodule distribution and variability did not change but close to the so-called cliffs and steeper areas there were either no nodules or nodules of lesser quality. Mr. Herrouin noted that there was probably an effect of this on the geochemistry of the nodules when they were growing. The presence of the cliffs would probably have introduced changes in the sedimentation and perhaps in the geochemistry of the area particularly in a section between the bottom of the cliffs and the top of the abyssal hills, an elevation of approximately a hundred meters. That was the only change that was noted and as those areas had to be avoided anyway because of poor trafficability, there was not really a concern about the difference in the quality of the nodules.

Mr. Herrouin further noted that in the Cook Islands, nickel and cobalt content changed according to depth as well. In some other areas much more variability had been found. In the South Pacific, for example, near the Tuamotu Islands there was much more change from one area to another depending on topography, water depth, and the presence of sedimentation close to the islands. In addition it was discovered that within a given area, there may be small areas with a variety of nodules depending on the type of sediment and this has something to do with the growth history of the nodule. Each nodule type has a different growth history and so a variation in mineralogy. That goes back to the question about the variability of nodules, that water depth can play a role, but in these areas it is not as important.

If you compare larger areas for example, the nodules in the Peru basin, there are high-grade nodules at rather shallow depths of 4000 m and the history of the area in terms of sedimentation is completely different from that in the northern equatorial Pacific. That was confirmed by the French researchers who had evaluated two separate areas, a central one and a western one. In the central area there was not much variability in the topographic features or the characteristics of the sedimentation including the nodules. In the western area, it was completely different. The study of this area was unfortunately stopped too soon. The researchers indicated that they were lucky to keep an area that was rather homogeneous as far as the nodule coverage was concerned. They agreed that in some areas looking at only nodule density could be a deceptive simplification. They stated that looking at recoverable, marketable metal content per square meter, would give a much more complete picture.

### **Sediment characteristics**

It was noted in the illustrations of maneuvering the submersible to collect nodules, that there was a plume of very ultra-fine dust and the suggestion was made that it might be comparable to the metalliferous sediments in the Red Sea that are about minus 2 mm. The speaker acknowledged a similarity and pointed out that when they tested with bentonite in the laboratory tank they could not simulate the sediment conditions *in situ*. They found that even with a lot of water the bentonite was more consistent than the *in situ* sediment.

### **Artificial hazards**

It was pointed out that after 20 years or more of prospecting in this area there had been a lot of objects left on the seabed accidentally and purposefully, and it was asked how this was being dealt with. Was there an assessment of hazardous areas where perhaps the ballast weights from free fall equipment were dumped? A French researcher responded that the ballast weights could be a problem. The ballast



weights used were made of concrete with some steel reinforcement that could cause a lot of damage if it went to a crusher. Some system would be required to prevent them from entering the crusher. With regard to the mining machines that had been left on the bottom, there was no problem as they can be spotted on the sonar.

### **Systems testing**

A question was raised regarding *in situ* testing of the mining systems. Was this perhaps not necessary? Some researchers were proposing to test in shallow lakes, some have done it in 300 m at sea. Is it a key part of the operations or can these things actually be modeled on the computer to get the needed results? It had not been indicated whether it would be necessary to test in 5000 m of water.

In response, Mr. Herrouin indicated it was their belief that it was not the time to experiment more on specific functions. The general development of equipment for science or for the offshore oil industry will provide improved technology, and they would prefer to wait for the expected decreasing costs of applying these improvements to the mining system. At that time they would resume more specific research.

### **Environmental monitoring**

Further questions related to systems for long term environmental monitoring of the seabed and ocean surface. The speaker responded that they had placed meteorological instrumentation and current meters on buoys during the seventies and eighties and acquired considerable data that were compared with the model. They felt that was enough for the moment but others questioned the possible need for more studies on environmental disturbances? The speaker agreed that, as Dr. Liu said before, it would be necessary to reduce the plume and the discharge but first it will be necessary to better understand the fauna on the site.

Different research studies on the deep-sea environments at hydrothermal sites, the arctic area margins, deep offshore oil areas, and abyssal plains, indicate that, in general, the life is very, very poor there. Numbers for this do exist but are not much known. The problem is what priority should be accorded to the fauna in comparison with others factors. It was pointed out that IFREMER had already taken an option by using a miner with six collectors and six crushers, and to discharge all the tailings onto the sea floor and pump only the crushed slurry. The lesser volume would be no doubt more economical for pumping but had the environmental impact been measured on the sea floor? It was explained that by pumping only the slurry there would be no discharge of fine sediment on the surface, only the plume around the miner.

## **Technology development**

The comment was made that it seemed that since 1998 not much had happened in the development of the technology.

In relation specifically to nodule development, the speaker agreed with that perception but did maintain that there was some significant development in scientific equipment and in deep-water oil technology.



## Chapter 11

### JAPAN'S NODULE COLLECTOR TEST ON A SEAMOUNT

*Tetsuo YAMAZAKI*  
*National Institute for Resources and Environment*  
*Tsukuba, Japan*

**Abstract**

**Introduction**

**Japan's Deep-Sea Mining System**

**Ocean Test**

**Nodule Collector Test**

**Post-Mining Observations by ROV**

**Conclusions**

**Aknowledgements**

**References**

**Summary**

## ABSTRACT

A large-scale nodule collector test at sea was conducted in 1997 at the end of a Japanese national R&D project on the manganese nodule mining system. In a high nodule abundance terrace-like area on a seamount, the collector was towed two times by a wire rope from a mother vessel. The amount of nodules collected was 7.25 tons while the actual distance of mining during the two tows was 535 m. Since the population of nodules in the test area was 15.6 kg/m<sup>2</sup> and the pick-up width was 1 m, the collecting efficiency is estimated as 87%.

The collector tracks were observed by a ROV, a side scan sonar, and a towed seafloor observation camera system for the post-mining evaluation. The results are introduced.

*Key Words:* Collector, manganese nodule, ocean test, sea floor observation.

## INTRODUCTION

The self-support ratio of rare metals in Japan is very low and the dependence on imports is 100% for cobalt and 95% for manganese. Hence, the development of manganese-nodule-mining technology is very important for Japan in order to secure a long-term and stable supply of rare metals. Since the early 1970s, therefore, a deep-sea mineral-development programme was adopted as one of the government's principal mining policies in Japan.

The Agency of Industrial Science and Technology (AIST) of the Ministry of International Trade and Industries (MITI) started an R&D project of manganese-nodule-mining technology in 1981 as one of its Industrial Science and Technology Frontier Programmes. The National Institute for Resources and Environment (NIRE), one of AIST's institutes that had studied fundamental technologies for manganese nodule mining, was involved in the project. In addition, the Technology Research Association of Ocean Mineral Resources Mining System (TRAM) was established in 1982 to conduct the R&D of the mining system under the contract with AIST and implemented the study. This program was successfully completed in FY 1997.

## JAPAN'S DEEP-SEA MINING SYSTEM

The manganese nodule mining system developed in Japan is the integration of a seafloor collector system, an ore lifting system, a machinery handling system, and a control and measurement system.

The outline of each subsystem is as follows:

**Seafloor collector system:** Reliability, tractability, safety, and collection efficiency are the most important factors in this system. A tow-sledge-type collector with a pressurized, water-jet-flow collecting mechanism based on the Coanda effect was designed. The larger nodules are crushed in the collector for ore lifting. The collector will be towed by a pipe string composed of a flexible hose and lift pipes, collect nodules with water jet, separate seafloor sediments, crush nodules to a desirable size distribution, and feed them into the ore lifting system.

**Ore lifting system:** Slurry of nodule-water-mixture can be transported by an underwater pump system or an air-lift system through the lift pipes. The vertical nodule-water two-phase and nodule-water-air three-phase flows were studied by NIRE based on a laboratory-size test and a 200 m-deep-tank test. The important factors are the optimum mixture ratio of nodules or nodule pieces in the slurry, the friction factor, wear, and so forth.

The underwater pump system lifts the nodules in two-phase flow with pumps set in series through the lift pipes. Deep submersible pumps, driven by submerged electric motors filled with insulation oil for pressure compensation, were developed, and the pumps were designed to be installed at 1,000 and 2,000 m below the sea surface.

As for the air-lift system, nodules are involved in three-phase flow with air bubbles being released at certain depths of the lift pipes. The air-lift system is considered to be simpler, but would consume more power than the underwater pump system.

For maximizing the efficiency of vertical nodule transport through the lift pipes, such parameters as mining speed, lifting velocity, feeding ratio, and so forth should be controlled. The lift pipes which are made of high-tensile-strength steel have been made as well as a 100-m-long flexible hose made of hard rubber reinforced with steel code.

**Machinery handling system:** Quick deployment and retrieval of the pipes and the collector system, especially prior to and during storms, are very important. The handling system developed includes derrick, lift pipe connecting and disconnecting machinery, lift pipe holders, cable lowering and recovering machinery, and other supporting equipment. The deployment/retrieval speed is primarily dependent on the time required for connection and disconnection of the pipes, the weather, the local seafloor topography, and other conditions. An accurate simulation and monitoring of the pipes' behavior during landing and recovery are necessary for their safe operation. Survival scenarios were also simulated in the developed system.

**Control and measurement system:** The control and measurement system is one of the key features of any deep-sea operation for ocean mining. This system needs advanced technologies in the electronic, acoustic and data processing fields. For the integrated control of the collector and pipe/ship system, many simulations under various weather conditions were carried out. For the mining system, an acoustic measurement device and a hybrid deep-sea cable for data transmission were developed. The cables were composed of three, large-capacity power cables for the pumps, three conductor cables for power supply to instrumentation, and several optical fiber cables for the instrumentation and control signals. The cables were designed to withstand the severest three-dimensional dynamic movements under hard sea conditions.

## OCEAN TEST

At the beginning of the project, it was intended to make a prototype of the manganese nodule mining system based on the results of R&D activities and to verify the mining technologies by carrying out a comprehensive ocean mining test in the final fiscal year of the project. The purpose of the ocean mining test was investigating dynamic behaviour of the total mining system and the mining performance, and to collect data that would be necessary to make the manganese nodule mining system fit for practical use.

In 1995, however, the plan for the comprehensive ocean mining test to be carried out in the final fiscal year was reviewed. The plan was checked over one year from diversified points of view, for example, changes in social backgrounds, the perspective of technologies in the future, cost effectiveness, and so forth. As a result, the original plan for the comprehensive ocean mining test with a fully equipped manganese nodule mining system was changed. The ocean test carried out in 1997 was divided into four experiments to verify selected common elemental technologies that would contribute to the overall ocean development in the future. The most important of the four was a nodule collector test and it is explained in detail in the next section.

### Tests of Handling Lift Pipes at Sea

One of the purposes of this test is to verify the operation and functions of the handling system used for highly efficient, safe, and reliable landing and recovery of underwater equipment including the lift pipes. The others are measurement of stress on the lift pipes under towing conditions, and investigations of the function of a device installed in the lift pipes to prevent pipe vibration caused by Karman's vortex.

For this test, a towed vessel that can be slanted longitudinally or laterally by balancing ballast tanks was used. Some handling equipment such as the derrick, pipe connecting and disconnecting equipment and others were mounted on board. The unit length of lift pipe used in the test was 12 m and the inner diameter 174 mm.

By controlling the slant angles and speed of the vessel, critical working conditions of the test handling equipment were identified. It was verified that the equipment had the expected performance. Then the vibration prevention effect of a helical streak that was installed on the exterior of one lift pipe to restrain the vibration caused by Karman's vortex was examined. Only three pipe units were connected and suspended from the derrick to the water through a hole well of the vessel. The primary vibration occurred at vessel speed of 3.11 knots against the water and the secondary vibration at 4.45 knots in the case of lift pipes without the vibration prevention device. On the other hand, in the case of the lift pipes with the device, the primary vibration occurred at 3.62 knots and the secondary vibration did not occur up to 4.45 knots. Consequently, the vibration prevention effect was confirmed.

#### **Bending Test of Flexible Hose on Land**

The collector is connected with the lift pipes via a flexible hose. For the safe and reliable landing of the collector on the seafloor, the collector should move forward at a certain speed against the water column in order to keep its proper attitude. The relationship between the forward speed and the rolling-down speed is important during the landing of the rear end on the seafloor to the landing of the sledge of the collector. This test investigated conditions for landing the collector on the seafloor so that the bending radius of the flexible hose during this period would be kept greater than 3 m, that is the allowable bending radius. The same one with the nodule collector test was used.

Judging from a rigidity evaluation of the flexible hose before and after the test as well as its following dismantling after the test, it was confirmed that no buckling by the bending occurred.

#### **Operational Test of Air Compressors on Land**

Because air compressors used for air-lift are installed on the mining vessel with limited space, centrifugal air compressors consisting of three stages of low, middle and high pressure were developed.



The test of the compressors was conducted on land without a connection with the lift pipes. A 1,500 m long high pressure flexible hose designed for under water air supply was connected to the air compressors and a flow rate and pressure regulator was installed at the end.

The test was conducted under various conditions such as start-up, shut-down, lift-load fluctuation caused by changes of simulated nodule mixture ratio, and rapid change of the operating condition. In addition, the performance of the high pressure air hose and the load that was put on connecting devices of the hose to the lift pipes were measured, and the performance analyzing method of the stationary and nonstationary air transport characteristics was investigated.

## **NODULE COLLECTOR TEST**

### **Outline**

This was the most important test among the four tests carried out in 1997. There were four purposes as described below:

- Verification of the collecting performance of the collector;
- Investigation of the dynamic behavior of the collector in landing, recovery, and towing on the seafloor;
- Investigation of the functions of peripheral systems including a hybrid deep-sea cable with optical fibers and power cables, a data transmission system, and an underwater positioning system; and
- Preliminary measurements for evaluating the environmental impacts caused in the test area.

The test was conducted with a batch process. The test collector had a bin for collected nodules and a link with the cable to a surface vessel for power supply and communication was handled on the seafloor by a wire rope. Then the collector was towed and nodules on the seafloor were collected. Finally, the collector was recovered and lifted on to the vessel when the bin was filled with the scheduled amount of nodules.

About two months before the test, five mooring systems with a sediment trap and a current meter on each system were installed around the test area. The seafloor sediments were sampled prior to the collector test for the analysis of the background benthos. Effects on the seamount environment by the collector test was preliminarily investigated with the data.

The outline of the collector test is schematically shown in figure 1.

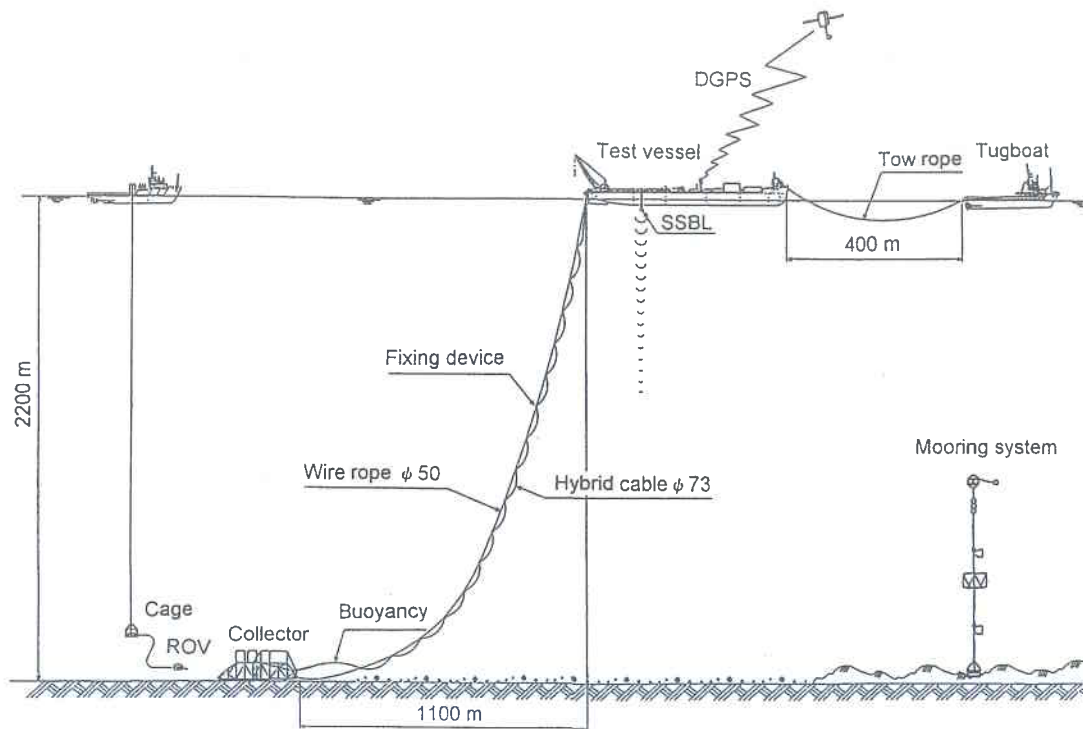

Figure 1 - Schematic outline of nodule collector test

### Test area

The test was carried out in a narrow terrace-like area on a seamount, one of the Marcus-Wake Seamounts in the North Pacific. The depth is about 2,200 m, and the average abundance and diameter of seamount nodules are 15.6 kg/m<sup>2</sup> and 15 mm, respectively.

The area usable for the test in the terrace was supposed to be about 2 km in length and about 0.5 km in width. Test conditions were very hard because the layer of calcareous sediments ranged from a few centimeters to a few meters, and thus base rocks were exposed in some areas, small rocks of several centimeters in size were found here and there.

Therefore, the Metal Mining Agency of Japan (MMAJ) conducted precise surveys over many years and prepared a detailed chart of the seafloor showing the topography and distribution of obstacles. This chart contributed greatly to the success of the collector test.

## Components of the Test System

### *Test vessel*

The mother vessel had an overall length of 122 m, width of 32 m, and dead-weight tonnage of 16,160 tons. It had sufficient space for the test collector, the hybrid cable and its winch, wire ropes and winches for rolling down and recovery of underwater equipment, an underwater positioning system, a control room, living facilities for researchers, power generating plants and other equipment for the test.

Since this vessel did not have propulsion, it was towed and navigated by a tugboat having gross tonnage of 692 tons.

### *Collector*

The test collector which had an overall length of 13.2 m, width of 4.6 m and height of 5 m was able to collect as much as 125 tons of manganese nodule per hour. It was originally developed for the comprehensive ocean mining test. For the test, the collector was altered as explained below.

- A nodule bin of 5 ton capacity was newly constructed for a batch test, while a crusher and fixed quantity feeder of nodules was removed.
- Since the collecting capability was too large for the 5 ton bin, two sets out of the four collecting units were removed. In addition, jet nozzles to blow nodules out from under the sledges to the space between the sledges were removed to reduce the effective collecting width from 4.5 m to 1 m.
- Since the test area was too narrow for the collector to make a landing after running on the seafloor under towed conditions, it was decided to land the collector while the vessel was kept at a fixed point. Furthermore, since impact absorption of the thin foraminiferous sediment layer is small, impact absorbers made of aluminum honeycombs were installed at the stem of the collector. To enlarge the angle of the forward incline when rolling the collector down, buoyancy materials were added.

After the above alteration, the total weight of the collector became 26.8 tons in air and 12.4 tons in water. The overview of test collector is shown in Figure 2.

Measuring instruments installed on the collector were : a heading detector, an incline detector, a 3-dimensional accelerometer, an altimeter, a water velocity meter, a towing force measuring meter, an impact accelerometer, a nodule counter, a turbidimeter and two TV cameras.

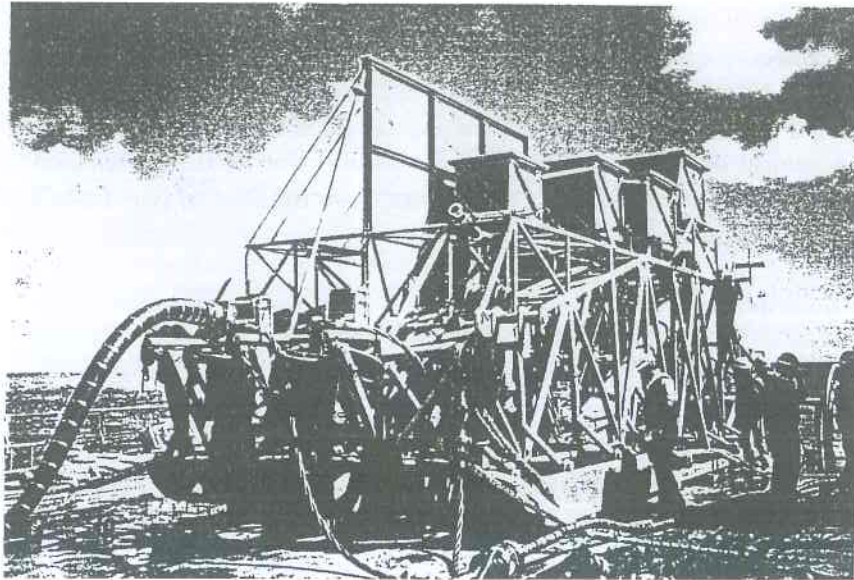

Figure 2 - Test collector

#### *Hybrid deep-sea cable with optical fibers and power supply cables*

The cable, which had an overall length of 2,827 m and outer diameter of 73 mm, consisted of four power cables; 6.6 kV for the nodule pick-up pump, 660 V for the hydraulic power pump, 660 V for measuring instruments, and 1.65 kV for auxiliary use as well as four optical fibers of eight core units.

#### *Wire rope for underwater instruments*

The collector was rolled down, towed, and pulled up for recovery by a wire rope having a diameter of 50 mm connected with the collector via a freely-rotating swivel. The hybrid cable was fixed on the wire rope every 50 m.

In this case, attention should be paid to twisting caused by load on the wire rope. If the twist of the wire rope gets back and the hybrid cable winds around the rope, recovery of the collector will become impossible.

To avoid such an accident, a wire rope having very low possibility of twisting by load was developed and used. In addition, a revolvable fixing device was developed so that the returning of rope twist would not affect the hybrid cable.

#### *Underwater positioning and navigation*

As mentioned above, the test area was very small and the landing space for the collector was limited to a much narrower area.

To tow the vessel by a tugboat, with no propulsion, to a proper place for landing the collector and to roll it down to a proper point of the seafloor, highly advanced navigation technology was required. In order to accomplish this, a high precision, super short, base, line underwater acoustic positioning instrument was developed. Great attention was also paid to the selection of the instrument for navigation and the Differential Global Positioning System (DGPS) was installed on the vessel and the tugboat.

### **Operators of Collector Test**

The personnel for the test consisted of about fifty operators from TRAM excluding the crew of the tugboat and an additional auxiliary tugboat.

For the preliminary investigation of effects on the seamount environment by the collector test, MMAJ deployed the observation systems and sampled some sediment cores prior to the collector test. NIRE cooperated with TRAM and MMAJ.

### **Results of Collector Test**

During the test period, including going to and returning from test area, there were three typhoons. Though the maximum wave height was 5 m there were, two times when the collector tests were conducted successfully from June 4 to 10, 1997 under gentle sea conditions.

Since details of the data obtained are under analyses, summaries are provided below.

#### ***Mining distance***

The actual mining distance of the collector was 215 m for the first test.

In the second test, it was 320 m in total, which included three intermittent collection times. The total distance for mining of these two tests was 535 m.

#### ***Collection efficiency***

The amount of nodules collected was 7.25 tons in total. Since the abundance of nodules in the test area was 15.6 kg/m<sup>2</sup> and the pick-up width was 1 m, the collecting efficiency was estimated as 87%.

Due to the small size of the test area and the limited capacity of the nodule bin of the collector, continuous collection at a constant speed was impossible. The towing speed of the collector fluctuated between 0.3 and 0.8 knots during the mining. However, if it is possible to assume that nodule abundance on the seafloor was constant, the records of the nodule counter showed better collection efficiency during the slower towing speed qualitatively.

### *Dynamic behavior of collector*

The behavior of the collector during towing was stable and it had no significant effect on the collection efficiency. The pitch angle during towing was 0.7 degree upward against the surface of the seafloor due to the towing wire rope. Since the Coanda effect was utilized as the collecting mechanism, it did not give a significant effect on the collection efficiency. This is also reinforced by the fact that there was no significant difference in collection efficiency between the right and the left collecting unit even in cases where the flow-up nozzles were set at different angles in the right and the left units.

### **POST - MINING OBSERVATIONS by ROV**

A commercially-operated ROV was used for observations of the collector tracks and ambient conditions about one month after the test. The system has a cage at the end of a primary cable of 2, 150 m length. The ROV was launched from this cage with a secondary cable of 150 m length. The maximum operating depth was 2,250 m. For navigation and under water positioning, DGPS and a super short base line system were used. Seafloor observation tools installed on the ROV were a TV and a still camera.

The two collector tracks were fully observed from the landing point to the take-off point. Because of narrow views of photos taken by the still camera, the TV images were used in the analysis. Many observation results such as a collector landing area as shown in a nodule pick-up area, and a collector take-off area were obtained from the first tow.

### **Post Mining Observations by a Side Scan Sonar**

A side-scan sonar was towed two times at a height of 40-50 m above the sea floor about one year after the collector test. During the operation, the Global Positioning System for navigation and the long base line system for underwater positioning were used. Because the height, 40-50 m, was very low, detailed seafloor images were obtained.

The entire first tow and the first half of the second tow were included in the images. Comparing the locations of the tracks and some structural outcrops with the detailed chart of the test area, the precise locations of the two tracks were easily defined beyond the accuracy of SSBL used in the collector test.

## **Post Mining Observations by a Towed Seafloor Observation Camera System**

The seafloor observation camera system was deployed at about 3 m off the sea floor by an umbilical cable just after the side scan sonar operation. It was towed at a speed of about 0.5 m/s with real time TV camera observations and many sets of stereo photos were taken at interesting places by orders through a manual shutter trigger onboard the vessel. The first track was traversed four times and the second track two times by the camera system.

## **CONCLUSIONS**

The ocean test of Japan's nodule mining system in 1997 was very successful. The nodule collector test in a high nodule abundance terrace-like area on a seamount was most satisfactory. The collection efficiency of 87 % was satisfactory. In addition, much valuable data and information about the operation and control of the nodule collector were obtained. This knowledge will contribute greatly to commercial nodule mining in the future.

From some post-mining observations, such as by a ROV, a side scan sonar, and a towed seafloor observation camera system, results were confirmed.

Aside from the nodule collector, equipment for other subsystems, such as ore lifting, machinery handling, and control and measurement, worked well and showed expected performance in the ocean test.

In a word, the foundation for nodule mining has been established through the 17-year R&D project. Further improvements and developments for commercial mining will be continued on the basis of this foundation, if necessary.

## **ACKNOWLEDGEMENTS**

The R&D project for a manganese nodule mining system was managed and financially supported by the Ministry of International Trade and Industries (MITI). The Technology Research Association of Ocean Mineral Resources Mining System and the National Institute for Resources and Environment conducted the actual studies for the project. Many officers, engineers, and researchers concentrated their efforts on the projects. The author would like to express his appreciation to everyone concerned with the project. The post-mining observations were conducted through the Environmental Impact Research on Marine Ecosystem for Deep-sea Mining entrusted to the Metal Mining Agency of Japan by MITI.

## REFERENCES

- Inokuma, A. (1995). "Current Status of Deep-sea Mineral Resources Development in Japan" Proc 1st ISOPE Ocean Mining Symp, Tsukuba, pp 9-13.
- Kuriyagawa, M. (1995). "NIRE's Research in Ocean Mining" Proc 1st ISOPE Ocean Mining Symp, pp31-33.
- Takahara, H, Handa, K, Ishii, K, and Kuboki, E. (1984). "Research and Development Project of Manganese Nodule Mining System in Japan," Proc 16th Offshore Tech Conf, Paper No 4782.
- Yamada, H, and Yamazaki, T (1998). "Japan's Ocean Test of The Nodule Mining System," Proc 8th Int Offshore and Polar Eng Conf, Montreal, Vol 1, pp 13-19.
- Yamazaki, T, Tsurusaki, K, and Chung, J. S. (1996). "Geotechnical Properties of the Pacific Seamount Sediments Measured by a Gravity Corer," Marine Georesources and Geotech, Vol 14, pp. 3-17.
- Yamazaki, T, and Sharma, R. (1998). "Distribution Characteristics of Co-Rich Manganese Deposits on a Seamount in the Central Pacific," Marine Georesources and Geotech, Vol 16, pp 283-305.
- Yamazaki, T, Kuboki, E, and Yoshida, H. (1999). "Tracing Collector Passes and Preliminary Analysis of Collector Operation," submitted for Proc 3rd ISOPE Ocean Mining Symp, Goa.
- Yasukawa, H, Ikegami, K, and Minami, T. (1999) "Motion Analysis of a Towed Collector for Manganese Nodule Mining in Ocean Test," Proc 9th Int Offshore and Polar Eng Conf, Brest, Vol 1, pp 100-107.
- Wakabayashi, S, Kuboki, E, Saito, T, Takata, A, and Iinuma, T., (1986). "Research and Development Project of Manganese Nodule Mining System in Japan — Status and Some Results of R&D," Proc 5th Offshore Mechanics and Arctic Eng, Tokyo, Vol12, pp 460-465.



## Summary of the presentation and discussions on Japan's Nodule Collector Test on a Seamount

Dr. Tetsuo Yamazaki, of the National Institute for Resources and Environment (NIRE) at Tsukuba, Japan, described Japan's Nodule Collector Test on a Seamount in his paper presented at the workshop. The successful large-scale test took place in 1997 following the completion of a 17-year national R&D programme on nodule mining systems. There were four objectives of the test: verification of nodule pick-up performance; investigation of the dynamic behavior of the collector during landing, towing and recovery; testing of peripheral systems including a hybrid cable carrying fiber optics and power, and data transmission and underwater positioning systems; and preliminary measurements of environmental impact.

The collector, with a pick up width of one meter was towed by wire rope at a depth of 2200 m on a seamount in the Marcus-Wake region of the Pacific. Towing speed fluctuated between 0.3 and 0.8 knots. Nodule abundance was 15.6 kg/m<sup>2</sup> and average nodule diameter 15 mm. The test covered 535 m in four legs and resulted in the production of 7.25 tons of nodules with an estimated collector efficiency of 87%. The Coanda effect was utilized in the pickup mechanism and the efficiency did not appear to be affected by slight variations in the pitch angle of the tow or of the nozzles.

Post-mining observations were carried out after one month from a commercial ROV using DGPS with a super-short baseline and video and photo imagery. Observations were made of areas of collector landing, nodule pick-up and collector take-off. One year after the test, detailed side scan images from an elevation of 40-50 m and photo images from an elevation of 3 m, were obtained and used successfully to confirm the test results. Further improvements for the development of commercial mining will be continued on the basis of this work if necessary, the speaker said.

Discussions following the presentation focused mostly on the currents regime on the top of the seamount and the environmental effects of the collector on the sediments that had been continuously measured during a period of 40 days. Some questions related to the follow-up technology for the collector and to the ongoing Japanese environmental programme (JET).

### **Currents and sediments on the seamount**

Videos of the surface of the seamount showed rippled sediments, nodule

covered areas and thin sediment cover above the crust indicating a current swept surface with a very low sedimentation rate. The re-sedimentation after the towing test was very limited on both sides of the track.

Is it possible, the speaker was asked, that the sediment cloud went further down? It appeared in the slide that the image ran across the track rather than along it. Mr. Yamazaki said in response that he had not yet considered every possibility but the bottom current measured in that area was very high, more than 1 knot (55 cm/s). The average was about 0.7 m per second and of course there was measurable circulation there as well. Strangely, the current speed and the current vector measured at the mooring and during the towing were quite different. The area was at the edge of the seamount and there were small hills around it so the circulation pattern may have been quite complex. A drift away from the area would have been a possibility. The difference in re-sedimentation thickness is still an elusive factor and one year after the test, the speaker said, he was not sure if it was still there. The nodule-piled ridge looked very black in the photo, which may indicate that almost no sediment was there. In his opinion the higher part was washed.

It was suggested by a participant that having run a sled to create parallel trenches and minor ridges, and there being a normal wash of fine grain material from the top of the seamount due to the currents, there would be a continuous collecting of fine material. The ridges would decrease the speed of the near bottom current so there would be an accumulation of sediment, especially in the trenches, which is indicated. That would be one explanation why the ridges in the photograph are clean of sediment. So, actually, what was measured in the photographic analysis of the brightness of these nodules could just be the result of sediment being trapped due to this irregular surface and might have had nothing to do with the actual collection test.

Someone else asked why there was upwelling around the seamount if the main current direction was vertical? Mr. Yamazaki said he did not know because in the seabed area that they had measured, the current vector went south. They had measured over the course of 40 days and the vector went to the south about 100 km., but in these rotations the vector moved toward the west about 50-60 km. He could not visualize the horizontal current itself or know anything about its particular direction.

He was also asked about the difference between the specific gravity of the deep-sea sediment and the seamount sediment. If the size was different so the density would have been different and perhaps the plume did not extend so far? Size is a very important factor, Mr. Yamazaki suggested; for example in this area sand particles went down very quickly but silty and clayey particles are still there. That can be verified by indoor tank tests. It is a small difference he said, because

the density itself is not as different as with siliceous and calcareous particles. It was suggested that it was mainly skeletal remains and foram shells in the sediments. They were clearly vinoid sediments and all the fine material had been carried away to leave a residual sediment in comparison to what would be found at greater depths. That settles much faster because of the size of the particles.

### **Future testing**

Asked about the next phase of the programme in mining technology related to collector or lift system Mr. Yamazaki said they had no plan right now because the Japanese Government had totally stopped research in mining technologies. They would continue to fund surveys for polymetallic sulphides and cobalt rich manganese crust and for the environmental assessment project.

### **The Japanese Environmental Test (JET) programme**

The speaker was asked to comment on the results of the JET program and indicated that in two or three years they would visit the JET site again. From the viewpoint of engineering, the results of JET are very important. From the sinking of the disturber into the sediment it will be possible to calculate how the commercial collector will sink into the soft sediment layer. Such kinds of important data have not yet been analyzed.

It was suggested that the workshop participants would be interested in the recovery of the biological community in that area as the site had been re-visited two or three times since the disturbance phase. The speaker related how they had visited there one year, and again two years, after the JET tests. The results of biological analyses showed that after two years the population of the benthos had recovered to its original level. That may have been due to the background fluctuation of the benthic population itself so it must be confirmed by going back to the site again in two or three years. That would be six or seven years after the experiment.

The Germans tested their core area six years after the initial disturbance so as to properly compare the results. Mr. Yamazaki said that the JET area should be revisited within the same six year time frame. In answer to a suggestion that the site was on the current swept seamount the speaker explained that it was a basic impact experiment carried out in the Japanese mining claim in the CCF Zone. Asked about the continuous current measurements over 40 days he said there were no significant variations of current during that time. The largest variation depended on the tidal cycle that was diurnal and the only other measured variation had a cycle of about 30 or 40 days.

## Chapter 12

# RESEARCH AND DEVELOPMENT OF DEEP-SEABED MINING TECHNOLOGIES FOR POLYMETALLIC NODULES IN KOREA

*Sup Hong*  
*Ocean Development System Research Center, Korea*  
*and Ki Hyune Kim*  
*Deep Sea Resources Research Center, Korea*

**Synopsis**

**Research and Development of Exploration Technology**

**Research and Development of Exploitation Technology**

**Future Plan**

**Aknowledgement**

**References**

**Summary**

## SYNOPSIS

Research and development (R&D) in deep-seabed mining technology in Korea began with the approval by the Preparatory Commission for the International Seabed Authority and for the International Tribunal for the Law of the Sea of the application submitted by the Republic of Korea in August 1994 for registration as a pioneer investor and for the allocation of a pioneer area. On behalf of the Ministry of Maritime Affairs and Fisheries (MOMAF) of the Korean Government, the Korea Ocean Research and Development Institute (KORDI) has been conducting exploration activities in the allocated area to fulfill obligations as a pioneer investor.

R&D in exploration and exploitation technologies for deep seabed poly-metallic nodules has been initiated by a national undertaking under the project "Technological Development for Deep Seabed Mining and the Protection of the Deep-sea Environment," which is being supported by the Ministry of Science and Technology (MOST). The national R&D project is planned as a 10-year endeavor from 1994 to 2003 and is divided into three parts: development of exploration technology and environmental study, development of mining technology and development of processing technology.

KORDI is taking a lead role in the R&D of exploration and exploitation technologies for deep seabed manganese nodules. Exploration and development of exploration technology are being successfully accomplished by KORDI. The Korea Research Institute of Ships and Ocean Engineering (KRISO), one of the engineering branches of KORDI, is conducting R&D activities for the nodule collector and the integrated operation technology, while the Korea Institute of Geology, Mining and Materials (KIGAM) is accountable for R&D in lifting technology.

Joint-research activities with institutions abroad also stimulated much progress of the R&D work during the initial stages. Moreover, industrial technology sectors have been involved in joint-research operations with the desire of simultaneous transfer of technological achievements to industry and vice versa. University R&D institutes have also been integrated into national R&D activities for basic research on underwater mining technology as well as training of experts for the future.

This paper outlines a brief overview of the plan and strategy of the Korean National R&D Project for deep seabed mining technology.

## RESEARCH AND DEVELOPMENT OF EXPLORATION TECHNOLOGY

### Exploration Activities

One of the primary concerns at the present stage is the relinquishment of the pioneer area, which is a major project with full support from the Korean government. The Republic of Korea will relinquish a total of 30 per cent of the allocated area of 150,000 km<sup>2</sup> by August 1999. Through the relinquishment of an additional 20 per cent of the allocated area by 2002, Korea's pioneer area of 75,000 km<sup>2</sup> will be delineated.

During the prospecting stage, the intervals for line surveys and sampling were approximately 30 km. However, in the exploration stage, the intervals of survey lines and sampling are required to be at least 5 km. The quality and efficiency of each survey is continuously upgraded using improved and state-of-the-art exploration equipment and data interpretation technologies in order to evaluate the area as precisely and accurately as possible.

The second purpose of the exploration activities by Korea is to conduct environmental protection studies for potential mining impacts on the water column as well as on the deep seabed. Natural variation of chemical, biological, and geological conditions around the allocated area has been intensively investigated since 1995.

Manganese nodules, sediments, sea and pore waters, and biological specimens have been sampled at hundreds of sampling stations by means of free fall grab, box corer, piston corer, multiple-corer, Rosset water sampler with CTD and other sensors, bongo net, beam trawler, etc. Various instruments have been utilized for acquisition of geophysical data including multi-beam echo-sounding for topography, narrow-beam echo-sounding for precision depth measurement, and shallow seismic survey for stratigraphy of bottom sediment layer. In addition, enormous volumes of still photo and video records have been taken utilizing underwater cameras.

### Development of Advanced Exploration Technologies

The Ministry of Science and Technology (MOST) of the Korean Government has been supporting another R&D project in exploration technologies. KORDI is also currently in charge of and has been involved with developing advanced exploration technologies, i.e.,

- Acquisition of high quality data
- Interpretation techniques for acquired data
- Application of new technology developed in survey
- Cost-effective survey system, and so on.

Much of the work has been focused on the analyses of reflected sonic signals and back-scattered signals in order to classify and interpret the characteristics and intensities of the signals from sea-bottom materials having different physical and chemical properties, i.e., hardness, porosity, water content, constituents, minerals and metals, etc.

The reflected and back-scattered signals from the sea-bottom should depend on the reflecting materials and energy sources. Different signal frequencies (3.5 kHz, 10.2 kHz, 12kHz, 70~75 kHz and 100 kHz) are employed as acoustic sources. Through such research, KORDI is aiming to classify bottom conditions, primarily the occurrence and distribution of nodules on the sea-bottom without the need for verification through *in situ* sampling or by deep-sea camera system which can be very time consuming and difficult to handle.

KORDI has also been working to develop an image processing technique, using photographs of the sea-bottom to semi-automatically estimate the coverage and size distribution of nodules. Currently, photographs of the deep seabed are taken using 35mm still and video cameras attached as part of the Deep Tow Imaging System. The 35mm still camera is fastened to the free fall grab to take photographs when the grab arrives at the sea bottom. It is also programmed to take photographs of the sea bottom every 30 seconds while the Deep Tow Imaging System is being slowly towed at the speed of 1 to 2 knots.

An enormous quantity of the still photographs has been collected during previous surveys. Major features extracted from the still photographs are the area coverage and size distribution of polymetallic nodules. The information on the seabed characteristics extracted from the photographs is used to evaluate the size and quality of deposits and quantity of resources. Because a large volume of images are difficult to manually extract and interpret, a digital image processing technique is being perfected and applied to the process.

Developed 35mm negative films are digitized by means of a film scanner. Height information recorded on the film is used to compensate for the distortions resulting from non-uniform illumination. After compensating for non-uniform illumination, nodule areas on the processed images are recognized and separated from the background for the nodule characteristics. Nodule coverage and distribution of nodule diameters are calculated from these images.

## RESEARCH & DEVELOPMENT OF EXPLOITATION TECHNOLOGY

### Overview

In planning of the R&D programme on deep-seabed mining technology the objective of commercial mining of polymetallic nodules in the 2010s or later has been taken into account. The 10 year R&D programme is to be followed by at-sea validation test of mining technology before commercial mining at mine sites. The goal of the 10 year R&D programme is on research and development of core technologies required for the design of pilot mining system and/or its substantial subsystems.

The first phase (1994~1996) of the national R&D programme consists of three steps (Yang 1995):

- Feasibility study on mining technology
- Concept design of deep seabed mining system
- Basic design of selected core subsystems

The pilot mining tests of polymetallic nodules at the end of 1970s by international consortia – OMA, OMI, KCON and OMCO – have been applied and utilized in preliminary investigations and feasibility studies on deep-seabed mining technologies. The concept of continuous mining, i.e. a continuous flow of nodules from a collector on the seabed to the surface through lifting pipe is valid in principle. A total mining system consists of mining vessel, lifting pipe and pumps, collector(s), and flexible link(s) between collector and lifting pipe. Upgrading of the technologies adopted for the pilot mining test systems has been the objective of the feasibility study.

The concept design of commercial mining system has been based on enhancement of the performance in core subsystems, i.e., self-propelled nodule collector, enhanced buffer function and integrated mining operation system. Environmental acceptability and impact of mining technology, hot-issues in the 1990s, have been taken into consideration for R&D particularly of the nodule collector. The concept of a commercial mining system for polymetallic nodules consists of following subsystems:

- Mining vessel
- Lifting pipe, pumps and buffer
- Flexible hose
- Self-propelled collector



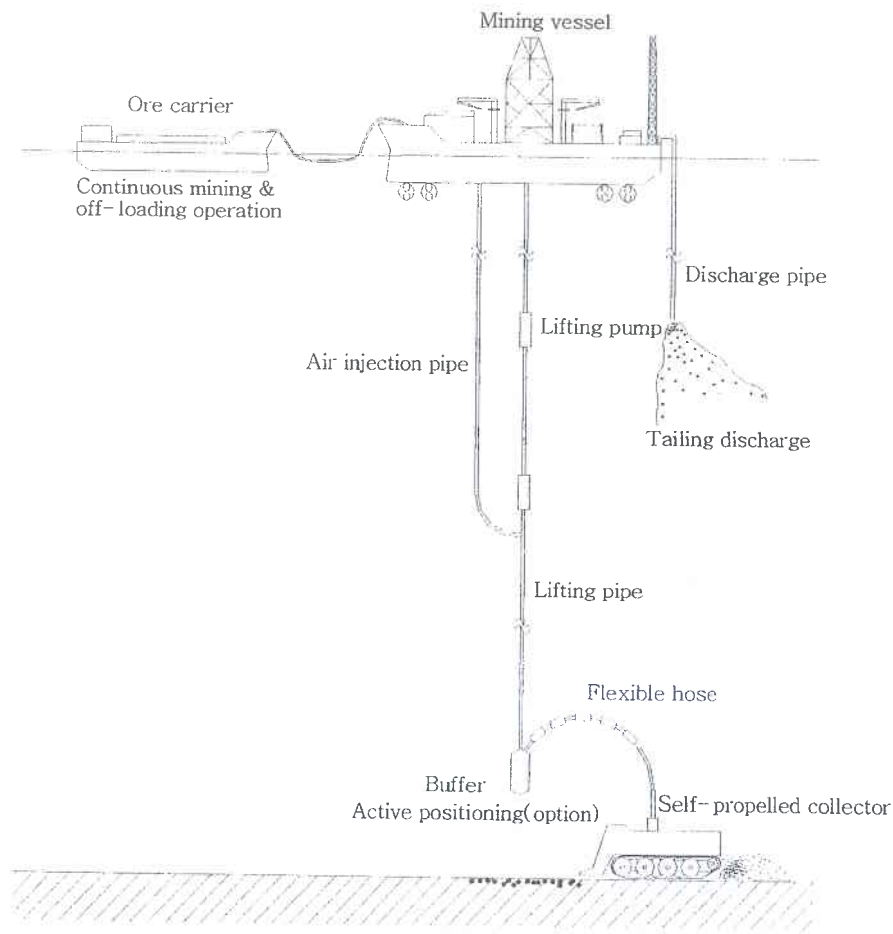

Figure 1 - Concept of Commercial Mining System of Polymetallic Nodules

Strategies for the earliest achievement in core technologies have been adopted and put into practice. Development of a Hybrid Nodule Pick-Up Device (July 1995 – October 1997), a joint project between KRISO, HMRI and THETIS of Germany has built a foundation for accelerating the R&D programme.

The participation of Hyundai Maritime Research Institute (HMRI) of Hyundai Heavy Industry (HHI) was intended to facilitate simultaneous technology transfer to private industrial sectors and caused an increase in national interests. R&D of mining technology has been conducted at laboratory scale and in computer simulation approaches.

In the second phase (1997–1999), the main objective of R&D is development of test models on an intermediate scale, whose performance will be verified under

intermediary conditions. For performance evaluation, the target water depth is in the order of 200m. The test system being configured in an integrated manner is supposed to be applied in investigation and verification of remote operation and integrated control system. A self-propelled test collector providing 1/10 capacity of commercial production rate by two units is being considered.

The third phase (2000~2003) is planned for designing a pilot mining system and implementing a totally integrated operation system, the ultimate goal of national R&D programme. *In situ* performance of the pilot mining system will be evaluated and improved in a pilot mining test programme. All technological data and know-how compiled during the pilot mining test will be implemented to obtain Korea's own model of a commercial mining system for deep-seabed polymetallic nodules.

### **Nodule Collector**

The performance and efficiency of a deep-seabed collector is a primary factor in achieving feasibility of commercial production of deep-seabed polymetallic nodules. The efficiency of the nodule collector depends on vehicle mobility and the performance of a pick-up device. Vehicle design requires detailed exploration data on seabed topography and mechanical properties of sediment. Since the load bearing capacity and trafficability of sediment in the claimed area are very low, vehicle types optimized for soft soil are being considered.

The pick-up device is carried by a vehicle and has to continuously separate polymetallic nodules from the sediment layer. The pick-up process for polymetallic nodules causes inevitable disturbance of deep seabed sediments. Minimal disturbance of the environment within an acceptable limit is the critical problem. Pick-up efficiency is likely to be influenced by the vehicle performance, speed and its behaviour. Hence, operations of vehicle and pick-up device have to be controlled in an integrated manner.

### ***Nodule Pick-Up Device***

Pick-up technology was selected as core technology in the initial stage. KRISO and HMRI had contracted a joint project with THETIS, the patent holder of the hybrid nodule pick-up device, for the purpose of technology transfer of hybrid pick-up device.

The hybrid pick-up device consists of a hydraulic lifter and mechanical conveyor. A pair of water jets combined with baffle plates loosens and separates polymetallic nodules from sediment without mechanical contacts. Then, a rotating fin-scraper recovers only nodules from sediment plume and transports them into the collector (Amann 1995, Min et al 1997). This double process of nodule separation from sediment reduces transportation of fine sediments to the surface.

The performance of the hybrid pick-up device was evaluated and improved through a number of model tests at KRISO. The performance and characteristics of the hydraulic lifter have been experimentally investigated. The basic system performance of the hybrid pick-up device had been verified. Compared with other pick-up concepts, mechanical types or pure hydraulic types, e.g. Coanda nozzle, the performance of a hybrid pick-up device has been validated as less sensitive to vertical clearance between seabed and water-jet nozzles. Sufficiently high pick-up efficiency is obtained in vertical clearance range of 100 – 200 mm. The energy requirements remain in the moderate range (Hong 1996, 1997).

KRISO's own research work resulted in a substantial enhancement to the initial design of the hybrid pick-up device. Various know-how have been acquired in addition to the model test technique itself, for instance,

- Simulation of artificial nodules and sediment bottom
- Interaction of water-jet with forward speed
- Effect of baffle plates shape and geometry
- Design and manufacture of fin-scraper, etc. (Hong et al. 1999)



Figure 2 - Model Test of Hybrid Nodule Pick-Up Device at KRISO

### *Link and Motion Control of Pick-Up Device*

Special efforts have been concentrated on the design of a link assembly of the pick-up device. The link assembly supports the pick-up device on the vehicle chassis of the nodule collector and simultaneously controls the motion of the pick-up device relative to the vehicle motion. For the best performance of the pick-up device, the hydraulic lifter must be positioned in the optimal range of vertical clearance and adjusted to be parallel to seabed topography. Vehicle behaviour is primarily concerned with the motion control of the hydraulic lifter, i.e. hybrid pick-up device.

A novel link assembly of the pick-up device has been developed. The novel design consists of 6 hinge-link elements and 4 linear actuators that enable decoupled motion of the pick-up device, i.e. translational and rotational motions are controlled independently. This property is of particular interest for real-time control of the pick-up device relative to the seabed. Advantages of the novel link assembly are,

- Simple and decoupled control of altitude and attitude of pick-up device
- Stable design of link structure

Based on the kinematic analyses, inverse dynamic analyses and design sensitivity analyses, the basic design of the pick-up device link system has been completed (Hong et al. 1997).

### *Collector Vehicle*

Technology development of the collector vehicle is a challenging task. Together with the nodule pick-up device, the collector vehicle determines productivity of the collector and, furthermore, the feasibility of nodule collecting operation in deep seabed.

Cost benefit analyses suggest that deep seabed mining of polymetallic nodules will be profitable when a large scale mining system is implemented with yearly production capacity of 100~300 million wet tons. A nodule collector of max. 500 ton/h is a prerequisite to fulfill such a commercial mining system (Herrouin et al 1989).

A caterpillar-type tracked vehicle has been adopted for nodule the collection due to poor trafficability of the deep seabed sediments. A large contact area and low contact pressure of the tracked vehicle reduces the sinkage and provides the mobility of vehicle. Soft sediment calls for a belt-type track of reinforced rubber, high grouzers, high track tension, narrow interval of road wheels, and so on.

Notwithstanding that tracked vehicles are popular among various kinds of off-road vehicles, performance of tracked vehicle on soft bottom is very complex. Technological difficulties and complexities of any underwater tracked vehicle are enormously high.

For the purpose of developing the nodule collector and conducting research on this core technology, the following subjects are being investigated:

- Development of computer simulation programme of the tracked vehicle
- Experimental investigation on modeling of soil mechanics
- Model test of tracked vehicle at laboratory scale
- Validation of computer simulation programme
- Experimental investigation on the optimal slip condition

A dynamic simulation programme of the tracked vehicle in time domain has been developed and verified by comparison with a simplified commercial computer code.



Figure 3 - Test Equipment on Tractive Performance Tests

A model test facility has been designed and is under construction. The size of the soil bin is 4.8m (L) x 2.6m(B) x 0.6m(H). Measuring equipment has been manufactured. Three electric servo-motors are in place to control the speed and position of measuring equipment. Six load cells are used to measure the bottom pressure and tractive force.

### *Test Collector*

The main objective in the second phase (1997~1999) of the R&D programme was the development of a test collector. The application objectives of the test collector are,

- Evaluation of system performance in intermediate scale
- Development of operation and control system for test
- Application to the performance evaluation in intermediary condition

The system performance of the test collector will be investigated in a large basin of 56m(L) x 30m(B) x 4.5m(H). An open pit test is required for a precise performance test of the tracked vehicle.



Figure 4 - Large Test Basin (56m x 30m x 4.5m) at KRISO

The test collector is designed to be driven using electro-hydraulic power. The basic design of the test collector involves the following subsystems and/or components,

- Hybrid nodule pick-up device, links and hopper
- Reinforced rubber tracks, tension cylinder and driving units
- Vehicle chassis structure
- Power pack and hydraulic assembly unit
- Control unit and electronic boxes
- Electrical junction box
- Umbilical cable
- Surface control and monitoring unit

The construction and commissioning of test collector are planned for the end of 2000.

### **Lifting Technology**

In the first phase (1994~1996) of the R&D programme, basic studies and investigations of the characteristics of lifting pump flow were carried out by KIGAM. Analysis models of the lifting flow mechanics in the literature have been surveyed. Based on the analytical models of two-phase (solid-fluid) and three-phase (solid-fluid-gas) flows in a vertical pipe, computer programs for steady and unsteady flows have been implemented.

The developed computer codes have been utilized for a feasibility study and conceptual design of lifting system. The required power estimation of the hydraulic pump system and air-lift system for commercial scale lifting system has been conducted by means of steady flow analyses. Optimum design parameters such as pipe inner diameters, flow speeds and nodule concentration and so on have been investigated.

Unsteady analyses provided the information on the installation depths of pumps, air-injection position, the optimal pipe diameter expansion of air-lift system and separator design parameter (Lee et al. 1997, Yoon et al. 1998).

In the second phase (1997~1999), a small-scale test facility for two-phase flows was designed and constructed in a laboratory. Flow patterns have been examined by changing the volumetric concentration of nodules, nodule diameters and inner pipe diameters. The test results were used for validating the developed computer programme.

Construction of a 30 m-high test facility is planned for experiments of two-phase and three-phase flows. This test facility will be utilized for verifying and improving the computer programmes.



Figure 5 - Model Test Facility of Lifting Technology



## **Integrated Mining Operation Technology**

The offshore oil and gas industry is leading the way in development of ocean engineering technologies. In particular, riser technology and dynamic positioning system (DPS) have enabled development of deep-water oil fields. For implementation of commercial mining of polymetallic nodules at 5,000m water, offshore oil industry technology is also applicable.

For research and development of integrated mining operation technology, the following subjects are included:

- Development of dynamic simulation programme of total mining system
- Dynamic simulation of mining vessel
- Dynamic simulation of lifting pipe
- Dynamic simulation of flexible hose
- Dynamic simulation of tracked vehicle
- Development of dynamic control technologies
- Simulation of dynamic positioning and route tracking of mining vessel
- Control technology of buffer position relative to the nodule collector
- Development of operation system of nodule collector
- Establishment of integrated communication network system

### ***Dynamic Simulation of Lifting Pipe***

To produce polymetallic nodules from 5,000 m water depth, structural safeties and dynamic behaviour of lifting pipes are of great importance. Lifting pipes conveying the polymetallic nodules up to the surface and simultaneously supporting power lines and signal cables at the outside will play the role of the main artery of the total mining system.

3-D computer programs, OMPA3 for dynamic simulation of lifting pipe and flexible hose has been developed (Hong 1995, 1997). The time-domain program OMPA3 has been utilized for

- Dynamic analysis of axial, bending and torsional vibration of lifting pipe
- Dynamic analysis of tow maneuvering of lifting pipe
- Dynamic analysis of flexible hose

### ***Buffer Position Control Technique***

Basic research is being conducted on the development of a control algorithm to keep the configuration of the flexible hose optimal, by means of active control of the buffer position relative to nodule collector.

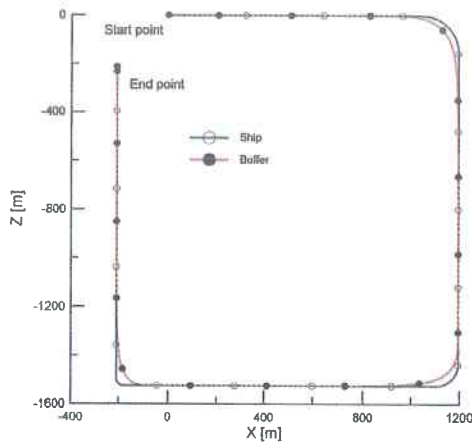

Towing Track Pattern No. 1

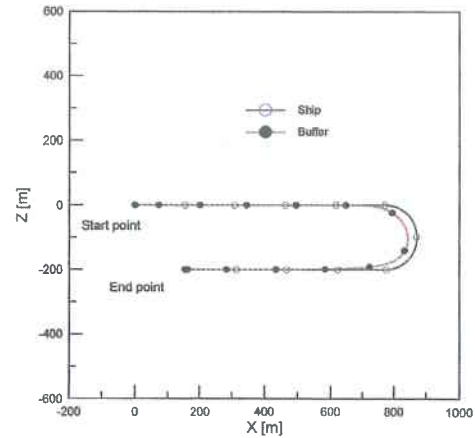

Towing Track Pattern No. 2

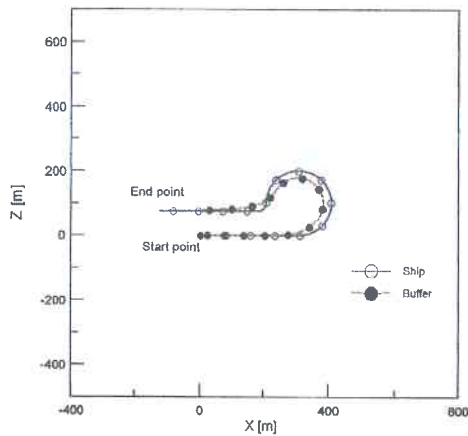

Towing Track Pattern No. 3

Figure 6 - Results of Dynamic Analysis of Towed Behaviors of Lifting Pipe

### *Dynamic Positioning and Route Tracking of Mining Vessel*

KRISO has put much effort in the past several years to develop Dynamic Positioning (DP) control programme and model test technique (Kim et al. 1997, Hong et al. 1997). An experimental system for the DPS model test has been established in a square basin 56m(L) × 30m(B) × 4.5m(D). The square basin at KRISO is capable of realistically modeling the ocean environmental conditions; multidirectional irregular waves, current and wind. The experimental system has been designed for route tracking tests as well as positioning tests (Kim et al. 1998).

The DP control programme has been developed on the basis of PID-controller, Optimal controller and Kalman filter. All commands and measured data are transferred through either serial communication or a wireless network system in the basin. The DP control programme displays all obtained data in real time, i.e., vessel motions, thruster RPM, azimuth angles and so on. Azimuth thruster units have been designed and manufactured. The servo-motors of the azimuth thrusters are controlled by onboard computer. A DP simulation programme has also been developed, which provides 3-DOF planar vessel trajectory, required thruster and acting environmental forces.

It is expected that the experimental system and the DP simulation programme will enable optimal design of mining routes and patterns for polymetallic nodule production.

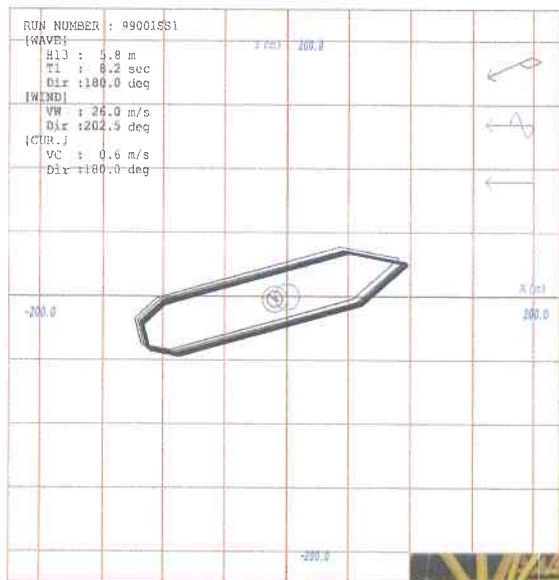

Figure 7 - DP Simulation of Drillship in Waves, Wind and Current and below, a Mining Ship Model Test



### Dynamic Simulation of Tracked Vehicle

The 2-D dynamic analysis programme of the tracked vehicle (TVDP) has been developed for time-domain. By using TVDP, variable modeling of tracks, road wheels and their suspensions, sprockets and idlers is possible. Particularly, the dynamic behavior of tracks can be investigated through a discrete modeling of tracks with mass-spring-damper elements. Contact problems of track elements with road wheels and bottoms have been formulated and implemented in the analysis programme. Two kinds of soil models are implemented in the programme code, and it is easy to include other models (Han et al. 1998).

TVDP is being applied to a vehicle design of the test collector. Accuracy of TVDP will be verified by model tests in a laboratory. A 3-D dynamic analysis programme is being developed.

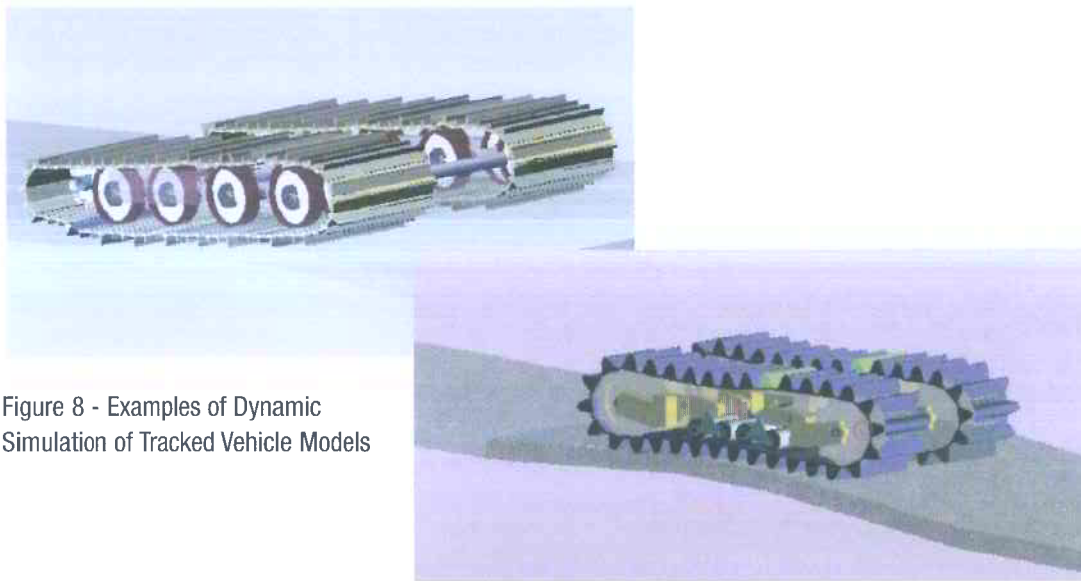
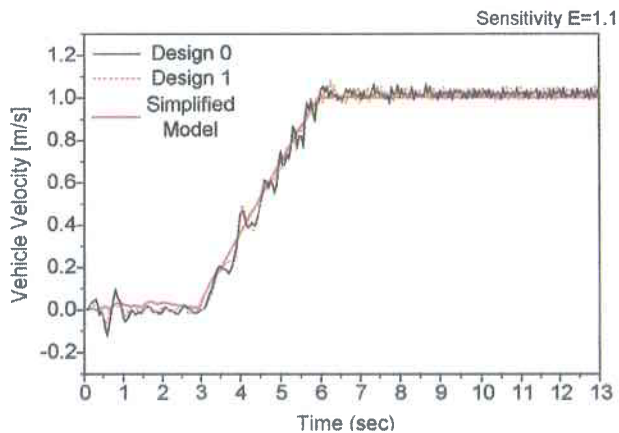

Figure 8 - Examples of Dynamic Simulation of Tracked Vehicle Models



## FUTURE PLAN

To fulfill the ultimate objectives set out by the national R&D programme, that is to design a pilot mining system by 2003, the challenge required more intensive cooperative works among participating institutions and demands intermediate steps for a successful scale-up of technologies from laboratory scale to pilot scale.

The intermediate scale is of particular importance in Korea's R&D strategy for deep-seabed mining technology. Technological achievements obtained in the laboratory have to be adapted to deep seabed pressure conditions, to be integrated to allow control by remote operation, for a handling system, and for the complexity of communication system to name a few requirements.

This first step of practical application of developed technologies may entail high technical risk and requires a large investment while subsequent profits may still be low and uncertain. Hence, international cooperation in the intermediary phase will be very effective to reduce unnecessary risks in technical as well as economic aspects and for sharing of technical and environmental data.

In the remainder of the national R&D programme, efforts and investment will be focused in the following areas:

- Development of exploration technology
- For effective delineation of mining area
- To acquire geoscientific technical data for development of nodule collector
- *In situ* measurement technique for geotechnical information of seabed sediment
- Robust design of pilot collector
- Nodule feeding system to buffer
- Interface between nodule collector and flexible hose
- Design of lifting pump system and pipe string
- Development of an integrated operating system
- Performance evaluation of mining system in 150~200m water
- Cooperation with foreign countries in performance of evaluation test

The Government of the Republic of Korea is presently planning a second long-term programme as the next step after the third and final relinquishment of the portions of the pioneer area, which will determine the schedule and strategy for development of deep seabed mineral resources. As a late comer in underwater mining, Korea has an open policy for cooperation with other pioneer investors to reduce the risk of failure and to lessen the high cost burden.

Regarding the rapid expansion of cost requirement for technology scale-up and sea trials especially, collaborations with other pioneers in the intermediate steps before the pilot scale is of important interest for Korea. Cooperative working contracts with other pioneer investors having similar mining concept and/or being in comparable stages would be most fruitful for mutual interests.

#### **ACKNOWLEDGEMENT**

The authors gratefully acknowledge the support of Ministry of Science and Technology, Korea for R&D of deep seabed mining technology, and wish to acknowledge their appreciation to the Ministry of Maritime Affairs and Fishery for promotion of this paper. Dr. Chi-Ho Yoon of Korea's Institute of Geology, Mining and Materials is sincerely thanked for his cooperation in the R&D works. Prof. Hans Amann at University of Berlin, Germany is recognized particularly for his contributions in the initial stage of the R&D work. Last, but not least, the authors want to thank colleagues and partners for their efforts and overseas colleagues for kind discussions and for their friendship.

## REFERENCES

### Exploration Technology

Hyun, JH., Choi, JK., Yang, EJ, and Kim, KH. (1998) "Biomass and Productivity of Bacterioplankton Related to Surface Water Divergence in the Northeast Equatorial Pacific Ocean", *The Journal of Microbiology*, 36: pp. 151-158.

Hyun, JH., Kim KH., Chi, SB, and Moon, JW. (1998) "Distribution of ATP in the Deep-Sea Sediment in the KODOS 97-2 Area, Northeast Equatorial Pacific Ocean", *The Sea: Journal of the Korean Society of Oceanography*, 3: pp.142-148.

Hyun, JH., Kim, KH., Jung, HS and Lee KY. (1998) "Potential Environmental Impact of Deep Seabed Manganese Nodule Mining on the Synechococcus (cyanobacteria) in the Northeast Equatorial Pacific: Effect of Bottom Water-Sediment Slurry", *Marine Georesources and Geotechnology*, 16: pp. 133-143.

Jung, HS, Choi, MS, Kim DS, Cha, HJ, and Lee, KY. (1998) "Geochemistry of rare earth elements in two-color core sediments from the Korea Deep Ocean Study (KODOS)-90 site, NE equatorial Pacific", *Geochemical Journal*, 32: pp. 281-299.

Jung, HS, Lee, CB, Jeong, KS, and Kang, JK. (1998) "Geochemical and mineralogical characteristics in two-color core sediments from the Korea Deep Ocean Study (KODOS) area, northeast equatorial Pacific", *Marine Geology*, 144: 295-309.

Jung, HS and Lee, CB. (1999) "Growth of diagenetic ferromanganese nodules in an oxic deep-sea sedimentary environment, northeast equatorial Pacific", *Marine Geology* 15: pp. 127-144.

### Exploitation Technology

Herrouin et al. (1989) "Manganese Nodule Industrial Venture Would Be Profitable: Summary of a 4-Year Study in France", *Proc. Offshore Technology Conference, OTC 5997, Houston*, pp. 321-332.

Amann, H. (1995) *The Initial Report of KRISO-HMRI-THETIS Joint Project*, October 12.

Yang, SI et al. (1995) *A Study on Mining Technology of Deep Seabed Manganese Nodules*, KIMM Report No. BSN350-1907.D (in Korean).

Hong, Sup (1995) "Three Dimensional Analysis on Behaviour of Mining Pipe of Deep Seabed Mineral Resources", *Proc. 1st ISOPE Ocean Mining Symposium, Tsukuba, Nov. 21-22*, pp. 69-74.

Hong, Sup et al. (1996) *Development of Pick-Up Device for Deep Seabed Manganese Nodules (I)*, KIMM Report No. UCK031-2012.D, November, (in Korean).

Hong, Sup. et al. (1997) *Development of Pick-Up Device for Deep Seabed Manganese Nodules (II)*, KIMM Report No. UCK035-2074.D, November, (in Korean).

Hong, SY, Kim, HJ, and Lee, CM. (1997): "Development of a Model Scale Dynamic Positioning System", *Proc. 7th Int. Offshore and Polar Engineering Conference, Vol. 3, Hawaii*, pp. 664-671.

Kim, HJ, Won, YS, and Choi, HS. (1997) "The Position Keeping Performance of a Turret-Moored Tanker Assisted by Dynamic Positioning System", *Proc. Offshore Mechanics and Arctic Engineering, Vol. IA, Yokohama*, pp. 179-186.

Min, KS, Shim, JY, Hong, S, and Choi, JS. (1997) "Conceptual Design of a Hybrid Pick-Up Device for Deep Ocean Mining", Proc. 2nd ISOPE Ocean Mining Symposium, Seoul, Nov. 24-26, pp. 91-94.

Hong, Sup, Choi, JS, and Shim, JY. (1997) "A Kinematic and Sensitivity Analysis of Pick-Up Device of Deep-Sea Manganese Nodule Collector", Proc. 2nd ISOPE Ocean Mining Symposium, Seoul, Nov. 24-26, pp. 100-104.

Hong, Sup. (1997) "3-D Dynamic Analyses of Lifting Pipe Systems in Deep Seabed Mining", Proc. 2nd ISOPE Ocean Mining Symposium, Seoul, Nov. 24-26, pp. 75-81.

Lee, HS et al. (1997) "Overflow Volume Generated by Air-Lift Pump", Proc. 2nd ISOPE Ocean Mining Symposium, Seoul, Nov. 24-26, pp. 117-121.

Hong, Sup. et al. (1998) "Development of a Hybrid Pick-Up Device for Deep-Seabed Mining", presented at 8th Pacific Congress on Marine Science and Technology, Seoul, June 15-19.

Han, HS, Hong, S, and Shin, SJ. (1998) "Development of DADS Track Module for Dynamic Analysis of Tracked Vehicles", Proceeding of Korean Automotive Engineering Conference, Seoul, Nov. 27-28, pp.847, (in Korean)

Kim, HJ, Hong, SY, and Hong, S. (1998) "An Experimental Study on Position Tracking of a Ship in Waves", presented at 8th Pacific Congress on Marine Science and Technology, Seoul, June 15-19.

Yoon, CH, Kim, IK, and Kwon, KS. (1998) "Analysis of Unsteady Slurry Flow Mechanism in Pipe for Air Lifting System", presented at 8th Pacific Congress on Marine Science and Technology, Seoul, June 15-19.

Hong, Sup, Choi, JS, Kim, JH, and Yang, CK. (1999) "Experimental Study on Performance of Water-jet Pick-Up Device of Manganese Nodule Collector", Proc. 3rd ISOPE Ocean Mining Symposium, Goa, Nov. 8-10, (to be published).



## Summary of the presentation and discussions on Research and Development of Deep Seabed Mining Technologies for Polymetallic Nodules of Korea

Dr. Sup Hong of the Ocean Development System Research Center presented the paper prepared by Mr. Ki Hyune Kim of the Deepsea Resources Research Center and Dr. Sup Hong on the Government of Korea's activities in R & D of Deep Seabed Mining Technologies for Polymetallic Nodules in Korea.

Dr. Hong provided participants with an overview of the Government of Korea's activities with respect to meeting its obligations as a pioneer investor and developing a commercial nodule mining system. Korea's entry to this field began in 1994 on registration as a pioneer investor. Investment obligations in exploration were carried out by the Korean Ocean Research and Development Institute (KORDI) on behalf of the Ministry of Maritime Affairs and Fisheries (MOMAF). Research and development in technologies for exploration and exploitation are supported by the Ministry of Science and Technology (MOST). Started in 1994, this 10-year program is expected to continue through 2003. As part of this programme, manganese nodule exploration technology is being developed by KORDI, nodule collector and integrated recovery systems technology is being developed by the Korea Research Institute of Ships and Ocean Engineering (KRISO), and lift technology is being developed by the Korea Institute of Geology, Mining and Materials (KIGAM). Joint research with other institutions, universities and industry in Korea and overseas have been encouraged and led to much progress during the initial stages. Much of the effort has now focussed on the mandatory relinquishment of 50% of the 150,000 km<sup>2</sup> of the Registered Pioneer site by 2002. Besides the intensive exploration effort to maintain a 5 km grid, the work includes studies on the environment in the area and its natural variability. Advanced exploration technologies being studied include high quality data acquisition, interpretation techniques, new technology applications, and cost-effective survey systems.

The work on exploitation technology has focused on systems needed for full commercial mining in 2010 or later and include feasibility studies, concept system design and design of selected primary subsystems. The Korean concept design is based on enhancement of existing subsystems which include a self-propelled collector with flexible umbilical, enhanced buffer functions, and a conventional lift system. Innovative computer modelling has been extensively utilised in the design of the collector vehicle, pick-up device, two and three phase lift technology, mining operations, buffer position control, dynamic positioning and route tracking for the

mining vessel, and dynamic simulation of the vessel and the tracked vehicle. Future plans are to increase international cooperation in the development of a commercial mining system and the government is planning a second long-term programme to this end.

The paper was very informative and the discussion was limited to a few questions regarding involvement of the private sector, the environmental effects of the water jets, and the purpose of external thrusters on the collector frame, all of which were effectively answered by the speaker.

### **Involvement of the private sector**

Asked how the involvement of the private sector affected the Korean national programme, Mr. Hong responded that at the beginning of the project Hyundai Heavy Industry (HHI) was involved in the research programme through the Hyundai Maritime Research Institute (HMARI), a research organization of HHI. This participation of the private sector continued for three years in the first phase of the national project, but in the second phase it was discontinued. It was unfortunate because the joint development of the hybrid pick-up device by Hyundai and KRISO had then stopped. In the first phase of this deep seabed mining project only Hyundai was involved.

### **The hybrid collector water jet**

There was a question as to whether the hybrid water jet, in loosening the nodules, suspends less sediment than a mechanical device. The speaker did not mean exactly that, he said. In the hybrid design, water jets loosen the nodules, lift them up a little and transport them in the sediment plume. Only the nodules would be caught up by the mechanical conveyor but there would still be a considerable plume because of the water jetting; probably more than if there was just a plain, simple mechanical scraper. The transportation of plume sediments to the surface, however, is low.

### **Collector thrusters**

The speaker explained that what appeared to be thrusters on the collector were used during the launching process to control movement or rotation of the collector.



## Chapter 13

### AN OVERVIEW OF INDIAN POLYMETALLIC NODULE PROGRAMME

*Prof. M. Ravindran,  
Director, National Institute of Ocean Technology  
Department of Ocean Development, Government of India Chennai, India.*

**Preamble**

**Survey and Exploration**

**Mining Technology**

**Extractive Metallurgy**

**Environmental Impact Assessment**

**Concluding Remarks**

**Summary**

## PREAMBLE

The polymetallic nodule programme is one of the major R&D efforts in India towards the development and use of Ocean Science & Technology for the exploration of the marine non-living resources for the socio-economic benefit of the society. This multi-disciplinary programme is being executed by multi institutional participation. On 26th January, 1981 the Indian Oceanographic Research Vessel 'Gaveshni' collected the first sample of polymetallic nodules from the Indian Ocean.

Continued Indian efforts succeeded in identifying a prospective site with polymetallic nodules in the Indian Ocean and recognition of India as a pioneer investor in 1982. Subsequently, India became the first Registered Pioneer Investor in August 1987 along with Japan, France and the Soviet Union (now Russia).

Today, India is the only country with a mine site allocated in the Central Indian Ocean Basin while all others are in Pacific Ocean. In this programme, survey and exploration, mining technology, extractive metallurgy, and environmental impact analysis are the four areas where the Indian efforts are directed. An overview of the progress and the future plans in these areas is briefly presented.

## SURVEY AND EXPLORATION

The major component of the Indian polymetallic nodule programme is survey and exploration. India has made considerable progress in resource identification, assessment, associated technology and manpower development. Initial efforts were directed towards fulfilling the requirements under the UN Convention for registration as a pioneer investor. For this purpose, identification of two areas of equal commercial value, one of which was the reserved area and the other the pioneer area in the Central Indian Ocean Basin was required. India was thus allotted an area of 150,000 sq. km. where pioneer and site specific activities are being carried out.

During the past 15 years, systematic grid sampling and surveys were taken up in a phased manner with definite objectives. The surveys were carried out onboard the Indian Research Vessels Gaveshni and Sagar Kanya supported by chartered vessels Skandi Surveyor, Farnella, GA Re ay, Nand Rachit, and Sidorenko. Over 4 million sq. km of area was explored and more than 10,000 locations were sampled for nodules, using sampling devices such as free fall grabs, corers etc.

Multi-beam bathymetric surveys onboard Sagar Kanya replaced the initial single beam echo soundings. The vast data, thus acquired, provided new insights on the topography of the basin and the resource potential. Recently, deep-tow pho-

tographic surveys were conducted on pre-selected tracks to get visual observations and confirm the techniques for resource estimation. Based on these surveys the resource potential in abundance and quality was estimated.

India has already relinquished 20% of the Pioneer Area as per the stipulations of Resolution II of UNCLOS III and has recently communicated to the International Seabed Authority an additional 10% of the area for relinquishment. Further, it is planned to carry out during July and September '99, close grid surveys at 5 km x 5 km and deep-tow photography in selected areas to improve the estimates on resource potential and demarcate the mine site and mining tracks.

## MINING TECHNOLOGY

Polymetallic nodules from the Indian mine site were earlier collected using the conventional dredging systems. Design & development of a remotely operated underwater mining system with collector module, lifting module and instrumentation and control systems, was initiated in 1990 at the Central Mechanical Engineering Research Institute (CMERI), Durgapur. Initial efforts were to test the concepts and generate some of the basic data and to understand the functional and operational needs of the system and its subsystems. The underwater mining system with a capacity of 100 tonnes/day had a remotely operable crawler based collector module, a bucket-in-pipe based lifting module and control module with required instrumentation. The performance of the subsystems was evaluated on land and subsequently on-shore shallow test basin. Consequently, the development of a remotely operated vehicle (ROV) for inspection and maintenance of the underwater systems was also undertaken. The performance of the ROV is being evaluated off the Indian Coast.

The collector module for the seabed mining system consisted of a crawler vehicle, a mechanical screw type collecting head, a bucket elevator to transport the nodule to the hopper, a crusher to size the nodules and a pump to transport the nodule-water mixture to the riser module.

The crawler vehicle had two independently-run tracks, powered by two rotary-vane-type hydraulic motors run by a variable-displacement-type axial piston pump. The collecting head had two screw conveyors to sweep the scattered nodules lying on the sea bed and converge them below the elevator so that they could be scooped up to the crusher via the hopper. The crusher had two rotary drums in which the nodules were crushed to the size of 10 mm and below. The crushed nodules were then fed to the riser module through a flexible pipe. The integrated mining system was evaluated for performance in 5 m depth water in a specially constructed shallow basin.

Further development of this complex deep-sea mining technology has been planned with multi-institutional and multi-national participation to derive the maximum benefit of the existing technologies, resources and potential even outside India. For this purpose, India is currently working on a joint developmental programme on deep-sea nodule mining technology with the participation of the National Institute of Ocean Technology (NIOT), Chennai, a technical arm of the Department of Ocean Development. As an intermediate technology demonstration, the major subsystem of deep-sea mining, is being proven in shallow water mining of sand at 500m. For this purpose the crawler available at the University of Siegen is modified with a sand mining system, a manipulator, pumping system and other accessories for demonstrating the shallow bed mining technology in Indian Seas.

The basic crawler itself is designed for operations up to 6000m water depth and the involute profile of the rubber tracks compacts the seabed and minimizes the disturbance to the sediments when the crawler moves along the sea bed. After two preliminary tests in 60m and 120m depth, during October 1998 and April 1999, the final sand mining is expected to be demonstrated by October 1999. The phase I of this joint programme between India and Germany will also prepare a design report on the total mining system for 6000m depth by December 1999.

In sea bed mining a number of subsystems are operating at different depths. For uninterrupted operation and prolonged service life of the Underwater installation and equipment, it is necessary to inspect them on a routine basis and carryout maintenance operations. In 1993, CMERI started the development of a Remotely Operated Vehicle (ROV) for visual inspection of selected areas. Its special features included a multifunctional manipulator of five degrees of freedom and about 5 kg payload.

After successful completion of further tests at deep waters it is planned to modify this ROV to support the proposed shallow mining system development. Manned and unmanned submersibles capable of operating up to 6000m depth are useful for deep-sea mining technology development. Considering the immense applications of the ROV for other underwater programmes in addition to seabed mining, a joint development programme between Experimental Design Bureau of Oceanological Engineering (EDBOE), Moscow, and NIOT has been proposed. This is expected to be approved by the respective governments shortly. The extension of this design to 6000m is both very complex, time consuming and expensive.

## **EXTRACTIVE METALLURGY**

Copper, nickel, cobalt and compounds of manganese are the major metals of interest from polymetallic nodules. In 1984, a few national laboratories and Indian

industries started the R & D for recovery of 3 metals (copper, nickel, cobalt) from the nodules mined from the Indian Ocean. After studying and analyzing the merits of about 15 process routes, India chose the hydrometallurgical option.

In the late eighties, the three institutions, Regional Research Laboratory-Bhubaneswar, National Metallurgical Laboratory - Jamshedpur and Hindustan Zinc Limited - Udaipur intensified the process development efforts through ammonical sulphur-dioxide leach route, roast reduction ammonical-leach route and acid leach - pressure leach route respectively.

In early 1997 the result of the batch scale process development were reviewed with the assistance of Indian consultant M/s. Engineers India Limited, New Delhi. It was decided to develop the sulphur-dioxide ammonical leaching process further in a continuously operating pilot plant with a capacity to process 500 kgs dry nodules per day and continuously for 40 days. In this process copper, nickel, cobalt are leached from the nodules by sulphur-dioxide and ammonia. About 30% of manganese is recovered as manganese-dioxide and the rest as residue.

From the leached solution, copper is extracted as metal. After copper extraction, a sulphate solution of nickel and cobalt along with zinc impurity are prepared. Subsequently, nickel and cobalt are recovered as metal from the sulphate solution. From the residues the remaining manganese is extracted as ferro manganese alloys.

The continuously operating pilot plant is being established at M/S. Hindustan Zinc Limited, a metallurgical Industry at Udaipur. About 100 tonnes of the nodules shall be processed in five batches to optimise the process parameters and to generate required data on process parameters for designing large scale commercial plants.

## **ENVIRONMENTAL IMPACT ASSESSMENT**

In order to assess the impacts of large scale deep seabed mining activity on the marine environment a long term EIA study is undertaken. The EIA study is executed in three phases. In the first phase baseline oceanographic data on the seabed as well as water column in respect of physical, biological, meteorological, chemical and geological parameters from the Indian mine site at Central Indian Ocean Basin (CIOB) was collected during 1996 and 1997 using 3 cruises onboard RV Sidorenko and 1 cruise onboard ORV Sagar Kanya. In addition, as a part of time series baseline oceanographic data collection, three mooring systems were deployed in pre-selected locations in CIOB mine site for a period of about 200 days. Based on the result of these studies, two identical sites one called 'reference site' and the other 'test site' of about 10 x 10 nautical miles each were demarked for conducting the detailed EIA study.



On the basis of the analysis of specimens collected in different pre-selected stations and the interpretation of observed data, nodule distribution, seafloor bathymetry, sediment thickness, megabenthic activity, porewater chemistry, solid phase sediment, chemistry size analysis and associated sediments, geo-technical properties of sediments bio-stratigraphic analysis, quantitative distribution of benthos, microbial life and bio-chemical composition, particle fluxes were assessed.

In the second phase, the benthic ecosystem on designated site was disturbed by a specially designed hydraulic disturber which was towed 26 times along the disturbance site of 3 km x 0.20 km for a total disturbance duration of 47 hours and 30 minutes, and thus resuspending an estimated 3600 tonnes of sediment in 9 days. The distribution and re-settlement of these particles, the changes in sea floor features as well as the impact on the benthic environment due to these activities were studied using a variety of sampling and survey techniques including deep tow photography, CTD sampling and mooring systems onboard R V. Yuzhmorgeologia during June-August 1997.

Before the disturbance of the seabed, 5 navigation transponders were deployed and calibrated. Photographic and sonar surveys were conducted over the selected area to know the seabed disturbances in addition to 20 box cores and one multiple core samples of sediments, three CTD and rosette observations and 10 mooring systems with sediment traps and current meters with transmission meter to evaluate the extent of sediment resuspension and distribution. The preliminary results of pre and post disturbance sampling suggest that although the sediment plume is not seen in the water column within few days of disturbance, the impact on seabed is visible in the disturber tracks and resedimented areas.

The next phase consists of monitoring parameters in and around the disturbed area to assess the damage to the benthic ecosystem and its recolonization. In order to undertake the above tasks, 2 cruises are scheduled currently in July 1999 and September 1999 followed by yearly monitoring in the 'test site' and 'reference site' to monitor the recolonization and restoration of the original benthic organisms. The results of this study will be useful to predict the impact of large-scale mining and in regulating nodule mining operations to avoid undesirable damage to the marine environment. The EIA study is being carried out at National Institute of Oceanography, Goa in technical cooperation with Central Marine Geological & Geophysical Expedition, Gelendzhik, Russia under an MOU between Department of Ocean Development, Government of India and the Ministry of Natural Resources, Government of Russian Federation.

## **Concluding Remarks**

The techno-economic viability of a polymetallic nodule programme for exploiting the ocean bed for metals for industrial use is not yet established. The commercial viability depends on the advances in technologies, market demand, availability of land-based resources etc. India has planned the development programmes in a phased manner in different technical areas with multi-institutional participation including industries. The major thrust is being given to have innovative designs of the subsystems of the deep-sea mining complex so that the cost of the system could be reduced and reliability increased. This will also lead to achieving commercial mining of nodules at lower output levels.

The present technologies shall be developed to the level from which it could be scaled up or upgraded for a commercial venture when economic feasibility is established.

## Summary of the presentations and discussions on an overview of the Indian polymetallic nodule programme

On behalf of Professor M. Ravindran, Director of the National Institute of Ocean Technology in Chennai, INDIA, His Excellency Mr. B Gupta, High Commissioner of India to Jamaica presented An Overview of the Indian Polymetallic Nodule Program. Mr. Gupta informed the workshop that the Indian polymetallic nodule programme is one of the major R&D efforts in India, directed toward the development and use of marine non-living resources for the socio-economic benefit of the society. In 1981 the first samples of nodules were collected from the Indian Ocean, beginning a program that resulted in India's recognition as the first Registered Pioneer Investor in 1987, along with Japan, France and the Soviet Union.

Indian efforts are directed in four areas: survey and exploration, mining technology, extractive metallurgy, and environmental impact analysis. India has already relinquished 20% of the area and has another 10% ready.

Close grid surveys at 5 km spacing are now planned to demarcate the mining areas and to estimate the resource potential. Mining technology has been advanced on a model scale and a remote crawler system with a crusher and hydraulic transport for 100 tonnes/day has been built and tested in shallow water.

More recent joint activities with the University of Seigen, in Germany have resulted in the design of a superior mining system which will be tested in deeper water. The system was earlier described by Professor Schwarz. As early as 1984, studies were begun on the recovery of copper, nickel and cobalt from nodules found in the Indian Ocean. After studying about 15 processing options, the hydrometallurgical method was selected as the most appropriate. Subsequently this was again narrowed to the development of a sulfur dioxide ammonia leach. A continuously operating plant is now being established by Hindustani Zinc at Udaipur.

On the environmental side, a long-term study was undertaken in three phases in the Central Indian Basin. The first was a baseline study, the second an imposed disturbance using a hydraulic disturber, and the third a time-related study of the impacts on the ecosystems disturbed. The speaker indicated that the viability of industrial operations in terms of technology and operations is not yet estab-

lished and major emphasis is now being given to innovative design that will reduce costs and increase reliability.

The paper was well received and there were no discussions following the presentation.





## Part III

### Opportunities for Increasing the Global Mineral Resources Base from Marine Mineral Development

<b>Introduction</b>	296
<b>Chapter 14 Atlantis II Deep: A Future Deep Sea Mining Site</b> <i>Dr. Zohair Nawab, Ministry of Petroleum and Minerals, Saudi Arabia</i>	301
<b>Chapter 15 Terrestrial Mines in the Sea; Industry, Research and Government</b> <i>Mr. Julian Malnic, Chief Executive, Nautilus Minerals Corporation, Australia</i>	315
<b>Chapter 16 Methane Hydrate Research and Development in the United States</b> <i>Dr. Michael Cruickshank, MMTC Associates, Honolulu, Hawaii. USA</i>	333
<b>Chapter 17 New and Proven Mining Systems for Placer Deposits on the Continental Shelf</b> <i>Dr. Richard Garnett, President, Valrik Enterprises Inc., Canada</i>	345

## Introduction

Since 1958, when Dr. John L. Mero, a mining engineer at the Hearst School of Mines in the University of California, Berkeley, first published an economic discourse on the vast potential of deep-seabed polymetallic nodules as sources of manganese, cobalt, copper and nickel, these marine mineral resources have dominated the imagination of the international community. The primary forum for discussions on these resources was the Third United Nations Conference on the Law of the Sea, where decisions on a legal framework for developing these resources were incorporated in Part XI of the United Nations Convention on the Law of the Sea.

With rapidly expanding scientific knowledge of the Earth and its oceans, the current vision of marine minerals has changed significantly. At the time of Dr. Mero's paper on deep-seabed polymetallic nodules, ocean basins were considered passive containers of the oceans. According to this view, marine metal, non-metal and non-fuel minerals were considered to be primarily derived by the erosion of continental rocks and transported into the ocean by rivers in solid (sediment) or dissolved phases. This view adequately explained the marine minerals known at the time. Within this framework, the marine minerals that were transported as sediments, under this view, resulted in formation of beach and placer deposits of various heavy minerals containing metals (gold, tin, titanium, iron, barium, chromium and others), and non-metals (diamonds, silica and lime). Similarly, the input of dissolved materials into the ocean by rivers was considered an adequate source to form several mineral resources for the future. These resources were thought to comprise polymetallic nodules, cobalt-rich ferromanganese crusts, and phosphorite deposits that precipitate from seawater.

With the advent of the theory of plate tectonics in the 1960s, the view of ocean basins has changed from passive to active containers of the oceans. As a result of the theory of plate tectonics, it is now known that hot molten rocks well up beneath a submerged volcanic mountain range that extends through all the ocean basins of the world. The molten rocks cool, solidify, and create two conveyors of seafloor that move at a rate of centimeters per year to either side of the submerged mountain range in the process of seafloor spread-

ing. As cold, heavy seawater flows down several kilometers through the volcanic rocks that underlie the seafloor, it is heated where it flows near the hot rocks beneath the submerged volcanic range. The heated water expands and buoyantly rises, dissolving metals present in small quantities in the volcanic rocks and concentrating the metals (copper, iron, zinc, silver and gold) as massive seafloor sulphide deposits beneath and on the seafloor at sites of hot springs along the submerged volcanic mountain range (water depths 1 to 4 kilometers). At this early stage when only about 5 percent of the seabed has been systematically explored, about 100 such sites have been found along the submerged volcanic island chains such as those that border the western margin of the Pacific Ocean.

In 1965, during a research cruise of the RV Atlantis II of the Woods Hole Oceanographic Institute in the Atlantis II deep of the Red Sea, it was discovered that the bottom of the deep contained mineral-rich mud with grades of about 0.45% copper, over 2% zinc and over 38 grams per ton of silver. Further exploration of these deposits which occur at about 1,990 meters depth in the Red Sea revealed a deposit with a metal content assessed at 1.8 million tonnes of zinc, 3,432 tonnes of silver and 404,000 tonnes of copper. Chapter 14, contained in this part of the proceedings, contains a presentation and discussions on "The Atlantis II Deep: A Future Deep Sea Mine Site", a paper prepared and presented by Dr. Zohair Nawab of the Ministry of Petroleum and Minerals of Saudi Arabia.

In 1979 the first discovery was made of active hydrothermal deposition of metalliferous sulphides at a spreading oceanic plate boundary in deep water near the Galapagos Islands. Carrying potentially economic values of copper, lead, zinc, gold, and silver, in rock chimneys and coalesced mounds associated with mineral rich waters, venting from the seabed in black plumes at 350 degrees Celsius, these deposits immediately caught the attention of scientists and minerals specialists. It was quickly noted that the deposits were similar to those discovered in the Red Sea fifteen years before, but with two significant differences. They were discovered on the exposed rock surface of spreading plate boundaries, which formed some 60,000 km of virtually unexplored mid-ocean ridges at depths of 2,000-3,000 m throughout the world's oceans. If protected by being formed at depth in the bedrock, or by being covered by impervious sediment or basalt flows, they would be carried in the seabed across the ocean floor on both sides of the ridges until destroyed or subsumed at the next subduction or collision boundary. The possibility of discovery of mineral deposits anywhere in the world's oceans was assured. The other difference was the association of these hydrothermal sites with previously unknown, sulphur-based life forms that lived around the superheated, high pressured, anoxic environment of the vents.



To the life-scientists and geneticists, this serendipitous discovery was a breakthrough of significant proportion. Although less than five percent of the ridge systems has yet been explored, over 50 mineralized vent fields have already been located and like all mineral deposits, no two are alike.

Recent discoveries of high-gold-bearing massive sulphides in the archipelagic waters of Papua New Guinea resulted in the issuance of exploration licenses in 1998 and set off a chain of exploration activities elsewhere. Chapter 15 contains a summary of the discussions following the presentation of the paper "Terrestrial Mines in the Sea, Industry, Research and Government". The paper was prepared and presented by Mr. Julian Malnic, Chief Executive Officer of Nautilus Minerals Corporation, the company that was awarded the exploration licenses in the exclusive economic zone of Papua New Guinea.

The discovery in the late sixties of extensive deposits of metalliferous oxide crusts, similar in composition to manganese nodules but higher in cobalt, resulted in the recognition of other such deposits throughout the Pacific on sea mounts and the slopes of islands in the depth range of 800-2400 meters. Serious examination of these cobalt crusts is continuing in a number of countries. Deposits of phosphorite, a major fertilizer material, have similarly been found in wide-spread locations in the major oceans as well as enormous deposits of carbonate and siliceous sands of commercial purity, but no serious exploration for these types of deposits has been completed. In the last few years, deep-water petroleum resources have been located in depths to 4000 meters and beyond in areas well seaward of previously anticipated discovery. These activities have led to renewed interest in natural gas hydrates, not only because they are a potential hazard to deep-water petroleum operations, but also, as it turns out, because they represent a potential energy resource of almost unbelievable dimensions. Dr. Michael Cruickshank, President of MMTC Associates in the United States, prepared and presented a paper at the workshop. His presentation and the discussions that took place on "Methane Hydrate Research and Development in the United States" are contained in chapter 16.

One of the results of this major change in direction for ocean minerals has been a very significant effort to develop improved technology for the exploration of the deeper seabed. Undoubtedly a major contributor to these advances has been the deep-water petroleum industry whose capabilities are fast approaching the needs of the future producers of nodules, sulphides, crusts, hydrates, and deep-water sands. Equally important have been the advances in mining technology, robotics and underwater exploration now being used on a routine basis by mining engineers in the shallower, but sometimes, more violent waters of the continental shelf for the production of construction aggregates, gold and diamonds to depths of 400 meters.

The International Seabed Authority has been engaged in the formulation of Rules, Regulations and Procedures for the exploration for polymetallic nodules beyond the limits of national jurisdiction. Once adopted by its Assembly, it is expected that the Authority will issue seven contracts to the registered pioneer investors. Key aspects in the development of this industry will be reserve estimation, technology development and, during mining, mineral recovery performance. A major contributor in the non-metal, non-fuel marine minerals industry has been diamond mining. Dr. Richard Garnett, President and CEO of Valrick Enterprises, presented three papers at the workshop on: "New and Proven Mining Systems For diamond Deposits on the Continental Shelf"; "The Estimation of Offshore Diamond Reserves", and "Mineral Recovery performance in Offshore Diamond Mining". His paper on "New and Proven Mining Systems for Diamond Deposits on the Continental Shelf" and summaries of his presentations and the discussions that followed are contained in Chapter 17.

In the last 30 years there have been some very significant changes in this world and the way it may be perceived. It has now become common knowledge that the globe is three-quarters covered with water. It is not so common knowledge perhaps, that the potential mineral resources of the sea-beds under those three-quarters of the globe are, hectare for hectare, equivalent in value to the mineral resources on the terrestrial lands. If we accept that, then the total of global mineral resources has been quadrupled, by just that one concept. Furthermore, the seabed of the Pacific basin and rim alone equal half of the world's surface area. Of this seabed, half of them are in Exclusive Economic Zones of countries in that region while the other half are in areas beyond the national jurisdiction of any state. The development of these resources is going to significantly affect the future economies of the world with regard to mineral resources and their natural environment.



## Chapter 14

### ATLANTIS II DEEP: A FUTURE DEEP SEA MINING SITE

*Dr. Zohair Nawab<sup>1</sup>*

*Ministry of Petroleum and Minerals, Saudi Arabia*

**Location**

**Exploration History**

**Geologic Setting**

**Deposits Description**

**Pre-Pilot Testwork**

**Assessment**

**Summary**

---

<sup>1</sup> Dr. Nawab joined the Ministry of Petroleum and Mineral Resources as a staff geologist in 1968 and was a lecturer at King Abdulaziz University, Jiddah, 1973-78. He was Deputy (later Acting Secretary General of the Saudi-Sudanese Red Sea Commission 1978-88. From 1988-94 he was the Director of Planning. He is now Geological Advisor (P.O. Box 345, Jeddah 21191, Kingdom of Saudi Arabia).

## LOCATION

The Atlantis II Deep (21°23'N., 38°04'E.,) lies in the axial trough of the Red Sea approximately mid-way between the Kingdom of Saudi Arabian and Sudanese coasts almost due west of Jiddah. The bottom of the deep contains mineral-rich mud at a maximum water-mud interface depth of 2,149 m.

## EXPLORATION HISTORY

The announcement of the discovery of mineralized muds in the Atlantis II Deep at a meeting of the International Oceanographic Commission in Paris in July 1965 sparked exaggerated speculation concerning the value of the contained metals. However, it also created an awareness among those states bordering the Red Sea of the possible economic significance of such off-shore mineral resources, and this stimulated further exploration. (Table 1).

Table 1. History of exploration, Atlantis II Deep

1965	Deep discovered during voyage of R.V. Atlantis II, of the Woods Hole Oceanographic Institution.
1966	Core samples recovered by R. V. Chain indicated economic potential of Atlantis II Deep to exceed \$2.5 billion.
1974	Agreement between Saudi Arabia and Sudan to jointly carry out exploration and development
1975	Formation of Saudi-Sudanese Joint Red Sea Commission
1976	Geophysical exploration by the Joint Commission of submarine area between Saudi Arabia and Sudan.
1976-8	Initial studies by the Joint Commission on technology for mining mud from Atlantis II Deep and extracting the contained metals.
1979	Pre-pilot plant testwork

By mid-1973, it had become apparent that potentially exploitable deposits of mineralized mud were to be found along the axial trough of the Red Sea between the Kingdom of Saudi Arabia and the Democratic Republic of Sudan, and the two countries began negotiations to establish the legal framework for combined investigation of the non-living resources of the area. These negotiations led to an "Agreement for the Joint Exploration of the Red Sea Natural Resources in 1974" (fig. 1), and the formation of the Saudi-Sudanese Joint Red Sea Commission in 1975.

The Commission was charged with the task of exploring the Common Zone, the area lying below the 1,000 m bathymetric contour forming the axial trough between the two countries, and conducting the research necessary to estab-

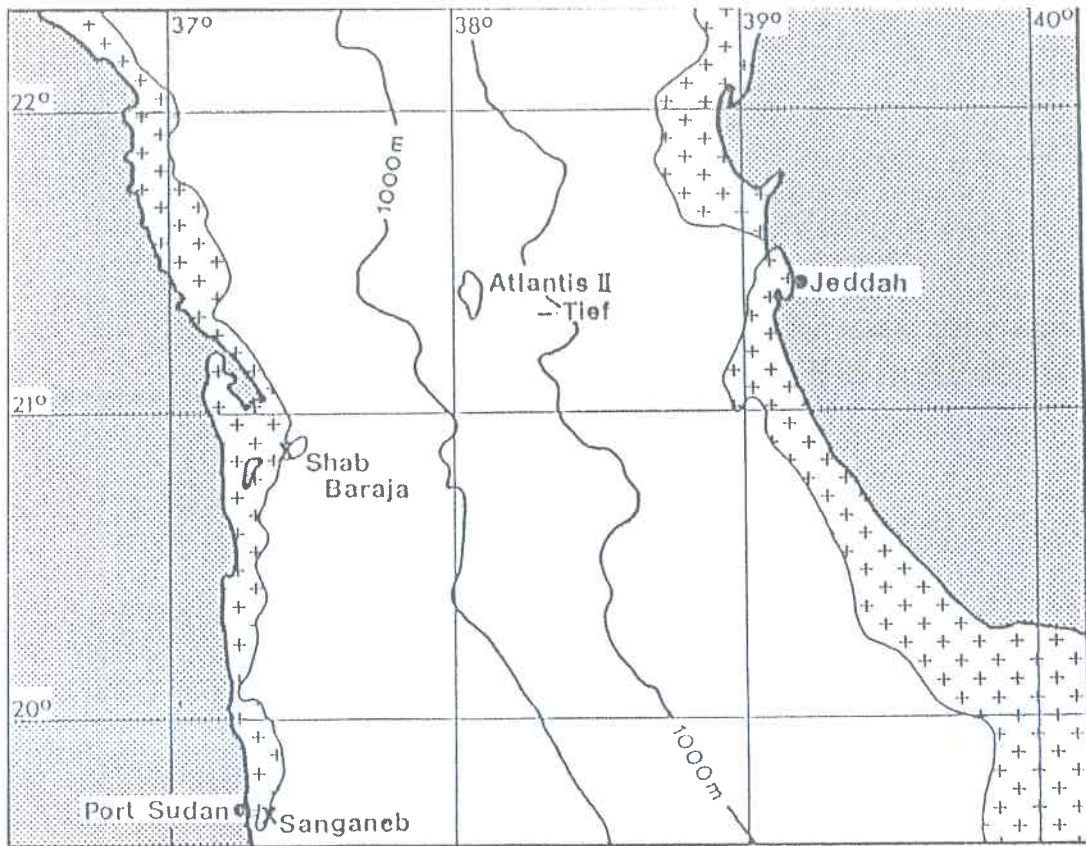

Figure 1- Red Sea commission joint area is = 1000 meter of water depth

lish the economic and technical feasibility of exploiting the metalliferous muds. The Commission appointed Preussag AG as its principal contractor and BRGM as its technical consultant.

Geophysical surveys (airborne magnetometry, marine gravimetry, and deep reflection seismic profiling) over the area between the Saudi Arabian and Sudanese coasts resulted in a refined interpretation of the regional structure of the Red Sea trough. Three systematic coring programmes provided data to determine the geology of the Atlantis II deposits, which is, by far, the most promising of the known occurrences of mineralized mud, and to estimate its resources. High resolution-seismic and echo-sounding techniques were used to investigate the configuration of the deposit. Prospecting was undertaken in conjunction with an environmental research programme, which included oceanographic surveys and biological studies, to obtain data to determine the effects of deep-sea mining on a delicately balanced ecosystem within an almost enclosed and relatively unpolluted sea.

## GEOLOGIC SETTING

The Red Sea began as a marine area in the miocene, when evaporite and sedimentary beds were deposited between the Arabian and Nubian shield blocks. Two views are held on the formation of the Red Sea: one that the two shield blocks became separated by sea-floor spreading starting in the early miocene, leading to the formation of new oceanic crust; the other that a submarine depression was created at that time by down-warping and rifting of the proterozoic rocks between the present shield blocks. A compromise, and more probable solution is that both mechanisms contributed to the formation of the Red Sea and that continental basement flanks new oceanic crust beneath the Miocene strata (fig. 2).

At about the mid-pliocene, an axial trough began to open along the center of the Red Sea, which now forms a depression more than 1,000 m deep and 15-40 km wide underlain by new oceanic crust. Subsequently, probably in the holocene, a number of deeps opened along the middle of the axial trough.

One of these deeps, Atlantis II, contains hot brine above mineralized mud. The mud ranges in thickness from several meters on the central sill and marginal slopes to about 30 m in the west basin area,

The mineralized mud was formed by chemical precipitation from inflowing hot brines and subsequent sedimentation. The timing of brine activity and mineralization appears to be related to glacio-eustatic changes in sea level. Elevations in sea level at the end of glacial periods (late Pleistocene) probably promoted the movement of sea water along fault zones and resulted in discharge of brines within the axial trough.

### Deposits Description

The outline of the deep at the 1,990 m isobath, is approximately a parallelogram (fig. 3) with sides 12 km long parallel to the axial trough of the Red Sea, and 5 km wide parallel to a system of transform faults that cuts across the trough. The floor of the deep is irregular and is interrupted by a central sill that in places protrudes through the surface of the mud.

The bottom of the deep is filled to a maximum depth of 30 m by metal-rich mud consisting of ultra-fine-grained (80 percent less than 2 microns) mineral particles and brine. The composition of the mud shows marked lateral and vertical variations and five vertical lithostratigraphic zones have been distinguished (table 2). The brine content decreases with depth, the muds changing from a semi-liquid at the top of the deposit to a near-solid state having the consistency of boot polish near the bottom.

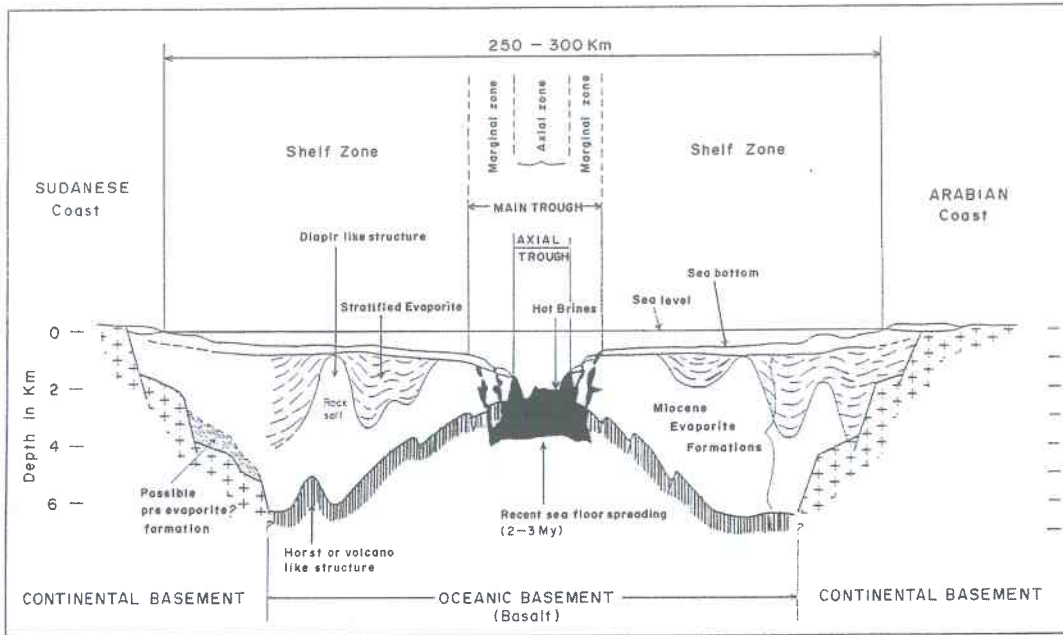

Figure 2 - Schematic geological cross section in the Central Red Sea

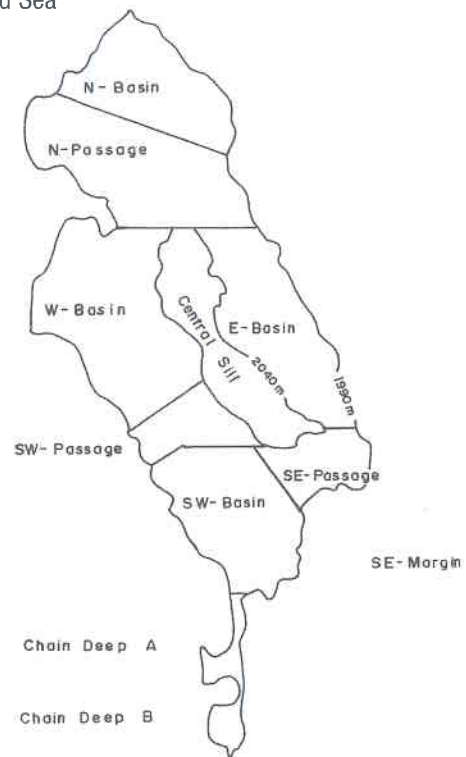

Figure 3 - Morpho-sedimentological units of Atlantis II Deep



A pool of hot brine (40-62°C) 200 m deep overlying the mud is layered and varies in character with time. Temperatures and facies variations within the sediments indicate that brine is being exhaled through the sediments under the southwestern portion of the deep. The brine is thought to be recycled water released from the Miocene sediments that flank the axial trough, and carrying metals dissolved from these sediments or from the basalt that forms the floor of the axial trough.

Table 2 Lithostratigraphic units of the Atlantis II Deep

Zone	Thickness in meters	Comment
Amorphous silicate (AM)	3-4	Semi-liquid, greenish to brown
Upper Sulphidic (SU <sub>2</sub> )	About 4	Contains Zn, Cu, Pb, Ag sulphides, grayish purple
Central oxidic (CO)	1-11	Mostly limonite, vivid red and orange
Lower sulphidic (SU <sub>1</sub> )	2.5-4	As Su <sub>2</sub>
Detrital-oxidic pyrite (DOP)	1.3-6	Intercalation of sulphides and oxides

The five vertical lithostratigraphic units vary in thickness and composition. They are identified (from top to bottom) as the amorphous silicatic zone (AM), upper sulphidic zone (SU<sub>2</sub>), central oxidic zone (CO), lower sulphidic zone (SU<sub>1</sub>), and detrital-oxidic-pyritic zone (DOP).

The SU<sub>1</sub> and SU<sub>2</sub> zones are richer in base metals than the other zones whereas the CO zone is almost without zinc or copper. In detail, the metal content varies considerably both laterally and vertically, but overall decreases significantly from south to north.

The extremely fine-grained nature of the muds makes identification of the minerals present extremely difficult. The most important minerals from a commercial point of view are sphalerite and chalcopyrite, but analytical data shows that a significant content of silver and a minor content of cobalt are also present. The gold content is low; it has not been systematically determined in core samples but has been recovered in bulk sulphide-flotation concentrates.

In terms of the value of recoverable metals, the deposit is best described as a zinc-silver-copper occurrence associated with minor cobalt and gold. Low contents of molybdenum, vanadium, and lead are present but are probably not commercially recoverable.

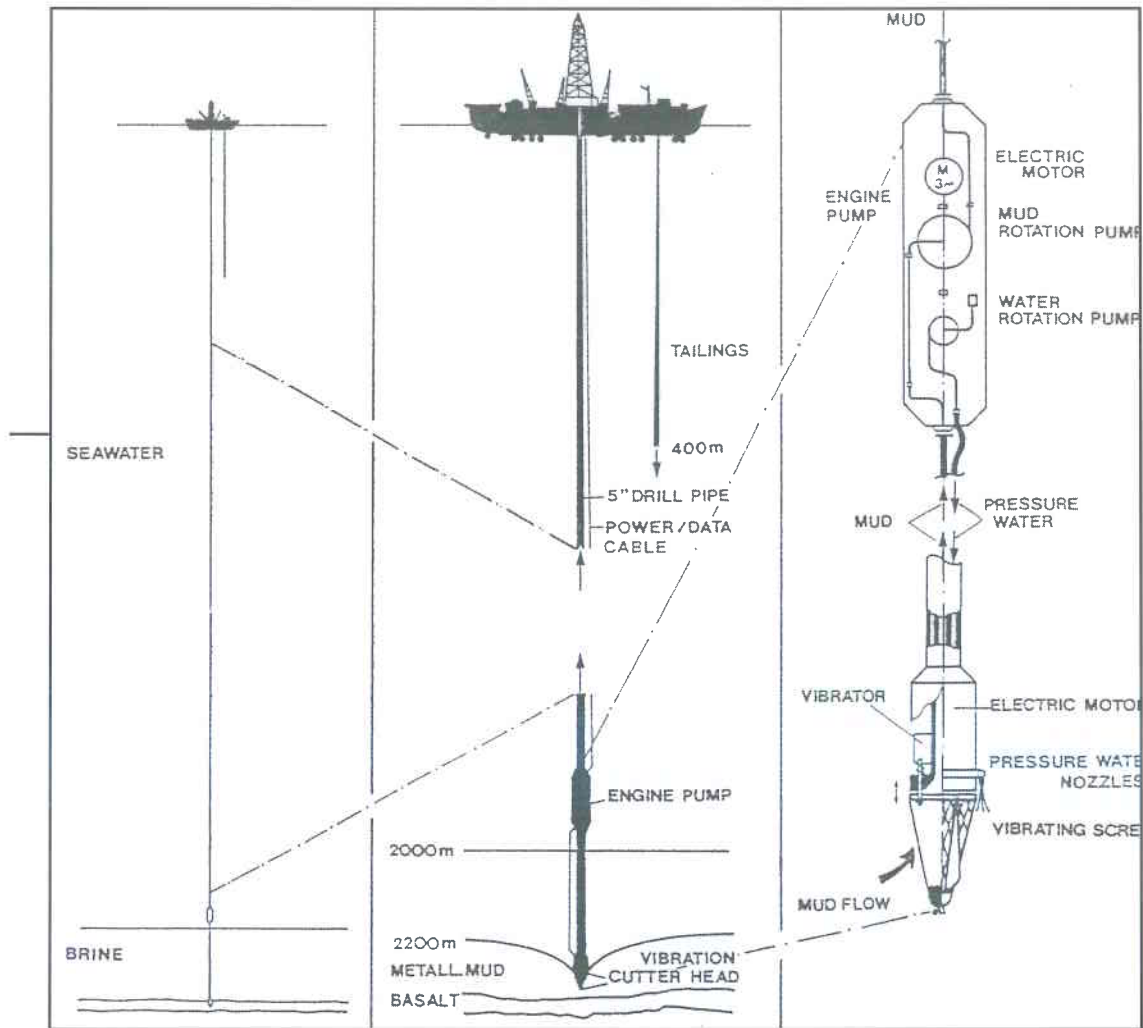

Figure 4 - General view of mining system

Gangue minerals include pyrite, iron hydroxides, manganese oxides, anhydrite, and silicates of the montmorillonite group. In addition to the minerals that were precipitated from the brines, the muds also contain fine-grained detritus.

### Pre-Pilot Testwork

The exploration programme with which the Commission was charged was unique. The technology to determine the reserves of an oceanic deposit at depths in excess of 2,000 m, to mine and beneficiate such fine-grained muds, and to process the resulting complex and brine-rich concentrate to produce

marketable products, did not exist. The Commission, therefore, sponsored studies to pump the mud to a floating platform to prepare a mineral-rich concentrate for transportation to the coast, and for the subsequent recovery of the contained metals.

The technology was tested on a pre-pilot scale in 1979, when 15,000 tons of hot brine-saturated mud, further diluted with sea water, was pumped to the surface. Four tons of concentrate containing up to 30 percent Zn, 4 percent Cu, and 600 g/t Ag was produced by flotation on board the floating platform, for which the Sedco 445 deep-sea drill ship was used. Grades of up to 40 percent Zn with recoveries of up to 70 percent were achieved. A schematic impression of mining arrangements is shown in figures 4 and 5.

Environmental studies were conducted throughout the pre-pilot test, with particular attention being paid to the behavior of the tailings. An assessment of all relevant data generated as a result of these and other studies indicated that there would be no unacceptable permanent damage to the environment as a result of commercial-scale operations provided tailings were discharged at a minimum depth of 1,000 m.

Several possible recovery processes were tested on a bench scale to determine the optimum route for recovery of the most valuable metals contained in the concentrate. The most promising route appears to be pressure-oxygen leaching and recovery of gold by precipitation on activated powdered charcoal: copper by solvent extraction and electrowinning: silver by precipitation of copper-lead silver on powdered zinc; and zinc by solvent extraction and electrowinning. Cobalt, cadmium, and gypsum could also be recovered in marketable amounts.

**Table 3: Resources of the Atlantis II Deep**

	Mud (a) Mt	Zn %	Cu %	Ag G/t
Demonstrated	89.5 ±4.6	2.06 ±0.12	0.45 ±0.02	38.4 ±1.8
Inferred	158.4	0.31	0.10	7.9
(a) dry salt-free basis				

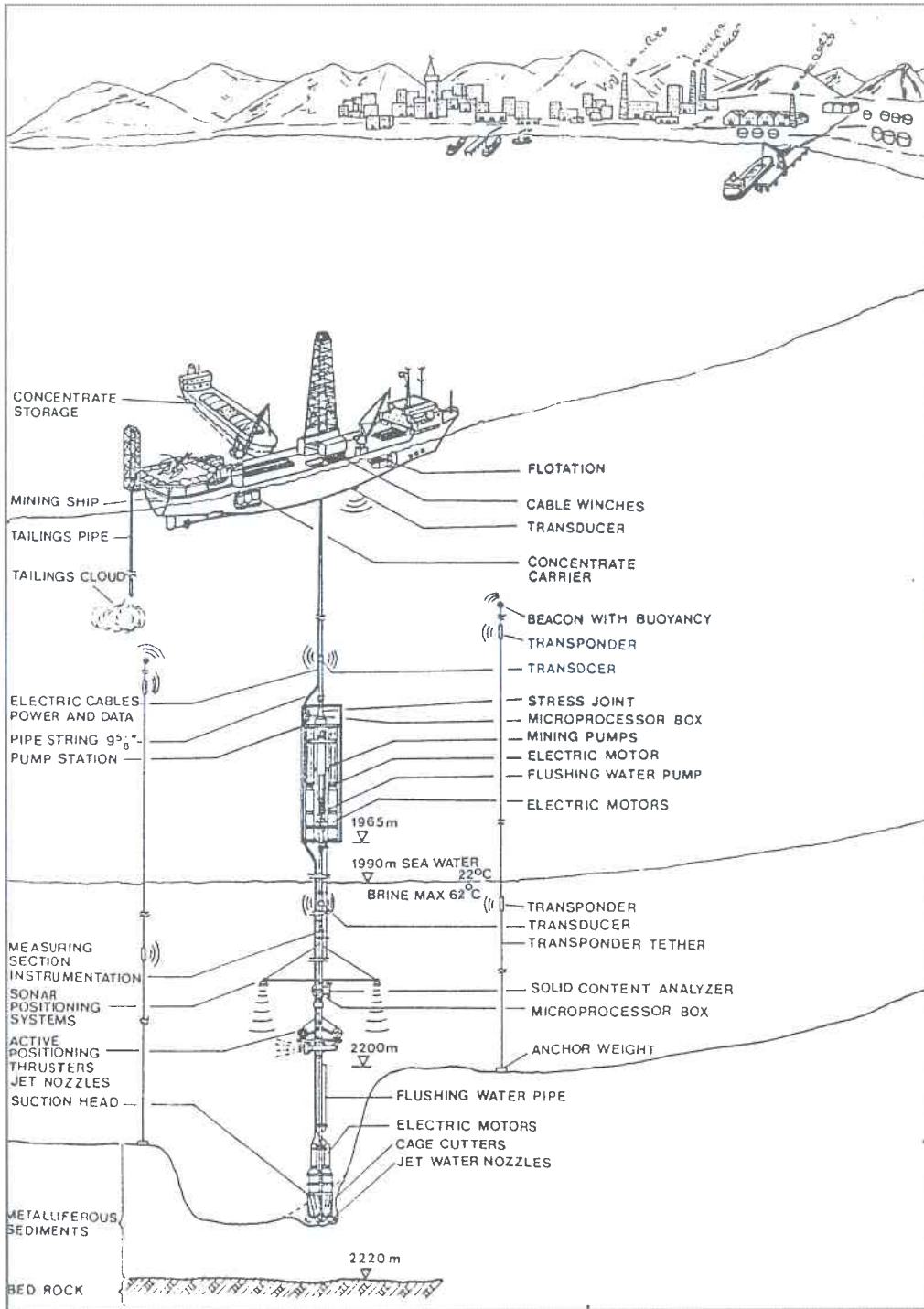

Figure 5 - General view of mining system

## Assessment

The resources of the Atlantis II Deep are summarized in table 3. The calculations are based on results from 605 cores, and two-dimensional kriging of 500-m square panels. Grades have been determined on a dry, salt-free basis, that is, the grade of the solid fraction of the mud. The demonstrated resources of the deposit in terms of the weight of contained metals are zinc 1,838,000 t, silver 3,432 t, and copper 402,000 t.

The results of the research undertaken by the Commission were utilized for the economic evaluation of possible commercial exploitation. The resources are considered adequate to support an average annual production of 60,000t of zinc, together with 10,000 t of copper, 100 t of silver and 1 t of gold, for a period of approximately 20 years. Metal prices current in 1982 would have resulted in a DCF of up to 17 percent depending on how the project was capitalized.

Proposals for pilot tests over a one-year period at one-tenth of the envisaged commercial scale of operations were submitted concurrently in 1982 by Pressag, BRGM, and the Research Institute of the King Fahd University of Petroleum and Minerals, Dhahran, but were not consummated.

## Summary of presentation of Atlantis II Deep: a Future Deep Sea Mining Site

*Dr. Zohair Nawab*, Geological Advisor, Kingdom of Saudi Arabia, spoke on the **Atlantis II Deep: a Future Deep Sea Mining Site**. Introducing his paper, Dr. Nawab said it was his pleasure to share, and discuss with the workshop, the experiment of the Saudi-Sudanese Red Sea Joint Commission on mining the metalliferous sediments from the bottom of the Red Sea. This experiment had been executed 21 years previously and he had had some involvement in the management of the project, representing the Kingdom of Saudi Arabia as Deputy Secretary General for the Commission.

The Atlantis II Deep lies in the axial trough of the Red Sea approximately mid-way between the Kingdom of Saudi Arabian and the Sudanese coasts almost due west of Jiddah. The bottom of the deep contains mineral-rich mud at a maximum depth of 2149 m. The site was discovered in 1965 during a research cruise of the RV Atlantis II of the Woods Hole Oceanographic Institute.

In 1975 the Saudi-Sudanese Joint Red Sea Commission was formed and continued actively through 1979 to carry out exploration and development on the deposit. Geophysical exploration and initial studies on technology for mining the muds were followed by a pre-pilot test perhaps best described as bulk sampling. The resources characterized amounted to about 90 million tonnes of mud containing 2.06% zinc, 0.45% copper, and 38.4 g/t silver, based on analyses of 605 cores, and two dimensional kriging of blocks of dimensions 500m square. The metal content was assessed at 1.8 million tonnes zinc, 3,432 tonnes silver, and 404,000 tonnes copper.

Environmental studies were an integral part of the test programme and the method to recover the extremely fine-grained mud and hot brine included water jetting and hydraulic pumping to a converted drilling vessel for dewatering, concentration and transport to shore for further treatment. Some 15,000 tonnes of hot, brine-saturated mud, further diluted with sea water, was pumped to the surface. The waste waters were discharged from the vessel at a minimum 1000 meters water depth.

Four tons of concentrate were produced by flotation in sea water on board the vessel and several recovery options were tested at bench scale on shore.

The most promising method was pressure-oxygen leaching with recovery of marketable amounts of gold, copper, silver, zinc, cobalt, cadmium, and gypsum from solution.

The resources were considered adequate to support a commercial operation for about 20 years and in 1982, the prevailing metal prices would have resulted in a Discounted Cash Flow (DCF) of up to 17%, depending on how the project was capitalized. Proposals for pilot testing at a one-tenth scale were submitted concurrently in 1982 by Preussag, BRGM, and the Research Institute of the King Fahd University of Petroleum and Minerals, Dhahran, but were not consummated.

The few questions focused on the layering of the deposit, the oceanographic environment and its effect on waste disposal, and the on-board processing of the muds.

### **Layering of the deposit**

In explanation of the many layers in the deposit, repeated sequentially like a major reversal, Dr. Nawab thought it was related to periodic hydrothermal activity that had continued, according to age dating, over a period of 10,000 years. It is now known from temperature monitoring that the hydrothermal activities in the Red Sea increase and decrease on a 4 or 5 year cycle and the different minerals layers are probably related to that, he said. Another comment on that question indicated that the same phasing can be seen taking place in the deposits in Papua New Guinea that have been studied. The late stages have a far greater oxidizing atmosphere in a typical cycle and, in fact, there is some debate whether that cycle can actually remove metals from the deposits and put them back into solution in the sea water.

### **A stagnant basin**

A unique thing about the Red Sea, the speaker said, is that it is very closed; there are no open areas. In a study of the currents for the whole water column it was found that below 800 m there was almost no current movement; it is a very stagnant place. Coming back after one year to find the tailings that were disposed of one year earlier, they were found confined to the grabben (steep depression) 10 km to the north of the mine site in the same place they had been deposited. There are no currents below a depth of 1000 m and it is believed that because of the salinity and the temperature, marine life at that depth is limited to bacteria. There has been no indication of any kind of other life there.

### **The largest deposit**

To their knowledge, and from all the exploration conducted in the Red Sea, the speaker indicated that the Atlantis II Deep is the largest, and that most of the metalliferous sediments are found in that area. There are different kinds of deposits in other areas; some have a lot of gypsum and a lot of sulphur and other compounds but the zinc, copper, lead, manganese, iron, cobalt, and nickel, to name a few of the 18 different elements found, are mostly concentrated in this deep.

### **On-board processing**

Processing onboard was a very successful operation. With sea water as the flotation medium it was possible to concentrate minerals of zinc, copper, lead, cobalt, nickel, gold, and silver in a bulk concentrate with a metal content of about 35-40%.





## Chapter 15

### **TERRESTRIAL MINES IN THE SEA; INDUSTRY, RESEARCH AND GOVERNMENT**

*Julian Malnic*  
*Chief Executive, Nautilus Minerals Corporation*

**A World First...**

**Emerging issues and new policy**

**The Importance of Research**

**The Rights of the Explorer**

**References**

**Summary**

## A WORLD FIRST...

In November 1997, my company, Nautilus Minerals Corporation became the first in the world to be granted exploration titles over the newly-discovered, high-grade seafloor massive sulphide (SMS) type deposits. Our announcement attracted widespread media attention including a large article on the front page of the *New York Times*, reports on the BBC World Service and various international news programmes.

We think it also changed the 'rules of the waves' as I shall explain in this paper.

Nautilus' two exploration titles are in Papua New Guinea's (PNG) Bismarck Sea and cover more than 5000 square kilometres of the Manus Basin, a tectonically active and well-mineralised geological province. Over the last decade, this province became a mecca for researchers who found it a 'living laboratory' of analogies to the volcanogenic massive sulphide deposits which have supplied much of the metal consumed by man over the millennia.

Many nations are expected to follow PNG's lead in developing a seafloor resources policy. Our message to any considering it is 'Please understand the Explorer's position'.

As we build our first "Terrestrial Mines in the Sea" many of our familiar terrestrial principles will apply. We have noted a tendency for people to regard the sea as an alien environment and to, therefore, imagine that the normal development principles of mining on land will not apply.

Mention 'mining in the ocean' and people are immediately at sea. Most seem to lose their bearings regarding the normal resource development sequence which runs exploration, resource identification, to reserve proving and finally to feasibility study. The first question I get asked is inevitably 'How is it to be mined?'.

I should say that while we are very impressed with the wide range of technologies and their evident ability to do our mining task, we do not have a 'Titan CX2000 Deep Sea Miner' (mythical) ready to go. Nonetheless, the first question ought to be 'How big is the resource?' and then once this is established, the how-to-mine question could be addressed during the course of mining and economic feasibility studies.

As our experience grows, we see more and more that the development methods and principles used on land will transplant directly to help create the world's first profitable 'deep water' marine mine.

## EMERGING ISSUES AND NEW POLICY

In the currently unfolding scenario, the overlap in the interests of marine mineral Explorers and international marine Researchers has set these two groups potentially on a collision course. As a result of Nautilus' plans for commercial mining, PNG has begun the first serious attempt to codify seafloor resources. While this policy is being drafted in PNG, and so it is timely for Nautilus to present our views on how Government, the explorer and the researchers can work together.

Mineral resources, whether on land or in the territorial waters, belong to the country, to the people. Governments frame laws that encourage companies to explore and develop mineral deposits in both places. Therefore our basic message here is "do what you would do on land".

The PNG Minister for Mineral Resources, Philemon Embil, announced in July 1998 that a special policy regarding seafloor resources is being developed by the PNG Government. Nautilus' consultation in the policy-forming process has required us to, carefully, think through our position, particularly as a new wave of international 'research' cruises prepares to head our way.

Nautilus' exploration licences are in PNG Territorial Waters and are instruments of the PNG Mining Act. We are told the draft seafloor resources policy may well be implemented as an entirely new *Seafloor Resources Act*, and perhaps as early as next year.

Today, I would like to outline the fundamentals that Nautilus, or any exploration company, wants to see satisfied, if we are to fulfill our vital role as a primary force in seafloor exploration and mining.

### **The linked roles of the explorer, the researcher and the government**

For successful minerals exploration and development, we see the most critical relationship as the one between the explorer and the host nation's government. In the brand-new business of marine mineral exploration and development, this *partnership* must be an especially workable one for the company and the nation to both get the profits they seek, particularly when it comes to jointly harvesting the benefits of marine research.

In about three years I think you'll see industry outspending research but, for the time being, research is where the big spending is and where most of the useful exploration data is generated. But first something about ships...

Unique logistical constraints apply at sea. In the terrestrial environment many parties can access an exploration area on foot, in vehicles and with aircraft. In relative terms these are low cost. Access is relatively free and does not carry massive cost penalties. But, at sea, a suitable exploration or research ship can cost at least US\$20,000 a day. If you throw in mobilisation costs and a couple of weeks work, there goes a half million dollar budget.

For the scientist on board, ships do two things; they transport them to the site and then act as the highly specialised work platform that is needed to do even very basic tasks like sampling rock. However, great value, great *economic* value, can come from the research cruise simply by having representatives of the explorer and the Government on board, and scientifically participating.

Having these guests on board, and participating, is at relatively little incremental cost and discomfort to the researcher. Also, research is meant to benefit the broader community and by having us on board it can. One of the primary justifications for the buckets of money Governments put into research, and for the access that researchers seek in foreign waters, is the economic benefit to industry and ultimately the community. In PNG, with Nautilus and the Papua New Guinea Department of Mineral Resources (PNGDMR) represented on board there is assurance to all that the economic value of the research efforts in our licence area will be captured along with the benefits of scientific research.

## THE IMPORTANCE OF RESEARCH

All discoveries of potentially economic 'deep sea' marine deposits so far have been the fruit of research. We are, therefore, in debt to the important business of the scientists who research the oceans and their floors.

Before the arrival of marine mineral explorers, researchers cooperated according to a rather complex and, to the industry observer, rather obscure set of protocols. These were driven by political factors such as international acts of friendship and the host nation's need to enhance its international profile through its acts of science. On a more basic plane, there was a need for them to match resources such as ships and cameras, and academic interests in common research topics.

In sequence, the Manus Basin has been visited by geophysical and geological parties from: Australia, the USA, Japan, Canada, the USSR, Germany and

France. I think on all but one cruise, an observer from PNG has joined each of the cruises. Explorers will see the observers' main job as the capture of scientific data in the national interest. And I am sure it also allays any general security concerns that go along with having a foreign ship working in one's territorial waters.

PNG ratified the 1982 United Nations Convention of the Law of the Sea (UNCLOS) on January 14, 1997. This means PNG's Territorial Waters, now include the 200 nautical mile 'Exclusive Economic Zone' (EEZ), and PNG now also has sovereign rights over the mineral resources in these waters protected under International Law.

Under the United Nations Convention of the Law of the Sea (UNCLOS), certain responsibilities attach to nations claiming the EEZ and maintaining their claim. With PNG having a strong national dependence on mineral production, it is likely that mineral exploration activities will play a significant role in it fulfilling the terms of its EEZ claim.

The Geological Survey must keep the key records for future explorers and to help assess mining proposals. Nautilus is learning very quickly in this virgin field. For example, even the basic principles of exploration present an ever-changing field of learning to us and we are conscious that we must share this learning with the Geological Survey of PNG and other sections of the PNG Department of Mineral Resources. As a result, in the future it will be able to serve us in the way we need it to and we hope it will also help PNG to better fulfill its national commitments.

### **The data chase...**

The UN guidelines in the UNCLOS stipulate that the originals of all data be deposited with the host Nation. But even if the host Nation could afford to store it all, what use would it be?

Nautilus soon noticed that the data, information and knowledge that research generates is voluminous - and not all relevant to exploration. Samples alone vary from tonnes of sulphides, buckets of mud, water samples, crates of deep sea clams, and hydrothermal fluid samples. Even biological samples can have direct value to the mineral developer seeking baseline data for environmental studies.

There are however, some complex matters to be resolved regarding data. Learning who needs what and where the data copies should most efficiently go will take time and collaboration.

## **Open or closed file?**

For the mineral explorer, the system of publicly accessible 'Open File' and confidential 'Closed File' material used by many departments of mineral resources, will need refining to cope with the status of research material. Currently, research material goes straight to Open File in the PNGDMR, although the scientific conclusions from it may only be published a year or two later. Nautilus believes this practice should be altered so that research information of potential commercial importance from within title areas is only released when the title is relinquished or when the title holder agrees that it should be released.

Nautilus is keen to see the term of marine exploration licences extended beyond the current two years, at least during the 'pioneering years'. Because of the need to develop and try the new exploration techniques, equipment and methodologies, it will initially take longer to explore than it does on land, although in the long run marine exploration ought to be faster.

Nautilus' technical relationship with the PNG Department of Mineral Resources will revolve around geological data, information, reports and samples - choosing it, storing it and working with it.

Conclusion: The relationship between the nation and the explorer is the primary and most critical one. The work of researchers should be transparent to each of them.

## **Guaranteed berths**

Representatives of exploration licence holders and the PNGDMR should continue to receive the offer berths on every research cruises which come to our licence areas. Nautilus is pleased that the 1998 SOPAC protocol for collaboration between licence holders and researchers is now at work.

Previously, the cruise plans of researchers wanting to work in PNG waters have been approved sometimes through diplomatic channels and by the PNGDMR. In the relatively low tempo environment of the past, this has worked well but in a more intensive future, Nautilus thinks the conditions regarding collaboration that apply to researchers and Industry would ideally be stated in regulations and law (in a way that does not discourage researchers or bury them in paperwork).

## **THE RIGHTS OF THE EXPLORER**

I think any future marine mineral explorer would agree with Nautilus' sentiment: 'We must continue to have access to data, information or conclusions gen-

erated from research work on deposits in our licence areas and access to all research cruises.'

Like commercial organisations, researchers covet their discoveries - and so they should. But should a researcher have priority when it comes to conducting research on his discovery? Recently, Nautilus was asked to comment on a situation where an independent research consortium wished to exploit another researcher's discovery without consultation.

Whatever the researcher's conventions might be in such matters, our response was basically technical and commercial: we could foresee problems if there was no continuity in activities, experience would go unused and new data might not mesh with what we, or another leaseholder, might have to the confusion of all. Perhaps a protocol or guideline that bestowed some privilege on the research discoverer might help to maintain an orderly flow of information.

### **A Win-win-win**

At Nautilus, we have tried to befriend and collaborate with researchers because we support what they do and have already benefited from them considerably. Moreso, we want to collaborate with researchers so that we can give them as much freedom to release information as possible. We recognise that scientific publications are the lifeblood of their businesses and that these mean the release of data.

However, we are also mindful that as explorers we must comply with the statutory obligations to 'report to and to ensure a well informed stock exchange'. Here, the implication is plain. Where researcher and explorer collaborate in a licence area, commercially sensitive information should only be released to the public domain with a sequence and timing determined primarily by the explorer.

The mutual rewards of Industry-Research collaboration are sure to grow. As funding flows in from Industry, more research will be affordable and paid for by industry. And more research will be required by the various political masters. Industry will benefit, as we have, from the keen minds in research and in turn Industry will lend its focused leads and its own discoveries to their curiosity. In our experience, it takes very little more than a face-to-face meeting and genuine exchange of ideas to ignite a collaborative effort. I expect a wave of exploration funding over the coming years will accelerate collaboration of this sort.

As I said earlier, at sea, on a shared vessel, it will be more important to cooperate with others than it has been in conventional terrestrial exploration and mining.



There will be a growing need for negotiated approaches and pooled results. Access to data and results can be a continuous process in a well-founded and well-intentioned collaborative effort between industry and research.

### **Researchers with 'other' commercial connections**

Inevitably researchers and explorers will have to find ways to work through commercial matters together such as protecting intellectual property and preventing conflicts of interest. Declaring interests and possible conflicts of interest will be most important to the building of good relations and will clear the way for more sophisticated arrangements.

Perhaps a good illustration of such a collaboration is our own case. After consolidating our lease position, Nautilus approached the Commonwealth Scientific and Research Organisation (CSIRO) with the offer of a 'research partnership' to support future exploration and mining. But the CSIRO already had a prior commitment to a consortium of companies to research in Nautilus' Manus Basin areas. Negotiations between all parties resolved the issues and allowed us to work side-by-side with different purposes. The caution exercised by the CSIRO first in declaring its position and then in arranging with Nautilus and the consortium so as to maintain confidentiality of information has made this double arrangement conflict-free.

The difference between a researcher *consulting to* and researcher *working for* a company comes down to the detail of the arrangement, and to whether that researcher has beneficial ownership in the commercial project. My main point here is that researchers cannot expect to work in this new environment of competing interests by simply announcing which hat they are wearing today.

### **Trespass**

In industry circles, trespass is not usually tolerated. Any situation where a competitor company tried to work on another company's exploration tenements without a formal agreement or joint venture would never be tolerated in a terrestrial environment. On land, no explorer allows another company to drop in on a drill rig and take away some of its core for assay. Its an issue that could boil down to straight trespass.

In exploring the licence areas it has, Nautilus will be learning lessons about their geology and also about seafloor exploration and mining, generally, that will benefit its future activities. One of the main purposes of the exploration licence is to keep the exploration lessons the explorer learns for its own benefit. Such knowledge has real commercial value.

## **Intellectual property**

We believe this, and will energetically defend this view if we see our intellectual property put at risk by parties who imagine that the same rules that apply on land do not apply at sea.

Even before the introduction of new policy or legislation, we believe sufficient precedent exists in the Law to uphold our stance on this matter. It is useful here to consider precedents such as the 1993 case involving Western Mining Corporation (WMC) versus Savage Resources in the Supreme Court of New South Warters NSW. WMC's alleged failure to observe the rights to data and information of the title holder, Savage Resources, led to WMC forfeiting its stake in the Ernest Henry copper-gold deposit, now a major mine, and to it facing adverse public opinion.

So when does 'research' become 'commercial'? It is a question that must be closely watched, particularly when the individual or institutional researcher or its employees also has other commercial interests.

Nautilus believes that researchers should have conditional access to carry on their important work in our licence areas. We believe each research cruise plan filed should carry with it full disclosure of such commercial interests. It should give undertakings that representatives of competing companies are not on board and that information will not be given to competing interests - without the title holder's approval. Where the research organisation also has commercial aspirations, it should declare these and state its full intentions for the work it proposes. The explorer needs to know it is not competing against researchers.

The cruise plan should be filed with the title holder for comment at the same time as with the Government.

## **Releasing research information**

Researchers need to be aware of the commercially-sensitive nature their results could have in a granted exploration licence area. We believe the title holder should have the final say on the publication of certain data and information about its tenements. For example, the CSIRO plans a shallow drilling expedition within our EL1196 for the purpose of testing deep-seated alteration patterns and mineralising fluid pathways, its aim, again, being to better understand mineralising processes (and the new PROD drill rig). There is also a proposal under consideration for deeper drilling under the Ocean Drilling Programme.

Clearly the release of drill core assays, which can be extremely commercially sensitive, will need our approval. On land, companies often need to exercise their discretion to defer the announcement of drilling results to give themselves time to generate supporting results that better qualify or quantify the initial results. But I am sure we will be keen to give it.

Why this must be so is more understandable if we consider the case of the public company (Nautilus is still a privately-owned company but is expected to list in the medium term). Stock Exchanges have very clear expectations regarding the timely release of information, and are among several regulatory bodies that are interested in directors seeing to it that information does not leak onto the market from other sources, thereby disadvantaging shareholders who are not 'in the know'. Ultimately, this ensures confidence and credibility in the financing of high risk exploration which will be put at risk, to everyone's advantage, if the system is compromised.

We hope that future seafloor resources policy creates the onus and the opportunity for such matters between researchers and title holders regarding release of information to be resolved.

But in any conflict, we believe that policies, laws and regulations should give the explorer priority in the economic and national interests. With the rapid advance of marine and mining technologies we think marine mines will have many more parallels with the terrestrial environment than people currently imagine. The matters of access and information will be no exception.

### **Environmental issues**

Understanding environmental issues in the marine mining medium is of paramount importance to both the PNG Government and to Nautilus. Already, cruises specifically dedicated to studying the marine life around the Vienna Woods, PACMANUS and DESMOS deposits have been conducted. The 1995 ManusFlux Cruise, collected biological data that will be valuable for mining feasibility studies. This and other biological information also has commercial value to mineral developers and should fall under the same access arrangements as mineral related data.

We hope that our efforts in preparing this paper and in seeking a clear operating environment serve to promote the best outcomes for all shareholders. We look forward to working with researchers and governments.

## Summary of presentation and discussions on Terrestrial Mines in the Sea

A world's first in marine minerals was discussed by *Mr. Julian Malnic*, CEO of Nautilus Minerals Corporation in Australia, in his presentation **Terrestrial Mines in the Sea; Industry, Research and Government**. The author began his presentation with a prediction that some time in the next few years it is going to be widely realized that there are hundreds of millions of tonnes of high grade sulphide deposits sitting on the ocean floor, on the surface, immediately available for mining; and that there will be a rush to claim this unclaimed frontier of deposits; and to establish legislation to do so; and that these will be the low-cost mines of the future, and will not only suck attention away from other marine activity but from mining for mineral resources in terrestrial environments.

In November 1997, Nautilus Minerals was granted exploration titles over the newly discovered, high grade, seabed, metal sulphide deposits at a depth of about 2000 m in the Manus Basin. The titles cover an area of over 5,000 km<sup>2</sup> within the archipelagic boundary which defines the territorial waters of Papua New Guinea. The deposits are actually a surface expression of more deep-seated hydrothermal activity related to diverging tectonic plates in the basin. Their proximity to the continental land masses has produced a suite of sulphide minerals of Cu, Zn, and Fe that carries with it anomalously high values of Au and Ag, unlike the mid-ocean sulphides in which the precious metals are generally sparse or absent. The minerals are found in individual chimneys, coalesced chimneys, or individual mounds forming on the sea floor at measurable rates and the economic evaluations that led to the granting of the exploration titles were based on surface sampling without regard to any minerals in the sub-seabeds. While the latest in exploration technology is being employed, selection or design of equipment for mining must await the results of more detailed characterization of the deposits and their environment.

There is no question that much of the technology advances that were presented here, and others that are being used by the deep sea oil and gas industry will be incorporated into the needs of hard rock minerals recovery. Another issue to which the speaker referred is the potential overlapping interests of marine mineral developers and scientific researchers. In this respect, the PNG Government announced in 1998 that a special policy regarding seabed resources is being developed. In the speaker's view the relationship between

the government and the commercial enterprise is the primary and most critical one in terms of confidentiality, and the work product of research organizations should be transparent to each of them.

He discussed some other issues in detail including the importance of research, the identification and selection of appropriate data, guaranteed berths, rights of explorers, trespass, intellectual property, and the release of research information, all important issues with regard to the management of marine minerals development, whether within or without national jurisdiction.

Extensive discussions took place following this presentation covering a variety of issues. Early questions centered on the nature of the resource including growth rates, age, comparative size, and grade of the deposits. Economic issues included evaluation of the deposits as well as exploration and mining costs; and technical questions referring to geophysical delineation, and positioning were discussed. References were made to ownership and environmental issues.

### **Growth rate of the deposits**

In response to questions the speaker indicated that there were various estimates for the growth rate of the smokers but thought it realistic that a million tonne deposit could form in 5 years. (See also the discussion of Dr. McFarlane's paper, Chapter 3,b. Ed.)

### **Comparative deposits and grades**

If the variation in metal content for every known sulphide deposit is recorded, one participant suggested, it would be possible to produce a curve of tonnage versus content for deposits all over the world. The deposit presented would fall in the uppermost part of the curve so there would be one million or so comparable deposits with these grades. The speaker thought that if the database was run with the understanding of where to look it would be a much higher frequency than that. An advantage of that data focused approach is that it is possible to determine the average grade immediately without having to drill hundreds of holes into the deposit. There are many known deposits for which it would not be appropriate to pursue further exploration, like the TAG deposit in the Mid-Atlantic because it does not have any commercial attraction. The participant agreed that there are economic possibilities for some deposits. Following this system it may be argued that there are giant deposits with more than 100 million tonnes formed in reducing conditions on land that have some characteristics of the deposits that are buried below the surface at Middle Valley in the Juan de Fuca Ridge. The speaker agreed that was a good comment as it illustrated there is a lot

of diversity and deposits were not just limited to those like the seamount off the end of Lihir. He thought, despite the diversity of deposits, it was not so difficult to see them and test them very rapidly with basic equipment because of their location under water. Even in a low-budget situation a lot can be accomplished with basic gear.

### **Age of deposits**

Asked about the age relationship of the deposits and what were the oldest deposits there, the speaker said, in terms of the gold deposits, it was too early to give a really meaningful answer.

The best estimates he had been given, because the sedimentation rate is 24 cm /1000 years, allows for quite a bit of back calculation about ages and he was inclined to believe that the whole event would be completed in 500 years. That correlates with volcanogenic massive sulfide (VMS) deposits on land, taking into account how many have stacked lenses of sulphides that probably reflect episodic bursts of hydrothermal activity.

Another interesting idea is that the heat convection could be sucking all the metals out of all the sediment paths surrounding the area and concentrating them at the crown of the heat plume. Now it is more commonly believed, however, that the deposits are formed directly from magmatic waters coming to the surface. Immediately below the surface there is evidence that the deposits we know as porphyry copper deposits start to form there and continue downwards. The underlying tectonic process, he said was a tensional environment and not a leaky transform or something like that as someone suggested.

### **Testing tonnage and grade**

Considering the variability of grade and volume on the bottom, the speaker was asked what ideas he had on the relationship of tonnage and grade and how to measure and evaluate them, because that was needed to make a feasibility study. The speaker was not sure if there had been any penetrative testing of the mounds and deferred to his Japanese colleagues who, he said, probably knew more about one of these deposits than anybody in the world. His colleague intimated that they had tried this but without success. Now they had a drilling machine but they did not feel that particular tool was good for detecting the vertical distribution of the hydrothermal deposition. They did not have enough data to estimate the particle distribution. The speaker thought that high resolution side scan would work to build a picture of the external shape of the deposits and the surrounding sea floor. From that it would be possible to estimate where the sea floor would be, lower the drill (PROD) on top of that surface, and drill 3 or 4 holes to 30 or 40 m before recovering the drill.

It may cost some thousands of dollars/meter but the advantage is that the drill enters sulphide and finishes as soon as it runs out of sulphide. When drilling on land it is not unusual to have to set back 500 m from the ore body and drill a 700 m hole to the contact before drilling through it. In that case the costs can be quite comparable.

It was suggested that the problem would be to make a good evaluation of the deposit because of the very irregular sampling grid that would evolve, whatever means was used. The estimation of the volume could be wrong depending on the number of cores from different parts of the deposit and so on. It would be very hard to make an evaluation of even the volume. Even if it is possible to image the external shape it is necessary to understand what is inside the deposit to calculate the real tonnage. That would require an appreciation of the true grade and distribution inside the orebody that would be hard to get. The speaker agreed that there may be situations like that but felt that because the extent of the deposit underwater can be seen, which is not normally possible on land, this was a decided advantage. In a terrestrial situation it is normal to drill on a grid and then to drill all the holes that missed first, and finally to estimate what is there. Then detailed definition work has to be done, again penetrating long distances of rock. So in comparison with land, it has to be high density work, but the grades are very forgiving. If all that is needed is a million tonnes as a threshold and 9 million tonnes can be seen, and in this particular case it may be more like 14 million tonnes, then maybe it is not so bad.

The speaker was asked if he had some ideas of the dimension or volume of the area having sufficient material to be considered as a unit? Replying in the affirmative he indicated, however, that because they may soon become a public company, that information was sensitive. Last February, he said, a paper was published in *Science*, that shows quite clearly the work that was done. It would give an idea how quickly the basic parameters could be established. Every industry has a group of consultants who specialize and you can see from the mining code that this is an area of intense interest. The code would need to be adapted to the proving of marine sulphide deposits as well.

### **Ore deposits and scientific research**

Some discussion had suggested that it was necessary to prepare professional evaluations from the point of view of a mining geologist and not a scientist. It was said that when the situation is the first of a kind, two stands can be taken. One can become very critical of the fact that it is not following a model and therefore there are major data gaps or one can look on the positive side and accept what data there are. It depends whether the purpose is to encourage this type of work or discourage it. It was suggested that what is needed here is to give guidance to the

Authority on how to address similar areas. A lot of what Nautilus had done, it was noted, had been on the back of marine scientific research in this particular area. The speaker agreed that they owed the discoveries in Papua New Guinea to Marine Scientific Research and acknowledge that. It was then suggested that there was a substantial hidden value in the exploration work completed by the scientists that would not likely be available in a similar situation on land and that had to be taken into account. This was an interesting and complex issue involving the expenditure of millions of dollars for international cooperation at the research level, profit making at the industry level, and social, environmental and management issues at the developing country ownership level. If the deposits sought are within the Area, however, these issues must be resolved directly by the International Seabed Authority. These are issues that would be sensitive also and would require considerable care in their resolution when the Authority was considering adaptations of the mining code.

### **Economics**

These deposits are stated to have a very low discovery cost, and a very short period for development. The speaker was asked if he had an idea of the development cost and could he make a comparison between the value of a tonne of sulphide ore for any given production from marine vessels with that of land-based production even though the metal content and the grade seems to be much higher on the sea floor? In response he stated it was much higher. In fact they had done detailed modeling in his company, which, regrettably, was a commercial matter that he could not discuss in detail. Generally the grade, even if the volume may be slightly wrong, is very forgiving because the costs are not huge. Just in crushing, grinding and materials handling there are generally savings to be made available by working on these kind of grades. A large ball mill or an autoclave leach vessel for one of these operations costs a large sum, and if the ship can be leased as expected, the capital expenses will be limited. On land, the mine up there on the mountain has to be paid for before the first dollar is earned. There tends to be a sort of new exploration cost that you know can go up suddenly and then, as suddenly, plummet right down to a very deep negative spike.

At the Lihir mine initial expenditures were a billion dollars and they immediately turned around to cut 300 million off the bottom of that. The money is only needed for a few months and then the net cash flow slowly turns around and climbs back up. The undersea mine is expected to have a much gentler dip and would respond more quickly to change without having to put that large amount of capital together. The company would have a certain scale of operability, he said, and these are the general indications for us at this stage.



Another participant indicated a possible concern in taking the cream off the top, or high grading in these early days, as had reportedly, been done to some of the diamond deposits, at the expense of the overall resource. The speaker indicated in response that in his experience the cut-off line in this type of deposit would be more crisp than in any other kind of operation he knew of so he had a contrary opinion. They would not be returning tailings and the cut-off line would always be exactly at the contact between the sulphides and the underlying rocks. He understood the concern and because this would be a first ever approach, in the nature of trial mining, it was not yet clear what they were going to discover and he would certainly pay attention to it.

### **Geophysical delineation**

It was asked how well the sulphide formation could be defined just by using acoustic profiling. In response the speaker indicated a potential problem that they described as a melted birthday cake with candles on top caused by chimney collapse. There could be a lot of this sort of record of the chimneys that could give the appearance of more volume than there is, if the chimneys are 20/30m high.

Regarding acoustic penetration of the sides of fallen chimneys and the sediment lying on the side, he said they had not yet paid attention to that and had not yet contemplated going below ground zero on the outside. They had not done any detailed sulphide penetration work below the seabed and had not really contemplated what might be down there. When that was done, he said, they might start to run into issues of disseminated ore underneath, occupying the fissures and the ridges and may well have to develop a cut-off. He agreed they would probably find some places where dead chimneys were lying underneath a cover of soft sediment and would have to learn how to recognize those too on the geophysical record.

### **Imagery and positioning**

Recounting an experience ten years previously on board the German R/V Sonne in the Pacific, a participant agreed there was a lot to learn from rapid methods like acoustic-, or photo-imagery. They had observed on one lowering what looked like a lot of asparagus about 10 or 12m high, separated by one-and-a-half diameters. They then lowered sample bottles for trace elements analysis of the water that had a distinctive smell. With the Sonne it was possible to take pictures of the area with chimneys and see by the color of the picture if it was active. They may have lost part of the deposit because the chimneys were very patchy in that area and perhaps in 20 years there would be a lot of chimneys. The field was at 4000 m depths so to take a sample would require 4 or 5 hours to go down, and another 4

hours to return which would be very expensive. To take the one described to be as big as the room where the workshop was taking place would be a complicated operation. The operation was in the Chilean Ridge area but the sea was very rough and it was very difficult to operate. There was no GPS and the site was found using very basic instrumentation. Now if such a deposit was found, at least there would be knowledge of exactly where it was located.

The speaker remarked that they, themselves, were fortunate in having an area that was in a territorial sea under quiet conditions, having high grade and a good potential for more; and they were working with a government that was encouraging the development of mineral resources. If they could break the ice there, he suggested, they could go to other places.



## Chapter 16

### METHANE HYDRATE RESEARCH AND DEVELOPMENT

*Dr. Michael J. Cruickshank  
MMTC Associates, Honolulu, USA*

**Methane Hydrates**

**Hydrate Research Programmes**

**Hydrate Stability Zone**

**The Economic and Environmental Effects**

**References**

**Summary**

## METHANE HYDRATES

Methane hydrates are solid, ice-like substances composed of water and natural gas (methane). They occur naturally in areas of the world where methane and water can combine at appropriate conditions of temperature and pressure. These conditions are found in arctic regions of permafrost, in deep water basins adjacent to continental shelves and in deep ocean basins where the sediment thickness is at least one kilometer. Their widespread occurrence in the world's oceans and seas, their ability to change phase from solid to gas when their natural state of equilibrium is disturbed, and other characteristics has resulted in the recognition of four distinct areas in which more information is urgently needed. These are their potential as an energy resource, their influence on seafloor stability when disturbed by activities such as drilling, their influence on global climate when massively disturbed by natural causes and the implications of indicated unique acoustic properties.

The immense volumes of gas, and the richness of selected deposits make methane hydrates a strong candidate for development as an energy resource. Recent studies by the U.S. Geological Survey have conservatively estimated deposits of this material worldwide to represent an untapped source of hydrocarbon energy twice the amount to be found in all known fossil fuels on earth. The *Oil and Gas Journal*, in 1998 quoted a range of estimates from 100,000 trillion cubic feet (TCF) to 270,000,000 TCF. The mean value (320,000 TCF) of the estimates of methane contained in U.S. hydrate resources would supply all U.S. energy needs at the present rate of consumption for 64,000 years.

Scientists and others urge caution, however, as the recoverability of gas from these deep marine structures is very problematic at this stage and while the published estimates of abundance are enormous, it is likely that most of the hydrate occurs in low concentrations and has no commercial potential. (<http://www.hydrate.org>)

Methane hydrate has been known in the oil industry for quite some time as a formidable nuisance in oil and gas pipelines, where, under appropriate conditions it clogs the lines much like cholesterol in the human arteries. As recently as the early 1960s respected opinion was that no significant amounts of hydrate could occur naturally and it had certainly not been recognized in the oceans. It was only shortly afterwards that hydrates were recognized in nature in the Siberian permafrost and in the late 1960s, the presence of oceanic hydrate was serendipitously identified on seismic records in the course of routine surveys; even today little quantitative information about them exists. In 1969, the U.S. Geological Survey assessed and mapped the global potential for deepwater petroleum. With the paucity of data available at that time the assessments were highly speculative and

no mention was made of gas hydrates. Projected occurrences were confined to shallow basins in the continental margins where a primary criterion for the presence of hydrocarbons was the presence of at least 1 km of unmetamorphosed marine sediments. Deep water targets of any sort were not then thought to be accessible commercially. In 1972, ARCO/EXXON first recovered a pressurized specimen of naturally occurring gas hydrate from a depth of about 650m in a Prudhoe Bay, Alaska exploration well. By 1996, 27 sites of gas hydrate sampling had been catalogued. In 1997 the first drilling campaign specifically designed for hydrate and related issues such as methane generation and flux was carried out by the international scientific Ocean Drilling Programme (ODP) on the Blake Plateau. This effort, which immensely increased the understanding of the deposits and recognition of their widespread occurrence on a global scale, has recently spurred more focused programmes.

### **HYDRATE RESEARCH PROGRAMMES**

The Government of Japan in 1995 was the first to establish a national exploratory hydrate research programme and in 1998 the Japan National Oil Corporation (JNOC) sponsored drilling tests of known hydrate deposits in the McKenzie Delta of Canada together with the Geological Survey of Canada, the U.S. Geological Survey (partly funded by the U.S. Department of Energy Federal Energy Technology Center, Morgantown, WV) and contracted the services of university and research institutes. The Japanese National Oil Corporation (JNOC) is conducting extensive research of a potential hydrate resource off Hokkaido Island and is on target to drill test wells in two locations in 1999. Commercial production is targeted for 2010, barely 10 years away. It is estimated that recovery of only one-tenth of the estimated reserve would provide Japan with methane for 100 years. The Japanese Government has authorized a second five-year plan, headed by NEDO (New Energy and Industrial Technology Development Organization, <http://www.nedo.go.jp>), which is intended to develop methane recovery engineering.

India, in 1996, was the second nation to establish a gas hydrate research programme. The Indian approach was somewhat different from that of Japan, which already possesses a large, high-technology industrial base and can call on large foreign currency reserves. The Oil Industry Development Board of India, as part of its plan to boost natural gas resources, earmarked \$56 million for a programme of methane hydrates research carried out largely under the auspices of the Gas Authority of India, Ltd. (GAIL). India is aiming at defining the national hydrate resource, and is encouraging industry to develop hydrate leases through advantageous tax structures and other economic incentives. Whereas the approach of Japan can be maintained in the face of low world energy prices, the present low energy price structure is retarding Indian activities.

Other nations are also conducting assessment of deep-water hydrocarbons, including hydrates. Canada, which closed its offshore minerals programme some years ago, is revitalizing its program. The European Union has allocated funds for development of methane sensors, specialized hydrate coring apparatus, and marine research to identify hydrate and quantify methane in European North Atlantic waters. In the United States, the first National U.S. Gas Hydrate Workshop in 1998 brought together government, industry, and academic research interests and proposed that research on hydrates should take place as a broad, integrated programme. At that time, industrial representatives noted that the major costs associated with development of the deep-water-drilling capability envisaged as a requirement for exploiting methane hydrate resources would not be available solely on the basis of a problematic hydrate target. Now, however, industry is exploring extensively for petroleum in the deep-water regions where hydrate deposits occur, and a drilling capability to the base of the potential economic hydrate zone of about 3.5-4 km, is already in place. More than 300 exploratory wells were planned for 1998 in depths of 1,000 to 2,000 m and greater, well within the depth range to explore for hydrate deposits.

The President's Committee of Advisors on Science and Technology (PCAST) recommended a major initiative by the Department of Energy, the U.S. Geological Survey, the Naval Research Laboratory and industry to evaluate the production potential of methane hydrates in U.S. coastal waters. In 1997, Senators Akaka (D.HI), Craig (R. ID) and Landrieu, (D. LA) introduced a bill to promote the research, identification, assessment, exploration, and development of methane hydrate resources and for other purposes. Senator Lott subsequently associated himself as a sponsor of the bill. The PCAST proposal was incorporated in the bill, now House and Senate Bills H.R. 1753 and S. 330, the Methane Hydrate Research and Development Act of 1999, with a planned budget over the next five years, (FY00 - FY04) of 5, 5, 11, 11, and 12 million dollars respectively. In carrying out the Act the Secretary of Energy would: (1) Facilitate and develop partnerships among government, industry, and academia to research, identify, assess and explore methane hydrate resources; (2) undertake programmes to develop basic information necessary for promoting long-term interest in methane hydrate resources as an energy source; (3) ensure that the data and information developed through the programme are accessible and widely disseminated as needed and appropriate; and promote cooperation among agencies that are developing technologies that may hold promise for methane hydrate resource development. A subsequent amendment included the National Science Foundation as a player and incorporated methane hydrates as a defined marine mineral resource within the Marine Mineral Resources Research Act (PL 104-325), giving research authority to the national Marine Mineral Research Centers to work with the hydrates programme. This inclusion was limited to research and did not have any implication for federal mineral policy or mineral leasing.

The potential reward of unlocking the methane hydrate energy bank includes centuries of energy independence, but, to date, an economic and safe method for sustained recovery of methane has not been established. The newly-discovered, low-grade oceanic hydrate and associated gas deposits are very large, but relatively low grade when compared with conventional hydrocarbon deposits. They differ in character from conventional hydrocarbon deposits in almost every respect except that they encompass significant concentrations of hydrocarbon. It is not immediately obvious how the methane will be recovered. It is not even certain whether hydrate or associated gas, or both, will be the preferred economic target; and definitive geologic models for the deposits have yet to be developed.

## **HYDRATE STABILITY ZONE**

The methane hydrates are found in low temperature low-pressure regimes of permafrost regions and high-pressure, moderate-temperature regimes in ocean sediments. Methane hydrate is stable in seafloors below about 450 meters water depth in open ocean with an average temperate hydrothermal profile that gives hydrate a wide pressure-temperature field of stability. Methane molecules are compressed closely together in the hydrate lattice. One cubic meter of hydrate yields about 160 cubic meters of methane at STP and about 0.87 cubic meters of water. The hydrate forms in a zone of thermodynamic equilibrium, the Hydrate Stability Zone (HSZ) that extends downward from the seafloor to some depth determined by increasing temperature. The base of the HSZ is a phase boundary. At constant geothermal gradients the thickness of the hydrate stability zone increases with increasing water depth and increased pressure. Where higher molecular weight thermogenic gases, such as ethane, butane, or propane occur, the hydrate stability field expands considerably. One percent propane in the gas mixture, for instance, can reduce the pressure at which the hydrate forms by nearly 40%.

There still needs to be workable geological models for oceanic hydrate deposits in order to develop appropriate recovery plans. Conventional hydrocarbon deposits can be compared with classical high grade mineral deposits in that high values are concentrated in relatively small volumes. Hydrates, as fundamentally low-grade deposits, will require secondary recovery techniques from inception of recovery. Developing dependable techniques to produce gas at specific rates in specific localities, will be the key to methane recovery. Like any large but dispersed resource, the locations of greatest concentrations of target areas favoring recovery must be identified. Research should be focused on identifying unequivocal physical property relationships from which hydrate percentages and mode of formation (cementation or pore fill, nodular or bedded, etc.) can be inferred. Advanced processing of geophysical information should then yield the same degree of certainty about target location that 3- and 4-D seismic processing for con-



ventional hydrocarbon deposits have attained. The developments that have taken place in industry in the acquisition and processing of seismic data, and the development of other techniques, principally electrical, have prepared a broad technological base on which to build. Because of this, the characterization of the deposits and determination of their economic value could be very rapid.

As for the recovery options, current knowledge indicates that forced dissociation of hydrate concentrations may produce, "a muddy soup of methane and water". This would create many problems within a conventional hydrocarbon recovery scenario. Other options for recovery of methane from the main economic target in the lower part of methane hydrate deposits have been proposed. These include drilling into the free gas layer to penetrate the deposits from the side and below to avoid disturbing the more unstable uppermost layers of the HSZ. In this scenario the removal of the underlying gas reduces the pressure on the formation, causing a continuous renewal of the gas by pressure-induced dissociation from near the base of the hydrate. This method would appear to be most suited to those deposits where widespread gas occurs in a closure below hydrate (Figure 1), such as in the Blake Plateau. The method is less likely to work where hydrate deposits are not underlain by substantial volumes of gas. Other methods for recovering methane from the oceanic methane flux are even less conventional. These include the capping of gas seeps emanating from more deeply-seated deposits, fracturing of the hydrates to produce a situation similar to that used in coal bed methane-type production, and controlled *in situ* oxidation for a local heat source. The actual mining of solid hydrate in the manner of an open pit is unlikely. It is more likely to consist of dissociating the hydrate and transporting the gas, after separation, because the problem of maintaining the gas hydrate as a transportable solid along with its very large volumes of sediment matrix would probably introduce intolerable environmental and logistical effects. Seafloor hydrates, however, could be pelletized *in situ* and transported to shallow water where they would slowly decompose to yield fuel and water. Alternatively, chemical additives may be used to make hydrate more stable at lower pressures and higher temperatures, which would facilitate its transport as a solid. Lecithin has been used for stabilizing hydrates when drilling through them in the Alaskan Arctic. It is likely that more intensive investigation will confirm that the hydrate deposits have a variety of naturally occurring characteristics and that many of these may be used to advantage in developing unconventional methods for the commercial recovery of methane. The wide range of options currently proposed for methane recovery from the oceanic hydrate system illustrates the present lack of a coherent strategy resulting from lack of adequate information.

In terms of seafloor stability, the presence of hydrates in the vicinity of petroleum operations has resulted in a number of potentially hazardous conditions.

Seafloor slopes of 5 degrees or less in the Atlantic continental margin should be stable but many slump scars are apparent. In these cases the scars are near the top of the hydrate zone and the seismic records indicate less hydrate in the sediment beneath them suggesting a link between hydrate instability and slumping on the continental margin. In the Gulf of Mexico numerous instances of slumping and gas emanations in the vicinity of drilling and pipeline operations have been recorded. Serious accidents involving the movement of previously stable platform legs, breakage of pipelines, and the sudden emission of massive quantities of gas resulting in platform fires and the loss of floating vessels have been reported. It has even been suggested, and not without some merit, that the sudden loss of vessels in the infamous Bermuda Triangle might be due to sudden hydrate gas release resulting from warm gyres spinning off from the Gulf Stream.

The presence of quick sands in drill holes associated with sudden gas release may be due to the remnant water from hydrate gas sublimation and adds one more serious problem to petroleum operations in the presence of hydrates. Such problems need to be accurately modeled and documented and techniques developed to avoid or mitigate them. Because forced dissociation of hydrate is primarily a matter of managing thermal regimes in the vicinity of exploration and production equipment, these problems almost certainly have relatively straight forward solutions. Long-term impacts of sea floor stability and safety owing to methane production, including the likelihood of subsidence, must be investigated so that safe, standardized procedures for hydrocarbon production and sea floor engineering can be assured. Hydrates also are becoming an important factor in offshore spills. In 1997, the majority of lease sales in the western and central Gulf of Mexico were tracts in excess of 800 m depth. In the event of well blowout or leakage at these depths, the fate of the released oil and gas contaminants will be affected by the transformation of the gas into solid hydrates. This will reduce the buoyancy of the spill plume and, ultimately, the transport and dispersion of the oil. A Deep Spills Task Force was organized by MMS in 1998 that included representatives from the major U.S. oil companies. This Task Force is funding a programme to develop robust models to predict the trajectories of deep ocean oil and gas spills under conditions that foster hydrate formation.

## **THE ECONOMIC AND ENVIRONMENTAL EFFECTS**

As with the energy issue, very little is known about the history of stability of gas hydrates, especially those dispersed along the sea floor, in a period of global climate change. Methane as a greenhouse gas has ten times the impact of carbon dioxide when released to the atmosphere but there is insufficient information to determine which geological processes might effect its release from the hydrates or to establish the fate of the gas in seawater. Methane release from the seabeds as a

result of sea level fall, or from the permafrost as a result of sea level rise would warm the global climate. This might counteract cooling trends to stabilize the climate, or it might exacerbate warming trends to create further destabilization. Either way, there are significant questions to be addressed.

Lastly, investigations by the USGS indicate that methane hydrates possess unique acoustic properties. The velocity of sound in hydrate is very high and significantly alters the properties of surface layers of hydrate-cemented sediments. Changes in specific acoustic characteristics have important implications for the use of sonar devices for defense, seismic exploration and research.

The importance of hydrates in the global human environment appears to be well demonstrated even on the basis of the minimal information acquired to date. The possibility of major economic and environmental effects resulting from natural causes or human disturbance indicates a significant need to focus on the unknown characteristics of this vast resource to enable it to be used to our benefit. In the U.S. the Methane Hydrate Research and Development Act of 1999 is a step in the right direction. In the ISA, it is an indication that hydrates should be under serious consideration in the formulation of rules and regulations for the Area.

## REFERENCES

Dillon, W., 1993, Gas (methane) hydrates - a new frontier: US Geological Survey, Public issues in energy and marine geology, March, 2 pp.

Max, M.D. and M.J. Cruickshank, 1999, Extraction of Methane from Oceanic Hydrate System deposits: Proceedings Offshore Technology Conference, Houston, May 1999, OTC 10727, 8 pp.

Schofield, T.R., A. Judzis, and M. Yousif, 1997, Stabilization of in Situ hydrates enhances drilling performance and rig safety: SPE Annual Technical Conference, San Antonio, TX, 5-6 October, pp 43-50.

[www.hydrates.org](http://www.hydrates.org), 1999, Natural Gas Supply Association web site.

## Summary of the presentation and discussions on Methane Hydrate research and development in the United States

Natural gas hydrates may be the most recent of the discoveries to make headlines and *Dr. Michael J. Cruickshank*, President, MMTA Associates, USA, presented a brief outline on **Methane Hydrate Research and Development** in the United States. A crystalline member of the oil and gas family, the hydrates are solid ice-like substances composed of water and gas, discovered in their natural state only about 30 years ago. One cubic centimeter of hydrate will yield about 160 cubic centimeters of gas and about 0.87 cc water at STP. They occur in areas of the world that are prospective for petroleum and where gas and water can combine under appropriate conditions of temperature and pressure. These conditions are found in Arctic regions of permafrost, in deep water basins adjacent to continental shelves, and in deep ocean basins where the sediment thickness is at least one kilometer. Their widespread occurrence in the world's oceans and seas, their propensity to change phase from solid to gas when disturbed, and other characteristics, has resulted in the recognition of four distinct areas in which more information is urgently needed. These are: their potential as an energy resource; their hazardous influence on seafloor stability when disturbed by activities such as drilling for oil and gas; their, potentially, serious influence on global climate; and the implications of indicated unique acoustical properties. The immense volumes of gas, and the richness of selected deposits make methane hydrates a strong candidate for development as an energy resource.

Recent studies by the United States Geological Survey have, conservatively, estimated deposits of this material worldwide to represent an untapped source of hydrocarbon energy twice the amount to be found in all known fossil fuels on earth. The mean value of the estimates of methane contained in U.S. hydrate resources alone (320,000 trillion cubic feet) would supply all U.S. energy needs at the present rate of consumption for 64,000 years. Scientists and others urge caution, however, as the recoverability of gas from deep marine structures is very problematic at this stage. While the published estimates of abundance are enormous, it is likely that most of the hydrate occurs in low concentrations and has no commercial potential. Nevertheless, the importance of natural hydrates in the global human environment appears to be well demonstrated.

The possibility of major economic and environmental effects resulting from natural causes or human disturbance indicates a significant need to focus on the unknown characteristics of this vast resource to enable it to be used to the benefit

of mankind. In the USA the Methane Hydrate Research and Development Act of 2000 authorized government expenditures of \$47 million over the next five years. India, Japan, and Canada have ongoing programs of R&D; for the ISA it is an indication that hydrates should now be under serious consideration when formulating rules and regulations for management in the Area.

Discussions centered on the validity of the resource estimates that had come from a number of sources and some questions were raised that related to their genesis and future discovery.

### **Validity of the resource estimates**

The suggestion was made that the very extensive resource numbers must have a limit, and perhaps they were a bit like taking the average global copper content of 5 ppm and multiplying by the total volume of the copper bearing rocks. It was implied that the projections were perhaps initiated in response to a need by the USGS to get money from Congress, which was understandable but would not be right. A lot of the resource would never be an economical asset. In response the speaker said it was a good point but he felt when the USGS put its name on numbers, they were generally pretty reliable. For a large part these may indeed be very low grade minerals, perhaps like the porphyry copper deposits which are very low grade but economic with grades as low as three-tenths of one percent. At one time these porphyry copper deposits were not considered to be commercial deposits if copper grades were below five percent. They have almost certainly put a limit on what is added to the resource base. A lot of other reputable institutions have presented estimates also and some of them are higher and some of them are lower, but even if only one percent of these hydrates were available it is still a very significant potential resource. Mr. Cruickshank went to note that there was a general agreement that resources of hydrates were vast although some researchers felt uncomfortable with such unexpectedly high numbers. Sometimes they are based on seismic records that can give pretty wide coverage in a short time, but already there have been a number of corroborative samples acquired, and the resource is widely recognized.

### **Age and distribution of the resource**

A few more remarks were made regarding the resources because, a participant suggested, the gas hydrates are a rather modern deposit that could have only been formed since the deep ocean had received the cold water produced in the north Atlantic. This would result in an unstable layer of gas hydrate that would have to be replenished because of the geothermally caused decay of the hydrate.

Hydrates can be found only in areas where it is still forming, this participant said. It was further stated that huge amounts of organic material are needed by the bacteria to form the methane and this process is balanced out by the geothermal decay of the hydrate, creating a very unstable situation. Once the organic material is used up the hydrate will disappear.

On the supposition that there might be unknown areas for hydrate formation, these areas can only be where there is a primary production high enough to produce sufficient organic material for the process. These areas are pretty rare and most areas shown in the Pacific are oceanic deserts with almost no production of organic material or any hydrate or clathrate deposits. The only areas of high production are the near coastal upwelling areas and the mid-ocean upwelling area and again they need the right physical conditions; low temperature and high pressure. The questioner would have liked to have seen a more elaborate picture of where to expect the hydrates. Dr. Cruickshank agreed that expectations in the mid oceans are not as high as they might be in near coastal areas but noted that there are areas of high primary production and hopefully some potential areas for methane discovery not yet targeted. Dr. Cruickshank further stated that the Pacific environment is different from the Atlantic; the bottom water is Antarctic and there is a very different thermal and sedimentary regime. Dr. Cruickshank pointed out that very little is known about hydrates, and that a lot of statements made about them are speculative. Even the Bottom Simulating Reflectors (BSRs) are not a reliable guide to the presence of hydrates as they are not even distinguishable in the Gulf of Mexico where many deposits are already proven by drilling. He pointed out also that even below the BSR there is not a solid layer and the hydrate may be disseminated, as seen from the ODP drilling and from other sampling and it is very difficult to assess the amount of hydrate in the sediments. He emphasised that there will surely be a lot of surprises as long as figures on the amount of hydrate worldwide are developed every time new ones are found. He observed that during the last four years three huge areas have been found with what is believed, in a conservative estimate, would be enough to provide the equivalent of over one year's global consumption of gas.

Another participant commented that he had just come from a cruise in an ocean basin where they had discovered a number of previously unknown volcanoes with gas hydrates: he had even held a clathrate in his hand. Now that we know what they look like, the participant observed, we will probably see them all over the place; we certainly know where to look anyway.



## Chapter 17

# NEW, PROVEN, MINING SYSTEMS FOR PLACER DEPOSITS ON THE CONTINENTAL SHELF

*Richard H.T. Garnett  
President, Valrik Enterprises Inc.*

**Abstract**

**Introduction**

**Marine Diamond Placers of Southern Africa**

**Marine Diamond Industry**

**Reasons for Commercial Success**

**Mining Systems**

**Risks and Rewards**

**Recognisable Trends**

**References and Notes**

**Summary**



## ABSTRACT

During the last decade the marine diamond mining industry of southern Africa has provided the context for the development of new placer mining systems for the continental shelf. These are now proven and constitute the foundation for an increasing annual production of diamonds, soon to exceed that from onshore sources.

The seabed deposits owe their existence to diamonds fluviially transported down the Orange River to the South Atlantic. On the coast they were moved, sorted and concentrated by high energy sea and wind conditions. Large scale, offshore production by De Beers Marine commenced in 1989 in Namibian waters. The company now acts as a contractor for Namdeb, a corporation owned jointly with the Namibian government. Half a dozen smaller, public companies also produce diamonds and conduct extensive exploration programmes.

Two important developments have occurred recently. Firstly, equipment for the recovery of diamonds from the seabed has been successfully borrowed from other industries. Large drills from onshore civil engineering have been modified for marine sampling and mining. Remotely controlled, seabed-mounted, excavational systems have assumed a major role. They allow both sampling and lining to be undertaken by similar or the same equipment, making the results compatible. Track- and skid-mounted designs permit highly selective extraction and enhanced recovery of the diamondiferous gravels from irregular bedrock in water as deep as 200 m.

Secondly, the total output of sea diamonds from Namibian waters is now around 0.7 Mct annually, and is increasing. Corporate and individual perseverance, government encouragement, new technology, shareholders' risk finance, and De Beers' diamond marketing have all played a role in the establishment of the industry. Future production is expected to increase as companies meet the challenge of working lower grade, higher volume deposits.

Grade and throughput rate, both founded on geological understanding, together with availability, are the most variable inputs in operational planning and production forecasting. The importance of reliable grade estimation is widely perceived, but the greatest performance risk involves the predicted mining rate and "digability" of the diamondiferous gravels.

Despite the wider choice of mining systems now available, none is universally applicable offshore. Some trial mining should be included in any feasibility

study. Published reserve statements should not only specify the proven mining method planned for use but should be internationally standardised.

## INTRODUCTION

Considerable advances have been made during the last decade in the exploitation of placer deposits on the continental shelf. In 1989, albeit in the very shallow water of Alaska's Bering Sea, the potential of a remotely-controlled, seabed-mining vehicle was clearly demonstrated for placer gold recovery. The gold price and other factors affecting the entire Alaskan operation prevented the machine's potential from being realised in North America [1,2,3,4]. Since then, however, similar and improved versions have been used in water as deep as 200 m for marine diamond mining in southern Africa with other systems, such as modified drilling and cutting machinery, the equipment and techniques are now proven for profitable placer operations on the continental shelf.

This paper, with the support of photographic material, provides a description of the systems, their manner of deployment, and the technical risks involved in the context of their application in the Southern Atlantic waters of Namibia and South Africa. The methods developed and the experience gained almost certainly have some application in other forms of marine mining in greater water depths.

## MARINE DIAMOND PLACERS OF SOUTHERN AFRICA

Between 1.5 and 3.0 billion carats of diamonds from the southern African hinterland are thought to have been carried down to the south Atlantic along the different historic courses of the Orange River (5). There they have been distributed by longshore currents under conditions of changing sea level over 1,400 km of coastline. Sorted and concentrated by the current, wind and wave energy', the diamonds exist in discontinuous economic deposits between points 450 km south and 300 km north of the Orange River, the boundary between South Africa and Namibia. Figure (1) shows the regional coastline along which the diamond-bearing gravels lie in drowned paleo beaches and other host features. They exist on the continental shelf to at least 200 m below today's msl, and from the shoreline to some tens of kilometers offshore. Because of changing sea levels some diamondiferous gravels constitute raised beaches along the coast and already have been extensively mined onshore.

Marine geological features of potential economic importance may cover less than 10 per cent of the seabed in a licence area. Location is more important than the areal extent of a concession. The diamonds have been sorted and sized by the transport process. They decline in size exponentially northwards along the coast and

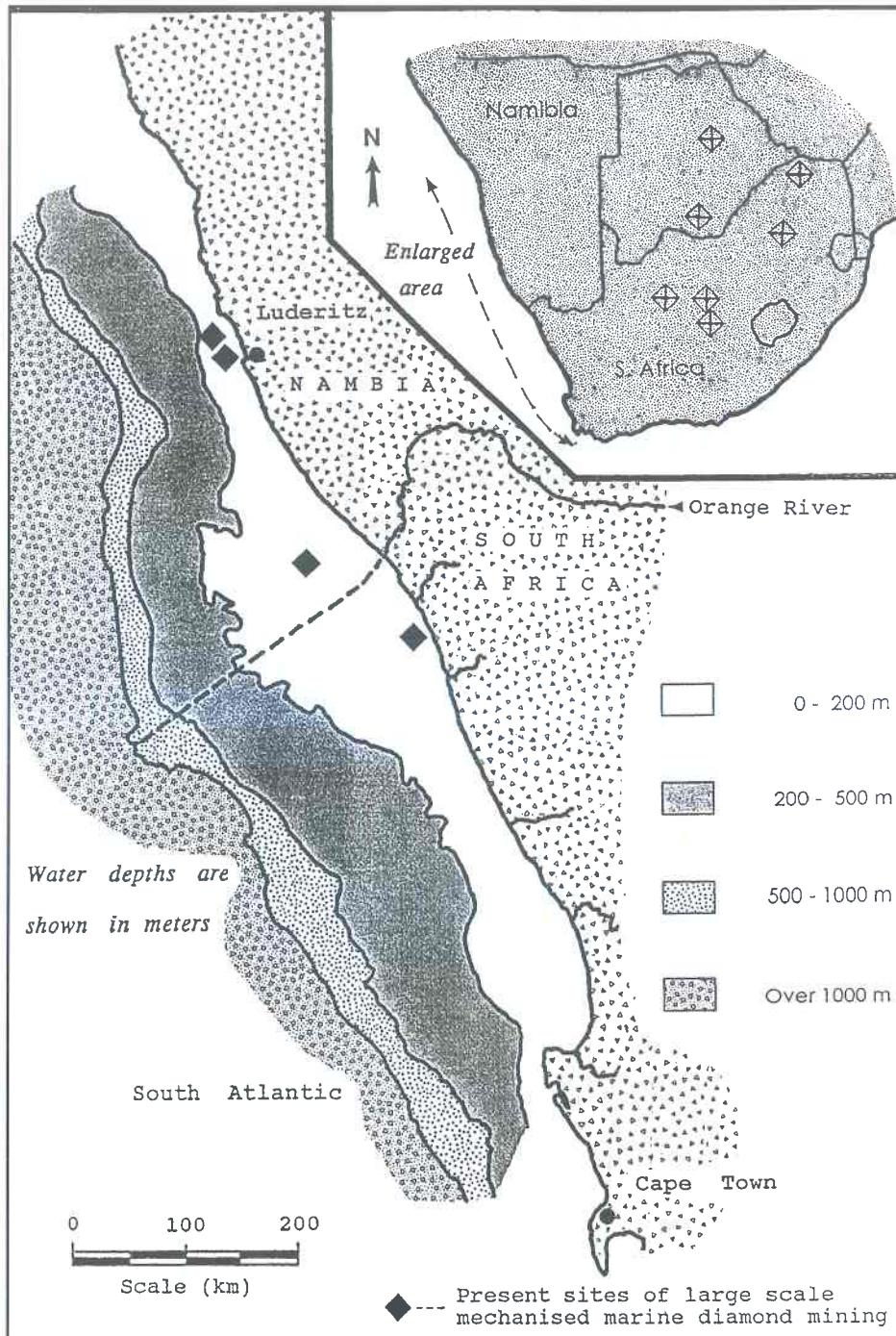

Figure 1

seawards from each ocean entry point of the paleo Orange River. Host diamonds tend to be concentrated close to, and on, the bedrock, and a typical grade profile is shown in Figure 2. Average sizes range from about 0.1 to 1.0 cts/stone, and in places more than one population may overlap. The gem quality percentage is high, generally exceeding 95 per cent.

Diamonds have collected in trap sites within favourable geological features: usually in gravels at the base of a sequence which is, in places, several meters thick. The gravel includes cobbles and boulders. Except for within the “mudbelt” at about 100 m water depth, the gravels are overlain by, and sometimes interspersed with, barren sediments comprising mud, sand, clay, and shells. “Beach rock”, a cemented sand which strongly resists penetration, occurs in places. The sequence is draped on a bedrock of gneissic or metamorphic rocks, and, in deeper water, sandstone and clay. The bedrock profile is complex. It may comprise gullies, potholes, inclined ridges, and overhangs, with boulders and slabs of rock. Vertical variations in the bedrock profile are of the same magnitude as the thickness of the sediment veneer. Favourable elevations, owing their origin to sea level stillstands, display higher grades and/or stone sizes.

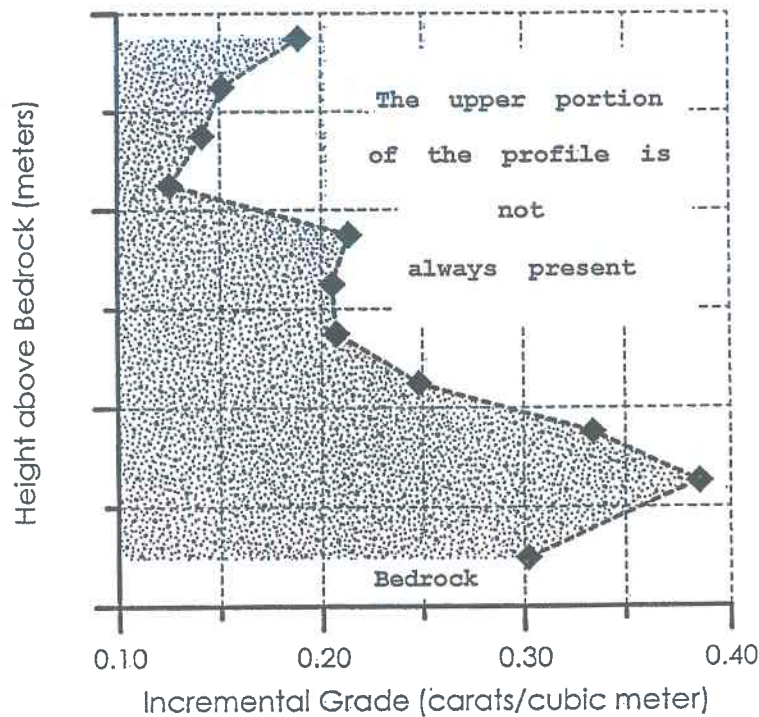

Figure 2

A full understanding of the seabed geology and of the complexities of diamond distribution is a pre-requisite to planning exploration and mining [6]. Comprehension is assisted by onshore exposures of deposits formed by the same marine agencies. The low grade of the marine deposits requires that large samples be taken for evaluation purposes. In one area a mass of about 60 t is needed in order to ensure a proper representation of the rough stone size distribution. The required sampling density is very variable. It depends on the features being evaluated, but may commence at around 1:50,000 for reconnaissance, closing to 1:1,000 or less for mine planning purposes. Sampling must distinguish between the total diamonds present, if measurable, and those recoverable. The latter varies significantly with the mining system selected. Overall, mining efficiency is judged by performance against sampling results, but paradoxically the reverse is also true.

It is ironic that the high and variable energy conditions that assisted in forming the southern African deposits also create a very inhospitable environment in which to work: high winds and extreme swells, with fog. The only harbours of consequence are Cape Town and Luderitz, with no other shelter available for very small vessels. All commercial mining activities are confined to the continental shelf. Regular diamond recovery is taking place at depths of about 120 to 150 m and as far as a few tens of km from shore. Sampling has extended down to 200 m and over 100 km. Geophysical surveying and ground truthing has now reached 400 m and more than 150 km from the coastline. In combination with the prevailing sea conditions, these depths and distances limit the applicability of different designs of sampling and mining systems. Marine mining equipment with rigid excavational arms, such as bucket-ladder, cutter-suction and bucket-wheel dredges [7], and considered to be conventional for tin dredging in the waters of South-East Asia, cannot be used. New marine mining systems have been developed and are now in constant productive use.

## MARINE DIAMOND INDUSTRY

Diamond production started on land following the 1908 discovery of a gemstone in the desert near the Namibian port of Luderitz. By the start of World War I 5 Mct had been mined from around the town. Large-scale, onshore mining by Consolidated Diamond Mines (DeBeers), in the same country, immediately north of the Orange River, became established during World War II. Production climbed relentlessly to 2 Mct/year in 1976. The resulting, continuous, onshore workings on the Namibian coast are over 100 km in length. In South Africa diamonds were found on land south of the Orange River in 1925 and by the mid-1950s onshore mining yielded 1.7 Mct/year. Historical, onshore production along the total coastline now exceeds 100 Mct [8,9]. The annual yield is now in decline as reserves are exhausted and is being overtaken by the increasing reward from offshore.

The marine industry's production is dominated by Namdeb Diamond Corporation (Pty.) Ltd., owned 50:50 since late 1994 by the Namibian Government and De Beers Centenary AG. De Beers Marine works as a contractor to Namdeb in Namibian waters, and acts independently elsewhere. Other significant producers are Ocean Diamond Mining Holdings Ltd. (ODM), Namibian Minerals Corporation (Namco), Benguela Concessions Ltd. (Benco), and Trans Hex Group Ltd. Diamond Fields International (DFI) is at an advanced stage of exploration and trial mining. Others are active in the early exploration stage and in small-scale contract mining. BHP Minerals was a joint venture partner of Benco and Diamond Fields in the mid-1990s.

ODM, Benco and Trans Hex have raised equity finance on the Johannesburg stock exchange. DFI, Namco and Trans Hex International Ltd. are quoted on the Toronto Stock Exchange. Namco is also quoted on Nasdaq and on the recently formed Namibian Stock Exchange. Marine mining is very rewarding financially to Namdeb and De Beers. Among the juniors, ODM and Namco have recently declared their first dividends.

Sea diamonds were first recovered from Namibian nearshore waters in the late 1950s, using relatively inefficient airlift equipment. Marine Diamond

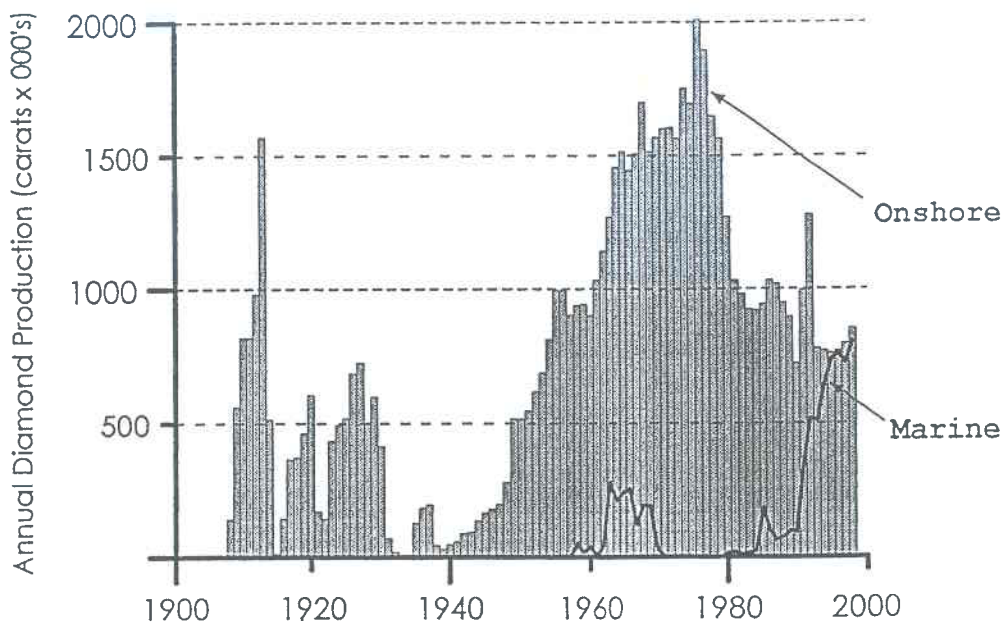

Figure 3

Corporation achieved a peak output of 0.25 Mct/year in the early 1960s. The company continued operating to the north and south of Luderitz until about 1970 when it was acquired by De Beers. Small scale, shallow water, production by various diving and airlift operators continued in both Namibia and South Africa. A spurt in output in the early 1980s could not be sustained because of inherent weaknesses in the mining systems then available and in the manner in which they were deployed at sea.

In 1989, before the incorporation of Namdeb, De Beers Marine commenced offshore production in Namibia, and Figure (3) shows the rate at which the total marine output has risen. A decade later the total yield by all companies in that country's waters is now around 0.7 Mct annually and is increasing. Although relatively small compared with a world supply of over 100 Mct., the high average carat value increases its contribution fourfold. Most importantly, the Namibian marine carat production now equals that from all land sources in the same country. South African marine production adds another 0.1 Mct and is poised to increase in the medium term.

### REASONS FOR COMMERCIAL SUCCESS

The present-day success has come fairly slowly to the industry, driven by several factors. Maintenance of a supply of suitably sized, gem quality, Namibian stones was a strong motive for De Beers. Offshore diamond grades are in places as high as those found onshore in the early part of this century. However, relatively high grades are needed because unit mining costs are at least twice those experienced onshore. A frequently-cited, cut-off grade for marine mining is around 0.1 ct/m<sup>2</sup>. Grades vary considerably but usually average around 0.25ct/ m<sup>2</sup>, with some features possessing around 1.0 ct/ m<sup>2</sup>.

Government encouragement has also played a part, with the recognition that a successful environmentally-responsible resource sector contributes to a country's economy. South Africa, both domestically and in pre-independent Namibia, then South West Africa, provided the legislative framework within which the industry could advance. Namibian grants and licence areas were defined at an early stage. The 12 primary South African concessions were extended to 20 in 1981 and were then sub-divided in 1983. Both countries have since extended boundaries out to the 500 m water depth.

For De Beers there was a lead time of two decades, the 1970s and 1980s, until the start of large-scale production. Exploration had to be undertaken but, equally importantly, the time-table was dictated by the rate of development of suitable technology. Continually improving geophysical surveying systems allowed the resolution of seabed and underlying bedrock topography details to be increased considerably. The advent of differential GPS permits a vessel to return to the exact site

from which diamonds have been recovered during exploration. Hydraulic engineering has increased the power available underwater. Fibre optics and developments in related sciences now allow underwater operations to be directed, monitored and corrected in real time. Observational ROVs are in common use, and De Beers Marine now employs a 2-man submarine for direct seabed observation of sampling and mining performance.

Perseverance, on both a corporate and an individual level, has played an important role. Management performance, through boards of directors, is ensured by responsibility to informed shareholders. The Central Selling Organisation has maintained relative stability in the rough diamond price, and all diamond producers benefit from De Beers' marketing. The greatest factor contributing to success in recent years, however, has been the development of more suitable sampling and mining systems for use offshore.

## **MINING SYSTEMS**

Water depths and the prevailing swell have prohibited the use of an excavation head fixed rigidly, via a ladder, to a floating pontoon, hull or vessel. A semi- or non-rigid connection is required. The first solution in the 1960s was the flexibly-mounted airlift which has since served as a work-horse for small operations. Better systems are now available, alone and in conjunction with airlift transport. Without any aggressive gravel collection mechanism, airlift system alone fails in places to achieve bedrock clean-up and full diamond recovery.

Experience has shown that major performance differences between even similar systems separately dedicated to either sampling or lining result in incompatibility of data. Sediments have been evaluated by airlift drills which either possessed different excavational characteristics or suffered from the same defects as the subsequent airlift mining system. There has always been a requirement for systems which could be used for both evaluation sampling and production mining.

The industry finally searched in fields other than mining for drilling technology which could be modified for offshore use. Both De Beers Marine and BHP Minerals found suitable equipment [10]. They selected the wirth drill and the Bauer cutter, respectively, systems which could combine aggressive excavation with vertical airlift transport. These mechanisms are suspended by wire rope or steel pipeline, with swell compensation of up to 9 m, through a vessel's moonpool. The wirth drill, with a maximum diameter of 7 m, has since become established as both a sampling and a mining tool. Each task can be undertaken with drills of the same design which, although not always of the same size, possess the same or very similar excavational performance characteristics.



But the most noteworthy development to benefit the marine diamond industry took place in Alaska. In 1989 WestGold, a Minorco Group company, successfully deployed an excavational machine on the shallow seabed for placer gold recovery. The "Tramrod", manufactured in England by Alluvial Mining, now Boskalis Westminster bv (Boskalis), was a 26 t track-mounted machine equipped with a centrifugally-assisted jet pump. The "Tramrod" lacked the integrated addition of a bucket-wheel to excavate cohesive sediments. Nevertheless, its four-month deployment demonstrated the advantages of such seabed equipment. The flexible placement of a seabed unit in a mining block allowed real time control, monitoring and correction. It also permitted a high degree of digging selectivity and opportunistic maximisation of resource recovery.

Late in 1989 De Beers Marine launched its track-mounted "crawler" which had also been developed from European technology. It was equipped with a bucket-wheel which was later removed, not being required for the more easily dug sediments in the Namibian grants. With other modifications it continues to be used from De Beers Marine's first large production vessel in areas of this sediment cover. Relevant details are as follows:

Mass:	50 t
Gravel collection:	Suction and horizontal attack
Gravel transport:	Airlift through twin 250 mm hoses
Deployment:	Launched amidships from a 77 m, 3,413 gross t vessel

Building on its in-house experience, Boskalis produced in the mid-1990s the "Namrod" for use by Namco. The machine is skid-mounted on the seabed and was designed for point and bulk sampling. It incorporates underwater screening of the sediments in conjunction with a range of excavational tools, and, although slow in operation, it was used successfully. Namco also commissioned the track-mounted "NamSSol" in early 1988. Very similar to the "Tramrod" in design the vehicle is over four times the mass. It has been employed very close to the boundary with DFI's Luderitz licence area for which locality its throughput was designed to be 1M m<sup>3</sup> /year of solids in sediments 5 m thick. In its first year of operation the "NamSSol" achieved a production of 240,000 carats, half of that reported in 1997 by the entire De Beers marine fleet.

Mass:	120 t
Dimensions:	8 m long by 6 m high by 5 m wide
Gravel collection:	Suction, aided by 20 t downward force and jetting water
Gravel transport:	Submersible centrifugal pump
Deployment:	Launched from the stern of 95 k long, 2,687 gross t vessel

Another remotely-controlled, seabed mining machine, the Subsea Diamond Miner, "SDM 50", is available from a group of European designers. Mounted on four skids, the walking unit has a design capacity of 1,000 m<sup>2</sup> /20 h day in sediments less than 4 m thick.

Mass: 75t  
 Dimensions: 22.4 m long by 6 m high by 9 m wide  
 Gravel collection: Suction, 400 m diam. Intake, penetration force of 75 kM, jet agitation, optional mechanical cutter and rock breaker  
 Gravel transport: Submersible dredge pump or airlift  
 Deployment: Launched from a stern-mounted A-frame

ODM is already using a similar unit, the Articulated Dredge Arm, or "ADA", for closely controlled sampling. Mining and sampling systems have become synonymous to achieve compatible results and efficient bedrock clean-up for optimized production forecasting and maximized resource recovery.

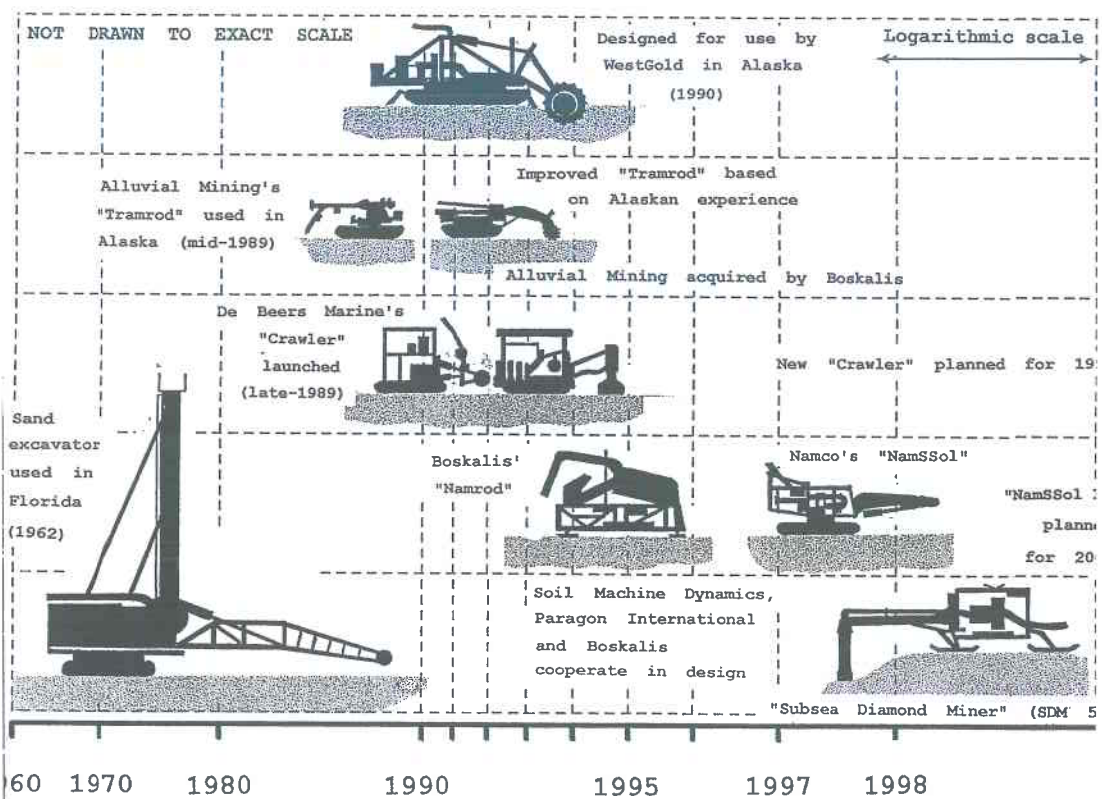

Figure 4

De Beers Marine now uses five production vessels, each equipped with either a "crawler" or a Wirth drill. A second generation "crawler" is soon to be brought into production on another addition to the fleet. The machine, reportedly, weighs 120 t and will mine the seabed gravels five to six times faster than the company's existing "crawler" and twice as rapidly as the larger Wirth drill. Three support vessels are available for exploration and investigatory work.

Namco and Benco presently deploy one vessel each. Following the success of its "NamSSol", Namco has advised that a second seabed machine, "NamSSol II", will be deployed in the year 2000. ODM has recently added a third vessel to its fleet, intending to increase its annual production from 60,000 to 100,000 ct. DFI has contracted out its confirmatory drilling and trial mining to one of the De Beers Marine vessels using a Wirth drill. All vessels engaged in mining are equipped with on board DMS plants for diamond recovery.

The progressive evolution of remotely-controlled seabed vehicles is illustrated by Figure (4), commencing with the manned sand excavator developed for beach rejuvenation in 1962 [11]. Such excavators constitute a major new stage in the development of mining systems for the continental shelf. Their use will doubtless increase in future.

## **RISKS AND REWARDS**

Marine placer mining is a combination of two industries: mining and, being weather dependent, farming. It is also the most difficult type of placer mining, involving the lowest mining concentration ever mined and being totally in deep water. Previous and present operators of marine gold and tin mining companies usually benefited from, but were sometimes constrained by, onshore experience. De Beers Marine and, to a lesser extent, Trans Hex, are alone in originally having possessed this advantage.

In general, the industry has many advantages, especially for the junior companies. It is relatively immune from any disturbing civil events onshore. Working sites can be changed easily, the metallurgical recovery process is relatively simple, and tailings disposal is not a major problem [12,13,14]. Capital expenditure is devoted to transportable vessels which retain a liquidation value. Most operating costs are directly applied to the mining operation, but the fixed costs represent a very high percentage of the total. Lead times have been considerable, but for new entrants into the industry they are now shorter if the correct equipment for the site is selected on entry.

Risk is always present and the early years were marked by loss of both lives and vessels. Excluding financing and marketing, the major performance risks are

now limited to four: recovered grade, mining rate, availability, and life of the reserves [15]. Industry is aware of the need to determine the grade through sufficient sample support and density. Given the financial resources, other shortcomings can be rectified with time, but not a major grade over-estimation [16,17]. Areas selected for mining may suffer from low geological or grade continuity. High selectivity of excavation becomes a major advantage to avoid lateral dilution. If the anticipated unit costs are exceeded because of low throughput, necessitating an increase in the cut-off-grade, then the reserves may become very fragmented. Any excessive splintering below the economically sustainable, smallest mining units (SMU's) seriously reduces the life of the reserves.

There is sometimes an insufficient appreciation of the greater risk created by the widely varying "digability" of the diamondiferous sediments. Shortfalls in production frequently result not only from grade discrepancies but also from significantly lower mining rates, depth penetration, and bedrock clean-up capabilities than originally estimated by the operators. Even for a proven technology the operation is not a matter of simply "vacuuming the seabed". The excavation capabilities of a system vary from one diamondiferous feature to another. There is no obvious system which is universally applicable. Due consideration has to be given to the locally variable geotechnical characteristics of an area. Incorrect choice of system may result in more than a 50 per cent shortfall in volume throughput and an even greater loss of diamond production capability. The learning curve in marine placer mining is steeper and longer than is generally recognized by newcomers to the industry. The achievement of maximum equipment availability is not immediate.

## **RECOGNISABLE TRENDS**

The advantages of a seabed-mounted, remotely-controlled mining system which can also be used for sampling are now clearly recognized. It is essentially a travelling platform carrying its own complete monitoring system and from which there may be deployed a variety of systems: for penetration, disaggregation, comminution, collection, screening, and transport. The portfolio of tools may be varied according to the localized requirements of each deposit, the characteristics of which invariably differ in subtle but important ways.

No generally agreed standards exist for the estimation and definition of resources and reserves specifically for the marine mining industry. In-house definitions are used by the operators, but acceptable international standards are required. Reserve statements, in addition to the other required disclosures, should state the tested and proven mining system. Test mining is an essential part of a feasibility study, and the award of reserve status should require a clear demonstration of the suitability and capability of the proposed mining equipment. In practice, trial mining

of a resource may progress to a full production scale before any formal reserve figure is announced.

Higher grade areas, presently, are being worked. In future, producers will maintain and increase their output levels only by further efficiency improvements and by mining lower grade ground. Higher throughputs, leading to lower unit costs, are possible by other mining methods, but at the expense of selectivity. For example, specially-designed, trailing-suction hopper dredges with the appropriate depth capabilities could excavate separately, both overburden and thick gravel sequences. Batch metallurgical treatment at sea could be conducted on floating platforms. Mining activities could also extend to the mudbelt, requiring new sampling techniques to access the underlying gravels and possibly modified metallurgical flowsheets.

There is little doubt that total marine diamond production of Namibia and South Africa will continue to increase, but all the ground of merit has now been licenced. Future output will come from the existing producers and those presently engaged in, or contemplating the commencement of, serious exploration. The junior companies possess individual strengths and weaknesses, and sole corporate rationalization of the industry already has commenced through merger and acquisition.

Elsewhere, exploration has been conducted along the coasts of Sierra Leone, Australia, Indonesia, and Angola, but, so far, without success. Either fluviially-transported diamonds did not reach the sea in sufficient quantities or the marine conditions lacked the high energy conducive to diamond concentration and upgrading.

## REFERENCES AND NOTES

- [1] Garnett R.H. T. 'Marine Placer Gold, with Particular Reference to Nome, Alaska', in Handbook of Marine Mineral Deposits, Cronan D.S. Ed., CRC Press LLC, Boca Raton, Florida, 1999 (in print).
- [2] Garnett, R.H.T., 'Marine Dredging for Gold, Offshore Alaska', paper OTC 8008 presented at the 1996 Offshore Technology Conference, Houston, Texas.
- [3] Garnett R.H.T. 'Problems with Dredging in Offshore Alaska', Mining Engineering, Vol. 49, No.3, pp. 27-33, March 1997
- [4] Garnett R.H.T., 'Development of an underwater mining vehicle for the offshore placer gold deposits of Alaska', in Alluvial Mining, Elsevier Science Publishers Ltd., England, p. 157-188,1991
- [5] De Decker R.H. & Woodborne M.W., 'Geological and technical aspects of marine diamond exploration in southern Africa', Offshore Technology Conference proceedings, Houston, Texas, paper OTC 8018, p. 561,1996.
- [6] Corbett I.B., 'A review of diamondiferous marine deposits of western southern Africa', Africa Geoscience Review, vol.3, no.2, p. 157,1996.
- [7] Garnett R.H.T 'The Availability of Mining Systems for Exploiting (Offshore) Deposits of Platinum and Chromium.' A position paper prepared for the Marine Minerals Technology Center Workshop Stockpile 2000', Hawaii, September 1991
- [8] Garnett R.H.T 'Recent Developments in Offshore Diamond Mining in Southern Africa.' Marine Technology Society Conference, MTS '92, Washington, D.C., October 1992.
- [9] Garnett R.H.T., 'Offshore Diamond Mining in Southern Africa'. 'Offshore Technology Conference' Houston, Texas, U.S.A., May, 1995, and. Mining Engineering, Vol. 47, No.8, pp. 738-744, August, 1995.
- [10] Garnett R.H.T. 'Marine Diamonds, with Particular Reference to Southern Africa', in Handbook of Marine Mineral Deposits, Cronan D.S. Ed., CRC Press LLC, Boca Raton, Florida, 1999 (in print).
- [11] Garnett R.H.T. 'Recent Developments in Marine Diamond Mining', Prospectors and Developers Association of Canada Proceedings March 1999.
- [12] Garnett R.H.T. and Ellis D.V., 'Tailings Disposal at a Marine Placer Mining Operation by WestGold, Alaska'. Marine Georesources & Geotechnology, Special Issue: Submarine Tailings Disposal, Volume 13, Numbers 1-2, pp. 41-57, January-June, 1995.
- [13] Ellis D.V. and Garnett R.H.T. 'Practical Mitigation of the Environmental Effect of Offshore Mining' 1 paper OTC 8023 presented at the 1996 Offshore Technology Conference, Houston, Texas.
- [14] Davidson Lo, Ellis D.V. Garnett R.H.T., et al. 'Marine Mining Technologies and Mitigation Techniques: A detailed analysis with respect to the lining of specific offshore mineral commodities'. C-CORE (Pub. No. 96-C15) contract report for U.S. Dept. of the Interior, Minerals

Management Service, OCS Report MMS 95-0003, edited by Woodworth-Lynas C. and Davis L., July 1996. 280 p.

- [15] Garnett R.H.T. 'Risks in Marine Diamond Mining -Lessons from the Past and Present'. Presentation to the 29<sup>th</sup> annual conference of the Underwater Mining Institute, Toronto, 21-24 October, 1998.
- [16] Garnett, R.H.T. 'Estimation of Marine Mineral Reserves', paper OTC 8020 presented at the 1996 Offshore Technology Conference, Houston, Texas. And: Society for Mining, Metallurgy, and Exploration, Transactions, Vol. 34, pp 69-82, 1998.
- [17] Garnett, R.H.T. 'Mineral Recovery Performance in Marine Mining', paper OTC 8009 presented at the 1996 Offshore Technology Conference, Houston, Texas. And: Society for Mining, Metallurgy and Exploration, Transactions, Vol. 34, pp. 55-63, 1998.

Note: Web sites for general information and more references:  
[www.diamondfields.com](http://www.diamondfields.com), [www.odm.co.za](http://www.odm.co.za), [www.benco.co.za](http://www.benco.co.za) and  
[www.interlog.com/-valrik](http://www.interlog.com/-valrik)  
A complete bibliography is available in references [1] and [10] above.

Copyright: Valrik Enterprises Inc.  
Richard H.T. Garnett,  
President, Valrik Enterprises Inc  
276, Beechfield Road,  
Oakville, Ontario, L6J 5H7, Canada.

Tel: (905)844-3389.  
Fax: (905)844-0784  
E-mail: [valrik@interlog.com](mailto:valrik@interlog.com)

## Summaries of presentations and discussions on “New and Proven Mining Systems for Placer Deposits on the Continental Shelf”, “Estimation of Marine Mineral Reserves” and “Mineral Recovery Performance in Marine Mining”

*Dr. Garnett described in detail, with many illustrations, the active offshore diamond industry in southern Africa. He spoke also on the subject of two more general, but equally important papers, Estimation of Marine Mineral Reserves, and Mineral Recovery Performance in Marine Mining. Both of these papers have been previously published and are referenced below.*

Giving a fresh look to recent advances in technology for seabed mining, *Dr. Richard H.T. Garnett*, President, Valrick Enterprises Inc, Canada, addressed the subject of **New and Proven Mining Systems for Placer Deposits on the Continental Shelf** and focused specifically on the marine diamond industry of southern Africa. *Dr. Garnett* stated that during the last decade, the industry had provided the context for the development of new placer mining systems for the continental shelf. These are now proven and constitute the foundation for an increasing annual production of gem quality diamonds, soon to exceed that from onshore sources. *Dr. Garnett* further stated that the deposits are derived from the Orange River alluvium and have been transported, sorted and concentrated along the coast by high-energy wind and sea conditions. Mining, he informed the workshop, initially began in 1964, but was discontinued because of high costs and inadequate technology. Production on a large scale by De Beers commenced in 1989 in Namibian waters and the company now acts as a contractor to Namdeb, a corporation owned jointly with the Namibian government. Other smaller public companies also produce diamonds and conduct extensive exploration programs.

*Dr. Garnett* noted that two important developments have occurred in recent years. Equipment from other industries had been successfully adapted for seabed diamond recovery. Large drills from onshore civil engineering works have been modified for marine sampling and mining, and remotely-controlled, bottom-sited seabed excavation systems have assumed a major role. Further sampling and mining could now be undertaken with the same equipment to give compatible results.

Track and skid mounted designs permit highly selective extraction and enhanced recovery of the diamondiferous gravel from irregular bedrock in waters as deep as 200 m. Grade and throughput rate are the most variable inputs in operational planning and production forecasting.



The importance of reliable grade estimation is widely perceived but the greatest performance risk involves the predicted mining rate, and “digability” (ease of digging) of the diamondiferous gravels. Despite the wider choice of mining systems now available, *Dr. Garnett* said, none is universally applicable offshore.

Trial mining should be a part of any feasibility study; and published reserves statements should not only specify the proven mining system to be used but should be presented in language according to accepted international standards.

*Dr. Garnett* spoke also on the **Estimation of Marine Mineral Reserves**, a complex but exceedingly important subject that is rarely understood outside of the minerals industry. Reserve estimation is a process that commences with sampling and culminates in the issuance of a reserves statement. The presentation was focused on granular, or placer mineral deposits, particularly tin, gold and diamonds that occur as marine placers on the continental shelf. *Dr. Garnett* observed that these types of deposits are generally low grade with erratic mineral distributions. Sampling, using a variety of special equipment, determines the extent and the grade of the mineralization. Sample size is important, especially for diamonds as the accuracy of the grade estimate is based on that and the sample density. Bulk sampling, or pilot mining, is a confirmatory process, which combined with the sampling data, dictates the choice of mining equipment, unit costs, cutoff grades and the selectivity of extraction. The size of the blocks to be mined and the reserves, are thus determined.

*Dr. Garnett* informed participants of a variety of estimating methods of differing reliability. He stated that the most sophisticated of these methods is Kriging. *Dr. Garnett* spoke of other factors that are required in reserve estimates in the marine diamond mining industry in South Africa. For example, he noted, dilution and losses during mining are taken into account in reserve estimation and a grade-volume curve is generally constructed. Unlike the metals, *Dr. Garnett* stated that diamond deposit estimation involves an extra variable, the dollar value of the individual stones based on their quality. During and after mining, essential feedback on the accuracy of the estimates are given by the R/E (Recovery/Expected Recovery) factor and by a mineral balance. Reserve estimates, he also noted, are required for several reasons and may be subject to public disclosure and audit. He concluded his presentation by stating that the use and understanding of the correct definitions is therefore, very important.

Following from his two previous discussions, *Dr. Garnett* presented a third paper on **Mineral Recovery Performance in Marine Mining** in which he discussed the effects of various factors, some of them outside of the operator’s control.

Recovery performance may be measured in absolute, or relative terms that relate the actual mining outcome to that predicted. The eventual mineral output is the only figure known with complete certainty. The paradox is that while performance is judged against the sampling, the reverse is also true. The choice of equipment for sampling and mining is very important. The sampling process may introduce errors and the wrong choice of sampling density may lead to poor mining block selection. The resulting recovery performance is best illustrated by regression curves. Changes in cutoff grade must also be taken into account to avoid unrealistic production targets. Estimation methods incorporating different mathematical assumptions and techniques may result in over- or under-estimation of the grade and volume. If the selective ability of the mining equipment does not match the size of the reserve blocks, the performance will be compromised. The treatment plant efficiency, the throughput rate, and the degree of cleanup of the bedrock also affect performance. The maximization of throughput does not necessarily yield optimum results and marine and weather conditions affect both downtime and performance. The speaker showed examples of the relative magnitude of different effects on performance, taken from actual operations.

There were no discussions following the presentations by Dr. Garnett but they had nevertheless been very well received, and the speaker was thanked for his formative and valuable inputs.





## Part IV

### Scope for Cooperation

<b>Introduction</b>		366
<b>Chapter 18</b>	<b>The Consortium Approach to Deep Seabed Mining</b> <i>Dr. Michael Cruickshank, MMTC Associates, Honolulu, Hawaii, USA</i>	367
<b>Chapter 19</b>	<b>Closing Remarks</b> <i>The Secretary General</i>	388
<b>Chapter 20</b>	<b>Conclusions and Recommendations</b>	392

## Introduction

It had been apparent for some years that there was considerable duplication of technical research among organizations developing qualifications and preparing applications for licenses within the Area and for status as Pioneer Investors under the rules on the International Seabed Authority. More recently, to that end, the efforts of these organizations, as well as the established Consortia, had changed focus and were being applied to the investigation of potential environmental impacts from mining on the deep seabeds and methods for their mitigation. These studies, generally applied to individual license areas, also tended to be duplicative or not transferable. Following the relaxation of the efforts of the original Consortia, and the consolidation of some of the U.S. licenses, a proposal was made to a number of other licensees to form a cooperative venture. They would make application to the ISA to mine one of the better prospective areas, then licensed under U.S. law, as an environmental demonstration. In this way, environmental effects and mitigating measures could be established under actual working conditions. New technology would be developed jointly by the participants and the costs of operations would be offset by the value of the metals produced, with the resulting net benefits, or costs, shared by all. The environmental information thus developed would serve as the basis for future planning and the development by the Authority of appropriate environmental and other rules and regulations required by law. The proposal was not consummated, nor was it rejected, and it was presented in this part of the workshop, among other things, as a basis for discussion among the participants and the Secretariat.

In developing the format of the workshop, the Secretariat had requested that the registered pioneer investors also include in their presentations some information on the scope that existed for cooperation, whether in the form of cooperation among themselves, or with independent research institutions and other kinds of researchers. This information was discussed during this part of the session and is reported here.

The workshop ended with closing remarks by the Secretary General that are reproduced here in full. They are followed by specific conclusions and recommendations developed from the workshop.

## Chapter 18

### THE CONSORTIUM APPROACH TO DEEP SEABED MINING

A discussion paper by

*Michael J. Cruickshank*

President, MMTC Associates

International cooperation in matters of commerce, defense and environmental security on a regional or global scale has become an acknowledged and attainable goal, and it is appropriate that such an approach to deep seabed minerals development be one of the items on the workshop agenda.

Currently the prime example of such cooperation has been the NATO military effort in Kosovo, and while hardly a happy or constructive effort, the power of cooperation of disparate national groups toward a common goal was certainly demonstrated. Imagine if the energy and capital expended had been directed to a United Nations effort to demonstrate the potential for sustainable development of deep seabed minerals. But these are idle thoughts.

In reality there have indeed been many cooperative efforts towards just such peaceable goals and there will be many others. The initial efforts to develop manganese nodules in the 1960s were based on five international consortia, involving 36 companies from 7 different countries, under the rationale that no one company could reasonably carry the enormous burden of risk to be undertaken.

More recently De Beers, in prospecting for diamonds off southern Africa, has gained access to a number of new areas through property acquisitions and joint venture agreements. The need for a broad scope of technology to address the environmental issues arising from coastal and offshore mining has resulted also in the need to involve operators in a wider range of organizations and facilities than previously. Minerals deposits have never restricted themselves to political boundaries and this problem is exacerbated in the containment of the effects of mining in the marine environment. Plumes of undesirable materials are not only carried across boundaries as airborne dust but may be carried in great quantity over great distances by the ever moving rivers of ocean currents.

Costly and revolutionary technology advances in the oil and gas industry as they head for deeper and deeper water has resulted in the unlikely partnering of erstwhile competitors.

Baker Hughes and Schlumberger formed an alliance to jointly develop an intelligent completion system that by remotely controlling activities deep within wells would eliminate the need for rigs to handle various downhole tasks, cutting operators' time and expenses. In 1997, Conoco struck a deal with Petroleum Geo Services to build a state-of-the-art floating vessel that would cost one-third of a conventional fixed or semisubmersible production platform and be built in half the time, allowing the economic development of a new field in the British North Sea. Apache Corporation, an independent producer, formed a partnership with Western Atlas' exploration and production division to explore 1,000 deep water blocks in the Gulf of Mexico. Western would be responsible for generating prospects and deciding where to drill; by aligning the interests of the two companies the operations will be more efficient and the return on investment of both companies enhanced. As operations for hydrates are planned the need for widely-varying expertise, particularly in some of the enviro-socio-economic aspects, will become very obvious.

Perhaps the best example of regional cooperative programmes which deal with the sustainable development of minerals in the oceans is that of the South Pacific Applied Geoscience Commission (SOPAC), involving some 18 countries in the Pacific. Initiated by the United Nations in 1972 as a-sub project of the ESCAP based Committee for Co-ordination of Joint Prospecting for Mineral Resources in Asian Offshore Areas (CCOP), the organization became independent some twenty years later. Highly effective in cooperation over a vast geographic area, the Commission has consistently been at the cutting edge of exploration and environmental technology for minerals development in the unique environment of the Pacific Island countries. New developments in gold-rich sulphide deposits in the western Pacific, and potential hydrate deposits throughout the deep ocean basins have enhanced the importance of this regional cooperative body as it moves into the next century. A major problem in low-lying Pacific Island countries, at this time however, is the protection and maintenance of beaches as populations increase and infrastructures are developed. Carbonate sand beaches, derived from the living reefs skirting the islands, have been, in many cases, the sole source of sand available for the construction of roads, hotels and other facilities. This has led to the catastrophic destruction of degraded beaches by subsequent storms and the loss of valuable lands and amenities. The need for a continuing supply of sand, made more critical in light of rising sea levels, is beyond the economic capacity of most of these small and isolated countries. The formation of a regional cooperative has been suggested, to acquire and stockpile sands from appropriate deposits offshore and deliver them, as needed, in the same way that oil and coal are delivered from a cen-

tral depot. This is the type of function that a cooperative body like SOPAC could conceivably manage with substantial regional benefits.

As for manganese nodules, the main focus of the workshop in Kingston, these resources still show a great potential for future minerals supply. Advances in technology are such that the known deposits seem to hover on the borderline of economic reserves, depending on the state of the markets at any time. The number of pioneer investors has increased to include China, Korea, and Japan as well as India. Each has to carry out detailed environmental studies in their selected areas. This duplication of effort is extremely costly and may also be limited to the minimum effort required to fulfill the mandate of the regulations.

A joint effort has been proposed to initiate a demonstration mining operation in one of the richer areas, and to use the operation as the model for intensive environmental studies which could then be applied, at least in the general case, to all sites. (Letter from Dr. Cruickshank to the Secretary-General in annex 1 and meeting announcement in Annex 2). Properly executed it is likely that the operation would be profitable and the environmental data and information would be acquired at essentially no cost. The ISA has expressed interest in doing this but the international agreements between operators may present some difficulties. In this, the economic downturn in Asia has not helped. The best areas in the Pacific are in the license areas of U.S. investors and have been offered as sites for such activity.



## Annex 1

(Letter dated August 15, 1996)

Dear Dr. Nandan,

Further to our brief conversation today, this document will outline the nature of my enquiry to you.

I have been working with OMCO consultants and others to develop a proposed environmental demonstration to be carried out in the Pioneer investment area of the CCZ and which would strongly influence the future efforts in deep seabed mining.

OMCO has informally offered to make available to an international consortium, at no cost, a significant part of their claim area in which to carry out a full scale mining demonstration which would result in a definitive understanding of the environmental effects of mining operations in the Clarion Clipperton Zone. The exceptional high unit value of the reserves in this area would allow a consortium to sustain a profitable commercial operation, even within the constraints implied by its dual use as a demonstration program.

I have spoken with representatives from China, CIS, Japan, Korea, and the U.S., and an exploratory meeting was held in Tsukuba, Japan, late last year, to discuss the idea. Response to the proposal was, for the most part, favorable but some initial questions arose with regard to the involvement of the United Nations through the International Seabed Authority.

These were, in general:

1. Would the ISA agree to a programmatic environmental impact assessment of the CCZ, based on this demonstration, being used for the license areas of the individual consortium members with the CCZ? This would significantly reduce the cost of duplicative, pre-mining environmental studies in each license area.
2. Would the ISA agree to provide an exclusive operating license to the consortium during the period of the demonstration? This would considerably reduce the economic risk for the operation which would be constrained significantly by the cost of the environmental monitoring aspects of the demonstration.

A copy of the initial announcement of the meeting which took place in November of last year is appended to this communication, for your information.

I would be very pleased to have your considered response to this idea and to the questions raised. I believe there would be considerable benefit in pursuing the proposal, in terms of the environmentally and economically sustainable development of these globally important resources, under the formal guidance of the ISA. Your advise on how to proceed with achieving these goals, to the mutual benefit of all parties, would be most welcome. Please let me know if you need any other information.

With kindest regards and Aloha,  
Sincerely,

Michael J. Cruickshank  
Director

cc:

USA Conrad G. Welling, for Ocean Minerals Company, Fax 415-322-1044  
Dr. Charles L. Morgan, MMTC

Japan Dr. T. Yamazaki, NIRE, Tskuba, Fax 81-298-58-8509  
Katsuhisa Ono, Overseas Activity Dept., MMAJ, Fax 81-33-503-3274

China Jin Jiancai, Secretary-General, COMRA, cc Liu Feng, International  
Coordinator, Fax 86-10-8533515

Korea Dr. J.K. Kang, Director, KORDI, Fax 82-345-418-8772  
Dr. Byung Ryong Moon, Director, R&D Policy & Coordination, Ministry of  
Science and Technology, Fax 82-345-500-3278

## Annex 2

### INTERNATIONAL ENVIROMENTAL OPPORTUNITY

(Copy of meeting announcement dated November 4, 1995)

Interest in the development of deep seabed minerals, including manganese nodules continues throughout the Pacific. The potential environmental effects of mining and their mitigation are still unresolved. International environmental standards for the conduct of mining operations acceptable to all parties are needed.

It is proposed to explore the possibility of forming an international consortium of Pioneer Investors to carry out a demonstration commercial mining operation to develop acceptable international standards for monitoring and mitigation of effects. Participation in this action would result in considerable savings, reduction in risk and enhanced environmental credibility.

The operation would commence as soon as technically feasible. It would continue until full capital payback was completed or for as long as mutually agreed by the consortium members. A period of 10 years might be appropriate.

The proposal is made on the premise that

- The operation would most likely take place in the Clarion Clipperton Fracture Zone in one of the established US License areas which would be of high commercial value.
- Each member of the International Consortium would contribute to the operation in a manner acceptable to all members, and distribution of receipts from the sale of the mined products would be pro-rated to the consortium members according to the value of the contributions made.

The environmental data acquired during the demonstration operations would be acceptable to the International Seabed Authority as the basis for a regional environmental impact document applicable with only slight modification, to the licence areas of each of the consortium members.

Technical and environmental data, information, and expertise would be freely exchanged between consortium members during the period of the demonstration.

On completion of operations the consortium would be disbanded and each consortium member would re-assess its interest in pursuing further operations. The unmined remainder of the licensed area utilized for the demonstration would revert to the original license.

Resolution of the following items is required prior to any formal decisions to proceed.

- Potential Participants (U.S.A., Japan, China, Korea, CIS)
- Location (US License area in CCZ)
- Environmental Targets
- Participation contribution and responsibilities
- Economics

Your immediate confirmation of interest is requested. If your response is affirmative, you or an appropriate colleague or member of your staff, are invited to attend a preliminary meeting to discuss the above issues. The meeting is tentatively scheduled for the morning of November 23, 1995 in Tsukuba, Japan, following the ISOPE Ocean Mining Symposium, to be held 21-22 November. The exact time and place is to be confirmed. Your presence at the meeting will not commit you to any further action.

Please confirm, or make further enquiries to me, by fax or telephone at the above address as soon as possible. I hope to see you there.

Aloha

Michael Cruickshank  
International Coordinator

Note: The meeting was attended by representatives of Japan, Korea, and USA. Travel problems prevented representation by China but communication was continued by mail.

## Summary and Discussions of the Consortium Approach to Deep Seabed Mining

Discussions on "The Consortium Approach to Deep Seabed Mining" were led by Dr. Michael Cruickshank who presented a short paper on the subject and followed by initiating discussion among the participants of the workshop.

In the mid 1960s development operations in the Clarion Clipperton zone were begun by five international consortia representing 36 companies from seven countries. Over \$600 million was spent in research and development with the objective of producing metals from manganese nodules on a commercial basis. No one company would have had the risk capital to invest in such a venture, but together each one was able to do so. Useful and valuable information is now available from some of the consortia that have withdrawn from the venture.

In frontier oil and gas areas in the U.S., companies will work with the government to drill exploratory wells to obtain regional information, shared by all participants, prior to the offering of designated blocks for sale by competitive bidding. More recently, oil companies have been forming joint cooperatives with service companies to explore and develop new, deep water fields.

In the discussions there appeared to be concensus that the consortium approach was a useful way to go. The presentations on nodule development indicated a considerable amount of repetition over the past thirty years and judging by the happenings in the oil industry it is indeed possible to work together, particularly in the early stages, and still be competitive. On the nodules it may be that most of the basic technical work has been already accomplished, but, in terms of environmental understanding, there are still many gaps in knowledge, particularly as most environmental issues are both place - and time-dependant and cannot be analyzed appropriately at any one point in time or location.

With regard to consortia among countries and other organizations with different legal and economic backgrounds and different levels of work already accomplished some of the major problems may have nothing to do with technology. Intellectual and real property rights, legislative constraints, assessed or imputed values of work done, all may serve to complicate the issues which may end up being driven by social, political, legal, and economic factors. Nevertheless, there are situations where cooperative activities are highly cost effective and willing partners can make it work.

Discussions were extensive and centered round the U.S. situation, databases, separate viewpoints on cooperation, project plans and other directions. Other matters involved the environmental viewpoint, metal prices and grades, the OMCO proposal, and a summary of the situation by the Secretary General including the functions of the Authority.

To initiate the discussions the speaker asked for a viewpoint on cooperative ventures of this nature? Korea has a lot of their proposed budget to spend still, Japan has already spent a lot, China appears to be in the middle of their efforts and perhaps it is a good time to re-assess the situation. Would it be good to partner on an effort like that and thereby save money, spread the risk and learn a lot? One of the participants said he was waiting to hear first some concrete opinions or attitudes from the international consortia. The speaker indicated that there were some situations where it was a little different than even a few weeks ago but he would respond with more specific details at a later time to any one interested. He had previously spoken with representatives from Korea, Japan, China, and the IOM.

### **The US situation**

It was suggested that everybody there was probably questioning what would happen with the large areas on the map of the CCZ that were reserved for the American consortia under license from the US Government. The speaker could not speak for the U.S. Government and did not know the answer to that question but he assumed that the license areas were not being adjudicated by the Authority at this time.

### **The data base**

Regarding the data from various US consortia that are on open file with the Center for Marine Resources and Environmental Technology (CMRET), formerly the Marine Minerals Technology Center in the U.S., the speaker said they were available for research use, after clearance by the originating companies. It would probably be useful to provide them to the ISA for their database and might be easily managed if the present licenses are de-activated. The data can be made available on request for the cost of reproduction. They include data and some samples from the Ocean Mining Association (OMA), Ocean Minerals Company (OMCO) and from the Kennecott Consortium (KCON). A limited selection of data on mining technology is also available.

### **A separate view**

An industrial participant with considerable experience in land-based mineral exploration offered some comments from another perspective. He was

interested in the profitable side of mineral development, he said, and did not see any kind of potential for manganese nodules. From his observations these few days as a newcomer it was obvious that there was a lot of repetition going on. Clearly if the Area had some purpose such as shared benefit for everybody, then it is not meaningful to talk about profits in the same way they apply in the EEZs.

The Area is a logical place for people to be working together and doing their politics in cooperation.

It seemed that if the amount of money already spent, and still being spent, had been spent cooperatively there could probably have been operations in production several times over by now, and there would have been some real answers to the questions still being asked about the economics and the environment. He felt there was a certain international responsibility among scientists and others working on this problem to get together and come up with some other form of progress in the Area; either that, he said, or conserve the earth's resources and give all the money to a poor nation or something.

The speaker indicated agreement with this comment, and that there was a lot of repetition. Everybody had experiences but they were spread apart; not that this fact totally negated them. Another participant commented that in the oil industry cooperation is in different phases; for example in an area that is going to be licensed, three or more companies would group together to do the seismic profiling and they would each get the same data. They would be able to print the data at the same time and then they would bid in competition for the same licenses. In another instance there could be another type of consortium for example for drilling development. This is an example of how the new deep-drilling technology has evolved. That happened also in the old manganese nodule consortia. These things can be seen from different aspects. Perhaps the way to get things going is not to have a consortium for everything, but to divide the work into specific problems that have to be solved and then work together on these.

Another participant asked if it would not be reasonable to take each section of the production process separately? The royalties or the spin off-technologies could be owned by whoever is working on them and if all interested parties joined together they could still have the spin off benefits. He thought IFREMER was a great example of a group that studied carefully and came up with a mature answer, that was to say "look it is not economic". Because they were a large organization they were able to re-deploy the people and capture the benefit of all of that work in other areas and continue to be the great organization that they are. It helped them to grow, so there are those sort of mechanisms that can be used. Teaming together was to him, he said, just an obvious thing to do.

One of the problems, the speaker indicated, was that some of the countries were way ahead of the others. For example, to join together on the environmental issues perhaps some had already spent all their money and some of them were just beginning, so who would be gaining in that? There was a potential problem there. It was pointed out that that would be the subject of discussion at the Council the following week. In the draft guidelines for the environmental impact studies it reads that the data should be made available freely. Some firms will not give it freely, they will want to charge but who can afford it? That is the question. So the formation of consortia is probably the best thing to do.

### **A project plan**

For a common project a plan would be needed first, suggested Professor Schwarz. For instance, would it be a technical development or would there be hidden technical and economic aspects, which would be quite different. For example, the project between IKS and DOD was running very well. That concept, could be extended, and adjusted. DOD supported the project with funds. DOD and IKS knew what they were doing; and the target is to show manganese nodule mining profitable after some time. The project is divided into two phases, Phase 1 is shallow water mining but all the problems have been included, for instance the catenary shaped hose, and the high pressure input. Phase 1 is to be completed at the end of 1999. Phase 2 would start in the year 2000 and would need a budget of approximately \$25 million. IKS believed that the money is available but if they could share the basis of the money it would be very helpful. Any organization, company, institute or country could join in the programme and all would participate in the results. He thought it was a very good idea, and he did not speak only for his own institution IKS. He knew that their Indian colleagues were thinking in the same way. He could not discuss more details that day, he said, but it was a time to start thinking about the possibility of joining into the research effort they were offering.

### **Another direction**

It was pointed out by another participant that this workshop was to review the state of technology. In some cases there had obviously been no progress for a long time, and in other cases people were still working. It was important to be positive and not take any of the pessimistic views that had been raised. There exists a Seabed Authority and it has to be doing something useful. Some of the problems have been recognized and some of the successes. As an output of this meeting it would be nice to list some of the bottlenecks, and some of the specific technical issues to which participants have referred; then to use a model perhaps to address some of these technical questions as a group. Later, the politics of actually doing it



would become a different issue. At least from a technical point of view we would have got a technical product.

### **And another**

Another participant thought it necessary to be realistic because, from the presentations during that week he had listed at least three different and very active projects, one with India and their German colleagues, one in Korea, and at least one in China. Maybe he said there were also some from our Russian or Polish colleagues who were not here to express their thoughts. However the others seemed to be completely dormant. The American Consortia seemed to be out of the picture. France had reached the conclusion that the nodules were not yet economic; there was probably no incentive to start again in the field of technology development and the best approach was to wait and see.

It may be difficult to bring people together from programmes that are dormant and programmes that are ready to continue, even though they would be the ones to try to do something cooperatively. To build an international programme on the development of technology that may be proprietary had seemed to him very difficult. The problems of the environment may be more open to shared activities, perhaps because there would be less proprietary concern, or the pioneer contractors would not be in the best position to make this kind of study. The understanding of the environment was still very much a scientific question. Potential operators would have the responsibility to make impact studies, prepare impact statements and subsequently control and monitor their license areas. Already they have assessed that what they will be doing would not cause significant damage to the deep ocean environment. To do that they certainly need the scientific community to provide better information on the dynamics of the deep seabeds, and the complicated interactions among the chemistry, physical geography, and biology of the bottom. In fact there is really little known at this time and we all need to understand more.

On that basis there may be some possibilities of building an international programme but it would be mainly scientific and the scientists would not be working cost free. They would need money and this money would have to come from the different governments. The problem is not restricted to the individual consortia, but would involve each country. He believed that the ISA should probably monitor, or at least, be the originator of the programme. Dr Cruickshank noted that as far as the environmental impact studies are concerned they would depend very much on the technology that would be used. The technology is now in its infancy so it would not be making progress to carry out some tests here and there that may

be considered in the future as not significant at all. The best that can be done to save money now would be to go to some large scientific study that would give a better understanding of the basic problems of the ocean bottom environment.

### **An environmental view**

Another viewpoint was presented by an environmental researcher. His organization had studied the environment for the last 10 years in the Japanese license area which had both a western side and an eastern side. The baseline data were quite different in these two areas he said, for example, in the western area, based on the latitude and primary production of the sea surface layer, the population of the benthic ecosystem were quite different, differing also with the passage of months and years. They had learned that sampling was not a good method to understand the dynamism of benthic ecosystems and they were developing new evaluation technologies for the benthic ecosystem. They now understood that 10 years was not sufficient time to understand that environment or to develop appropriate monitoring methods.

### **Prices and grades**

A participant remarked that if manganese nodules should take off they would have to have a higher content of metals than what had been indicated during the workshop. Not necessarily a better price, because even if the price increases, the competition with other sources of these metals may be the same, depending on the overall price of the combined metals. There is a need to know what is controlling the amount of nickel, cobalt and copper in the nodules and look for those areas that can have a higher metals content. Could they be developed more selectively, and would there be a larger variation in an area like the Clarion Clipperton Zone? These kinds of questions, he believed, were fundamental. Spending millions of dollars on equipment to bring them up should not be the first priority. It should be to find better nodules. Use the money to find better nodules, delineate the deposits, and get a better understanding of the variation of metal content; start in that direction and the technology could be developed afterwards.

Another participant said he would tend to totally agree with that view because if metal prices rise, mining companies, especially those in production already, would add the incremental cost of bringing in another 25-50% production from the existing mine, and you are back to square one. In his own work with placer minerals, he noted, the grade always guided him and he felt the grade here was too low. He thought it needed more work to see if there were higher grade zones that could be mined by more selective methods. That seemed to him to be the only hope, he said.

Another said there would be no chance. The grade was rather constant so there would be lower grades. In the central area of the CCZ where he had been working there were some blank areas that have probably had the highest grade that had been found in the world ocean. There may be a variability in the abundance on the bottom, but that would be apparent only at the last moment when delineating the area to be mined. Well that would be another way of saying higher grade of course because that would be dollars per sq. meter. The speaker pointed out that there are definitely variations in dollars per sq. meter in those areas because the values reported by Ocean Minerals Company (OMCO) were very high compared to some of the other locations. In the Cook Islands EEZ there are also variations with very high grades although these are cobalt deposits as opposed to nickel in the CCZ. There are certainly variations throughout the seabeds. Asked why there was cobalt in the Cook Islands and nickel in the Clarion the speaker said he was not sure.

### **The OMCO proposal**

Participants from China commented on the original U.S. proposal for cooperation. They had studied the suggestion very carefully, they said, and they knew the quality, abundance, grade and topography in that area were very good. The conclusion, however, could not be positive.

The reasons indicated were first that the legal situation of these areas was quite different because the licenses was issued by the U.S. Government and, second, that the investment required was very large; they had had discussions with other experts in China and could not find an appropriate solution because the company wanted to change the data and technology if China wished to cooperate with other consortia. Third, was the possibility that if COMRA or China wished to apply for a second area then, as a developing country, they may legally qualify to apply for some reserved areas held by the Authority. These were various reasons which were presented to OMCO. This is an international forum and if they worked together with other countries or companies they believed the proposal would be a positive one. After they had studied the suggestion, they had given that conclusion to the company and they wondered if the situation for the license had been extended perhaps for several more years.

Dr Cruickshank thanked them for the discussion but stated that he did not know the answer to the last question. It was remarked that if the US Government had extended the licenses of the different American consortia that would mean that it continued to block the area.

## Comments of the Secretary General

Recalling the purposes of the workshop, information made available in similar fora and the papers and presentations made at this workshop, the Secretary General of the International Seabed Authority addressed a number of the issues that had been raised during the discussions. The text of his comments are reproduced verbatim below:

“We have had a very interesting survey of developments in technology for deep seabed mining during the past few days. The last workshop convened by the Authority related to the environment and during that workshop a comprehensive survey of the research that is and has taken place was provided. On each occasion I have been struck by the fact that various entities seemed to be undertaking the same activities in different places. You will see that in the proceedings from the last workshop that we earlier circulated.

The methodology used by each entity was relatively the same and to a large extent the results obtained were the same, except for variations due, in most cases, to the different locations, the different equipment used and the different objectives of the schemes that were undertaken. What was common was that the same study had been done in different places, each organization spent their own funds and basically repeated what the others had done.

Here we see that, with respect to technology, we had the very first set of pioneers including the U.S.-led consortia, Japan, and France and now, the registered Pioneer investors who are now very much engaged. Each one is doing the same thing over and over again, trying to design and develop technologies, test them, and discovering the same problems. Each has been trying to find its way to something that would be satisfactory and yet nobody has perfected anything. In the process much knowledge has been gained but what we are not doing is building upon the knowledge gained by one and developing it further to the next stage and the next stage and so on.

Everyone is going for a certain level in technology development and some have got there and stopped going further; yet the others are repeating the same thing and I suppose they will also come to the same level.

What you see is that there has been an expansion of funds and effort but each one is trying to reinvent the wheel. It is as though everyone is trying to develop a car but that they all want to start from the model T, and are not picking up where the last one stopped and moving forward, as they do in their own countries. There are people who begin from scratch to manufacture cars but they build upon the experience in manufacturing cars that has been gained elsewhere.

Unfortunately, of course; there is an element of nationalism in this; it is the history of how people always started with each one going their own way. That is why so much money is spent. The consortia that are awarded licenses plead commercial secrecy, they do not want to share their technology with anyone else. Even governments sometimes do not provide information, although they are obliged to. And there are those who feel if they do provide information, it is covered by an official secrets act and all kind of things happen. I find that the best occasions we have had in this whole process, and I have been involved in it for some time, is when we get you all together in a meeting like this where there is an exchange; people exchanging experiences, information, data, commenting and observing; of course not everything comes out, but a lot of open discussion does take place. As I sit and listen I say to myself what a great pity when there is a shortage of funds that so much effort and funds are being expended and I wish there was some way of getting together to build upon the knowledge that already exists and move forward.

I know that in international relations it is not easy to do that since everyone is operating from different bases; some are government operations, some are state supported, some are private; of course there are no consortia here except the US one; and incidentally we do not recognize their rights to anything; because the very basis for any claim is negated by the fact that in the consortia there are a number of companies involved from different countries. All except the United States have become a party to the Convention and by not doing so, the US is prohibited from undertaking activities or allowing any claims by anybody outside the Convention regime. It is a question of when the others will denounce the agreement with the US and the US will decide not to proceed with this unilateral legislation. I think the US recognizes that, they have admitted so in their submission to the senate; so the issue of legality is very clear I think; it is the Convention that prevails.

I do not think the site is an issue if cooperation is in mind because we can always take a site from the reserved area. If people want to work together to undertake an environmental study or whether they want to do more than that in terms of technology development I do not think the site is an issue because you can test anywhere. So I do feel it is a great pity that there is this duplication of effort and there is no way to help people to get together and work together.

I recognize that some have gone ahead and some are beyond others in terms of development or technology or tests that they have done *in situ* therefore why should they wait for others and give their knowledge and experience to others?

There are of course different schemes already underway in different places, as in India or China or Korea. So it is difficult, but if some way could be found where people can collaborate, by sharing cost, reducing the cost to each of you, it will certainly be to the benefit of all.

As I said at the beginning I do not see seabed mining, at least with respect to nodules and other areas, as something that should be considered as an exclusive right. It is really like outer space, it is a new frontier where you have to collaborate and get to the point where you can harness or be capable of harnessing those resources before you think in terms of competition. I know that at one time there was competition for sites as I think you explained yesterday; that there was overlapping and so forth and I do remember the situation that existed and how everyone was sort of clamouring to get a site but I think we have gone beyond that phase; at least most of those who were aspiring for sites have got them and its really something that we are at that stage where it is very much an experimental situation.

Now I take up a point on which Mr. Lenoble spoke, that is possible cooperation in marine science. When I talked to the scientists it was they themselves who thought after listening to each other that they were duplicating their efforts and they thought that the ISA should develop a model for scientific research in which they could all participate because they are using government funds and they are just going ahead and designing things to do and if they could participate in something which was a model and global in nature and contribute to that process it will serve their purpose as much as it will serve the global purpose. In fact they requested us to do so and I think if I am not mistaken in the book you have, there is some mention of a possible model for marine scientific research especially with respect to the environment; so there is desire on that issue and we hope that at some point in time, with the help of the scientists and eventually the Legal and Technical commission, we will develop such a model to encourage such cooperation.

One of the functions of the Authority is to play a catalytic role with respect to marine science, to promote marine scientific research, to disseminate information, to promote marine technology, and to promote the study of the marine environment. It is not just related to nodules or to any other kind of resource but it is a general mandate and we should look at that and indeed I hope that we can move in that direction as far as marine science is concerned. Coming back to the issue of cooperation I think it is good that we exchanged views on that here and we should go back and think about it, see whether there are possible ways. Of course we could be the catalyst but it doesn't have to be that way. It could be cooperation among various states or various operators and the private sector or other institutes that want to cooperate. Certainly one thing that comes out very clearly is that I don't think any organization can develop technology for seabed mining on its own given the cost involved and the fact that there is no incentive to do so except as research.

One might say the same thing about outer space. There was no profit to be made from outer space but people still went there and they are now operating there commercially. Basically it was research and of course since then we have developed

the satellite communication aspect, but at that point I don't think the effort was envisaged in those terms. It was a new frontier when President Kennedy declared that the US must put a man on the moon within the next decade. It is the same thing I think with respect to marine science and marine research. One can't always think in terms of profit though private companies do have to think in those terms. I doubt that in the governments that have invested so much already, the operations were necessarily thought of in terms of profit as much as in terms of research and development of marine technology and marine science; so there has been a sort of fusion of this as far as the government supported operations are concerned.

To summarize, I think that the discussions are very useful and worthwhile to continue. Perhaps at some point we can see whether there are possibilities of cooperation, either individually, collectively or otherwise.

One other point was raised, I think by Mr. Simpson that we should be discussing the problem areas, or as you said, bottlenecks in the development of technology. I was so much hoping that that would be the kind of discussion we would have but I think it was important for this meeting at least to do a survey of what has happened, what is happening now and what is projected for the future. I think it would be useful, if people want to exchange views on problem areas, that we have another meeting of this kind where we could look at concrete problems, having done the survey already of the developments of technology. You have all been very supportive and I think all of us can think very deeply about this situation. There may be a way and certainly I will think about it myself and keep in contact with you."

### **A Korean viewpoint**

A participant from Korea indicated that personally it was very good for him to participate in these discussions on the international level and in this workshop. In his opinion there were several subjects and methods of approach to deep seabed nodule mining. Making profits from deep seabed mining was the first reason and the background of the application of Korea to be a registered pioneer investor; however the environmental impact assessments were also very important.

As he had said the previous day, he recalled, Korea was a latecomer in this field and wanted to be a good partner in international cooperation too. Therefore its activities must be harmonized with the international philosophy and concepts for deep seabed mining. However, Korea belonged to that group of countries that needed raw materials and paid billions of dollars every year for importing these resources. Therefore, the Government of Korea wanted to be ready for commercial mining from the pioneer area, either alone or through cooperation with other pioneer investors, or through international consortia.

However, he noted, all the processes would need to be complete. For example, within an international agreement, the other countries would have to agree with Korea's strategy; but this wait and see strategy that has been described, frankly speaking, he stated, depressed the enthusiasm of Korea that was driving the first stage.

This participant questioned whether they would need cooperation with partners having advanced technologies or having experience and data on effluent discharge from pilot mining tests; for common commercial mining or to import only the technology? They had expected also that the development of technology would be very good and that there would be spin off from the R&D activities; but if it is necessary to wait such a long time then they could not expect spin off from deep seabed mining technologies anymore. On the other hand they would have to import all the core technologies from the other industrial sectors.

If environmental impact was so important and they felt it was, then they would have to have an environmentally-friendly mining technology as introduced by COMRA the previous day, but in order to get such environmentally-acceptable mining technology Korea would have to invest money for R&D activities too. This wait and see strategy, he continued, would not promote the required national consensus for investment in their technology development. Therefore, he sought a clear and positive attitude from the International Consortia or from the Seabed Authority with regard to the promotion of commercial mining from the deep-seabed rather than prohibiting it or breaking it off. The development of technology itself, and the preservation of the environment in an appropriate manner were very important, he thought.

Dr Cruickshank noted that the suggestions contained a very useful approach and it was useful to have the views of Korea because they are important. On his part, he said he was not as pessimistic as others had been. There are different economies and they don't all depend on profit. Some of the central economies have a different approach in terms of expenditure for R&D and hopefully there may be some way to encourage the development of environmentally-appropriate technology for these operations.

### **A metal rush**

A quick comment was made by a participant who said that people should ask themselves what would happen in the event that some of the projections are correct about the future of sulphides. That there would be a 15 million tonne deposit discovered off Tokyo and more potential elsewhere. There would be a few in the west Pacific and on the other side of Japan. Then hundreds of millions of



tonnes of high grade sulphide deposits that could supply copper. The attention would go to sulphides. It would go more to the EEZs, away from the Area and partnerships would form along the lines of the partnership that Australia has with Papua New Guinea. There would be an expectation for people who see alternative supply as an important thing to establish or to justify scientific research, that there would be a new realm of forces. Where would all of this stand in the event that that happened? He believed that it would happen within a few years. It was seen to happen when the manganese nodule thing started in the first place, he noted.

It was, he further noted, all of that competition that chewed up that originally nice shape into the little bits and pieces on the maps that had been shown during the workshop. That was the result of a stampede that happened back then and he just offered that as a catalyst for thought. Dr Cruickshank acknowledged it was food for thought but re-affirmed that there were still optimists among the participants as well.

### **Marine scientific research**

Concerning marine science, a participant pointed out the importance of the Authority's policy for the scientific researcher who may hesitate among different areas. He noted that there is competition in science and for the moment the new trend was global change, or research that involved important socio-economic issues. For example, in Europe they had just begun their fifth framework programme for research and development and it was now established for the next 4 years. There was nothing about marine minerals in that programme, but he believed it was very important to point out the importance of marine scientific research in that field. Certainly the economics may not be there for the time being but very little is known about the deep sea environment, and he believed it was important to promote it at a very high international level.

Another participant agreed and stated that he had been very impressed by the grades of the polymetallic sulphides on the seabed, a sample of which had been passed around. He stated, further, that as a result of activities in the marine diamond industry, the governments of Namibia and South Africa had financed basic research through universities, not to make a profit, but to benefit the country and its population as a whole and they have made the results freely available to the various mining companies. The two countries had provided a framework for those mining companies to start mining and now there was an industry that had been using self-propelled crawlers on the seabed for 10 years. That was a lot of good experience although the operations had not been as deep as the nodules.

He noted that De Beers had never actually formed a joint venture but had formed a fifty-fifty equity relationship with the Government of Namibia to form a company called Namdeb. Within this framework De Beers Marine acted as a contractor to Namdeb but the government had allowed it to get established before inviting its cooperation. If interest continues in polymetallic sulphides what would happen of course would be that those companies that had 10 years of experience operating self-propelled crawlers and other types of equipment in diamond mining would be going to go to those small governments in the Pacific and saying “hey lets get together, you have the resource and we have the experience and the technical knowledge” and so he would see that as the next stage. This he concluded was a logical development, especially for those companies engaged in diamonds that also had also had experience in mining polymetallic sulphides on land.

Dr. Cruickshank said that would be a very favourable thing to happen. He had always stuck with the idea that there are no two mineral deposits alike; there are high grade deposits and low grade deposits and you could not really say the sulphides, just like that, or the nodules, or the crusts – were “the sole deposits” of interest at any given time.

He noted that there would be areas where there would be exceptional deposits. He was very optimistic that there would be occasions along the way where new mines would be started. He could tell no more than anyone else if the rush would be as great as it was in the old days of the gold rush; or the more recent diamond rush, but it could happen and certainly this idea that there would be a possibility of government cooperation is a very good one. Even in Hawaii the Federal Government had funded an environmental impact statement for cobalt crusts that cost about four and a half million dollars and all that money had gone to universities. Publicly-funded research results are public information and many companies had used those documents now; it was certainly a good way to go.

Another participant claimed that the example just used had been in actual fact a description of what had happened in the Pacific. The South Pacific Applied Geoscience Commission (SOPAC) had started for that reason, that there were so many interests involved. They did not always work together but they tried to; and that had been a reason he believed, for the International Seabed Authority, to bring people together in this workshop. So he had felt it was the task of every one there to try to help the Authority whose best intention was to do the best for the rest of the world; not for those present perhaps but for the following generations.

There was no further discussion, but the Secretary General ended the workshop with some closing remarks presented in Chapter 19.

## Chapter 19

### CLOSING REMARKS OF THE SECRETARY GENERAL

This was a very interesting workshop and I must say that as a layman I was certainly able to familiarize myself with some of the things that are going on with respect to the development of marine technology, but I think, more importantly, this was an occasion to allow you to exchange views and to review the technology development efforts that have been made over the years. I hope that has been as beneficial to you as it is for the Authority. As I said when we began this meeting we hope to publish the proceedings and I hope my colleagues will find a way of capturing all the aspects of the workshop particularly in light of the fact that so much was in the form of films and other visual aids, and of course a lot of discussion took place on an impromptu basis. I don't know whether there is full record of that. If any of you feel that you could better make your point by giving us what you said here in writing in improved or more detailed form we would appreciate that. It will be also included in the proceedings so we look to your cooperation in that regard as well.

It has been very interesting to see that efforts are being made to develop a safe technology for nodule mining and we had a very interesting presentation on diamond mining. I think that technology in some ways is perhaps more sophisticated than some of the rudimentary stages that the technology for nodule mining has reached and will be useful for other purposes. Also, we heard something about the polymetallic sulphides, the smokers that Mr. Malnic's corporation is working with. That was very useful too because we heard so much and saw the headlines in the papers which made it all very curious. We had a very good presentation and update on ROVs and the prospect for their better development.

I had thought as just an observer that the early systems for nodule mining were being developed by the consortia, based on two premises; that it had a large capacity and that it was reliable. What we see unfolding, however is the evolution of seabed mining systems in which environmental considerations have become a significant new element in the design and development of the technology. Clearly, it appears that seabed mining technology for nodules has reached a certain stage at which it seems to be on hold, particularly in the cases of France and Japan.

I don't view that as necessarily being a negative approach with regard to the comments of Mr. Hong, our colleague from Korea. Don't take it to heart. It should be seen as a challenge to reach at least that stage. I think in each case the basic issue is one of funding and everyone knows there are times when something has been going on over the long term, there is a problem to sustain the financial, political and other support for the project. I think this is probably the case for both France and certainly Japan, which has gone through financial problems in Asia. I hope that one day they will revive and move forward from where they are. So these developments are not necessarily negative because after so much effort and work it stands to reason that if they have successfully tested some equipment it would be only natural that at a certain point in time they might move forward beyond that stage.

On the other hand, we have seen that the three newcomers in the field are aspiring to develop technology and are working on their own, each one probably doing the same thing, but, nevertheless, each one is making effort and there is a commitment to achieving certain goals. So the impression that one often gets is that there is nothing happening when, in fact, there is, maybe at a very slow pace, but people are making great efforts. In addition to technology development a considerable amount of site survey is taking place, I know that China went twice this year to their site. I am sure the others are all active in one way or another so there is activity in seabed mining. The discussions gave a very useful review of the evolution of technology for seabed mining, in particular with respect to nodules. Having covered the historical aspects, I believe we should have another workshop at an appropriate time to review what further has taken place and what rightly should take place. I am not saying next year but perhaps two years, three years later. By that time we might hear from our polymetallic sulphide friends how they are faring and how far they have gone ahead. I hope the sulphides are not too hot to handle then hopefully we can get some samples. Diamond samples as well. I am very impressed that you are mining, or about to mine, at depths as much as 400 m.

It is very useful to have a series of workshops on different aspects of seabed activities and the next one we are projecting would deal with polymetallic sulphides, crusts, hydrates and other minerals. We hope to hold that workshop next year sometime, but it will much depend on the schedule of meetings for next year and would be decided when the Authority meets next week.

If you know of experts who have been studying or researching these areas that I mentioned I would very much appreciate if you gave their names to Mr. Odunton so that we could at least invite a few people who can make some presentations like we have done this time, so that we can have a useful meeting on all the other forms of marine minerals.

For your information, while the Convention addressed manganese nodules and laid out quite a lot of rules for their development, they left it to the Authority to develop rules with respect to other types of marine minerals, as the need arose. Under the terms of the Implementation Agreement, Part 1, any state may make a request for the development of a mining code or mining regulations for any other minerals from the seabed. The Authority is then obliged to develop those regulations within 3 years of such request. Last year Russia made that request so we are now beginning to look at the possibility of developing appropriate regulations. The workshop next year would be very useful for that process because we have to see what would be adaptable from the present rules and regulations for nodules, to sulphides and crusts and other minerals; or how different the regulations would be, given the nature of the resources concerned; so we are proceeding in that direction.

I know some of you have talked about metal sulphides and I think some of the indications are that there is greater interest in that today than in the nodules, but in any case we are obliged to proceed with regulations and will indeed do so.

Other areas on which we would like to have workshops in the future, or have input from the scientific and engineering communities, include development of common standards for data collection, and standards for values attributed to the data collected, or the information that is developed. In this way we can avoid the problems of diversified approaches, bring about uniformity, and assist the scientific community in standardizing data collection and evaluation of the data.

Regarding the scientific model I spoke of, we will explore the possibility of proceeding with that as soon as we can. I think it is a good idea and something that is positive and immediate. It does not involve us in the same way as the development of seabed mining but it does help the Authority to play the catalytic role it ought to play, particularly in the promotion of marine scientific research. I would like to raise these matters later on next week with the members of the Legal and Technical Commission, and ask their advice on the direction we should be moving. I am myself very occupied at the moment in trying to give the Authority a more technical orientation, which it ought to have.

We have been in the realm of diplomacy and law making and that is important and of course we need those diplomats and lawyers if for no other reason than to get our budget approved. I am not saying they are redundant, they are very important because the governments have to be behind our efforts. I think the time has come, however, to give equal opportunity to the scientific and engineering community for their inputs. I think the Authority should be more and more oriented towards technical and scientific matters and I would like all of you to think of the Authority in that way. It is my hope that the Authority will develop to a point

where it can be the best repository in the world for data and information on marine matters as they relate to the area of international seabeds. In that regard we are trying to develop our database and I know there are considerable quantities of data and information available in different institutes, and different government databases as well as in the industrial community. There are people who have expressed their willingness to make these materials available to us. Our problem at the moment is to develop the capacity within the Authority to be able to accept them and make them available to others for study and exchange in a timely manner. Of course we can also classify as confidential materials that we should not disclose to others without the permission of the donors. In developing our collection we may also look to some of the member states to help us. We have started in a small way but I think we still have a long way to go.

Finally let me say how very grateful the Authority is to you all for giving up so much of your time to come here. I know that we did not give you much time to go to the beaches and enjoy Jamaica but I think you have been most helpful to us and I am very, very grateful at the seriousness with which you devoted yourself to this workshop. I appreciate the amount of work that must have gone into preparing the written presentations and those that you made here. I must say that this was a very harmonious group and I hope you found each other very agreeable. I certainly thought that we had collected a very fine set of people. They were all experts and we had a very useful and in-depth discussion on various matters. I hope we can continue with this and we will probably call upon you once again to join in some future workshop. So may I thank you very sincerely on behalf of the Authority and the members of the Authority for your contributions. I wish you Bon Voyage and I wish you well in your professions as you go home.

## Chapter 20

### CONCLUSIONS AND RECOMMENDATIONS

#### TECHNOLOGIES FOR DEEP SEABED EXPLORATION

**CONCLUSION:** The technology for manganese nodule exploration is appropriate and generally utilizes state-of-the-art equipment. In some cases the work carried out is building on earlier efforts but in general advances in technology or methodology have not been significant. Most exploration appears to be in support of environmental studies. The methods used are not standardized and there does not appear to be a lot of cross fertilization in this area, even though there should be little competitive concern among the pioneers.

**RECOMMENDATION:** pool the existing information among registered pioneer investors where there is no competitive concern. Non registered explorers be invited to contribute non confidential information, and research scientists be invited to contribute where ever possible.

#### TECHNOLOGIES FOR DEEP SEABED EXPLOITATION

**CONCLUSION:** A great deal of interesting and sophisticated engineering work has been applied by the individual pioneers in support of national R&D programmes. Much of it appears to be duplicative and while a certain amount has been a necessary learning experience, there is a suggestion that we may have been reinventing the wheel. On the other hand, there was a near consensus that selected sites might be marginally economic at this time, and perhaps even profitable. A well designed and managed operation might pay for itself and provide the experience needed to all participants.

**RECOMMENDATION:** The Authority should encourage the pioneer investors to share existing technology, rank the systems already developed, and incorporate advanced and proven systems from other industries where appropriate. Steps should be taken to form a "Pilot Enterprise", being a consortium of investors working together in a mutually agreed upon site under the approval and guidance of the authority to develop a full-size, pilot mining operation.

## ACCOMPLISHMENTS OF REGISTERED PIONEER INVESTORS

**CONCLUSION:** The Pioneer Investors have brought themselves up to speed in general with great effort and expense and have significant accomplishments in a number of focused areas. Much of this effort has been directed to understanding and characterizing individual areas.

**RECOMMENDATION:** The pioneers should consider cooperative efforts to get together and pool technology, analyse all work accomplished to date and identify bottlenecks. For future work they might consider setting up joint cooperative agreements where possible and appropriate to eliminate duplication of work

## ENVIRONMENTAL ISSUES

**CONCLUSION:** Importance of environmental issues has been generally accepted and major efforts have been made to characterize the pioneer areas. However, these efforts are lacking in standardization and commonly agreed models for testing impacts. There is a danger of duplication of effort, using the wrong model. This is particularly true if deposits other than manganese nodules are considered as well.

**RECOMMENDATION:** A small team be selected under the auspices of the Authority, to analyze in detail the information and findings from the Sanya workshop and develop an appropriate model or models that can be used by all involved parties. Prior to publication this document should be circulated, for review and comment, to appropriate persons and organizations on an international basis. The final publication should serve as a standard of excellence for use by the Authority and any other involved parties

## BOTTLENECKS IN RESEARCH

**CONCLUSION:** Successes have been amply discussed but failures and bottlenecks have not always been given the credit they deserve on the learning curve and mistakes are sometimes repeated. This applies to both technological and environmental research.

**RECOMMENDATION:** Again, a small team should be put together to study this issue. The most important effort is the inputs given to the leader to formulate a guidance document for future research activities. This particularly applies to standardization of data collection, data evaluation, and storage and retrieval of data and information. The document should be reviewed on an international basis by appropriate individuals selected from governments, industries, universities, and the lay public.



## THE CHALLENGES AHEAD

**CONCLUSION:** The restricted field of technology for the development of manganese nodules in the Area beyond national jurisdiction has been blown apart by the proliferation of advanced and adaptive technologies in other fields and for other resources including, but not limited to: metalliferous sulfides, cobalt crusts, deepwater oil and gas, hydrates, diamonds, sand and gravel, aerospace, medicine, computer science and biotechnology.

**RECOMMENDATION:** The Authority should continue its excellent work in broadening the scope of its authorized activities by additional workshops, internet communications, encouragement of joint research among universities, governments and industry, and the appointment of small teams to report and recommend action on special issues of immediate and future concern.

## SCOPE FOR COOPERATION

**CONCLUSION:** The value of cooperation and the development of consortia is an accepted way of sharing risk where the investments are too great for any one organization to commit. Past efforts that began the intensive research and development efforts for manganese nodules as a commercial venture were successful in their accomplishments even though unsuccessful in their final goal. Despite the expenditures of over \$600 million, with no return, none of the 36 organizations involved was bankrupted by their actions. In the case where there is no true need for competition, then cooperative, or joint ventures are useful, cost saving and positive actions. Some of the recent activities of pioneer investors appear to have been directed to non-sharing R&D efforts perhaps for nationalistic or inappropriate reasons which may have led to much duplication of effort and expense.

**RECOMMENDATION:** In keeping with Article 136 of the Convention that the Area and its resources are the common heritage of mankind, the Authority should continue and even accelerate its efforts to encourage pioneer investors and others to partner in resource development activities within the Area with the least possible imposition of costs to the operators that may be appropriate.

## THE USA SITUATION

CONCLUSION: Though only briefly discussed it was obvious that the situation regarding claims of United States' industry within the CCFZ, made under U.S. legislation and in cooperation with the UN Seabeds Committee was quite anomalous at this time as the U.S. had not yet signed the Treaty. Future actions planned by the U.S. or the U.N. were not known or discussed.

RECOMMENDATION: None.

## THE WORKSHOP

CONCLUSION: The workshop was excellently attended and all participants contributed most strongly to its success, giving freely of their knowledge and understanding of the issues. The information presented was in many instances unique and without the experience and generosity of the speakers might never have been recorded.

RECOMMENDATION: The usefulness of the workshop was without doubt and it followed as an excellent complement to the recent Sanya workshop on environmental issues. The forum should be repeated in the near future to consider further progress in the development of minerals other than manganese nodules.



# Appendices

## **Appendix A**

398

International Seabed Authority Fourth Session.  
Plans of work for exploration of the Government of India,  
Institut français de recherche pour l'exploitation de la mer (Ifremer)/  
Association française pour l'étude et la recherche des nodules  
(Afernod) (France), Deep Ocean Resources Development Co. Ltd.  
(DORD)(Japan), Yuzhmorgeologiya (Russian Federation), China  
Ocean Minerals Research and Development Association  
(COMRA) (China), Interoceanmetal Joint Organization (IOM)  
(Bulgaria, Cuba, Czech Republic, Poland, Russian Federation and  
Slovakia) and the Government of the Republic of Korea.

## **Appendix B**

Polymetallic Nodules Database – POLYDAT  
- Secretariat, ISA

447

## Appendix A

INTERNATIONAL SEABED AUTHORITY

Assembly

Distr. GENERAL

ISBA/4/A/1/Rev.2 2 September 1998 ORIGINAL: ENGLISH

INTERNATIONAL SEABED AUTHORITY

Resumed fourth session

Kingston, Jamaica

17-28 August 1998

PLANS OF WORK FOR EXPLORATION OF THE GOVERNMENT OF INDIA, INSTITUT FRANCAIS DE RECHERCHE POUR L'EXPLOITATION DE LA MER(IFREMER)/ ASSOCIATION FRANCAISE POUR L'ETUDE ET LA RECHERCHE DES NODULES (AFERNOD) (FRANCE), DEEP OCEAN RESOURCES DEVELOPMENT CO. LTD. (DORD)(JAPAN), YUZHMOREGEOLOGIYA (RUSSIAN FEDERATION), CHINA OCEAN MINERAL RESOURCES RESEARCH AND DEVELOPMENT ASSOCIATION (COMRA)(CHINA), INTEROCEANMETAL JOINT ORGANIZATION (IOM)(BULGARIA, CUBA, CZECH REPUBLIC, POLAND, RUSSIAN FEDERATION AND SLOVAKIA) AND THE GOVERNMENT OF THE REPUBLIC OF KOREA

### REPORT OF THE SECRETARY-GENERAL

1. The purpose of the present report is to provide to all members of the Authority information of a general nature regarding plans of work for exploration submitted by the following registered pioneer investors in accordance with paragraph 6 (a) (ii) of section 1 of the annex to the Agreement relating to the implementation of Part XI of the United Nations Convention on the Law of the Sea of 10 December 1982 ("the Agreement"): the Government of India, Institut français de

recherche pour l'exploitation de la mer (Ifremer)/ Association française pour l'étude et la recherche des nodules (Afernod) (France), Deep Ocean Resources Development Co. Ltd. (DORD)(Japan), Yuzhmorgeologiya (Russian Federation), China Ocean Minerals Research and Development Association (COMRA)(China), Interoceanmetal Joint Organization (IOM)(Bulgaria, Cuba, Czech Republic, Poland, Russian Federation and Slovakia) and the Government of the Republic of Korea.

2. On 19 August 1997, requests for approval of plans of work for exploration were submitted by the aforementioned registered pioneer investors in accordance with paragraph 6 (a) (ii) of section 1 of the annex to the Agreement.

3. In accordance with paragraph 6(a)(ii) of section 1 of the annex to the Agreement, in the case of a registered pioneer investor, the plan of work for exploration shall consist of documents, reports and other data submitted to the Preparatory Commission for the International Seabed Authority and for the International Tribunal for the Law of the Sea ("the Preparatory Commission") both before and after registration and shall be accompanied by a certificate of compliance, consisting of a factual report describing the status of fulfilment of obligations under the pioneer investor regime, issued by the Preparatory Commission in accordance with resolution II, paragraph 11(a). Such a plan of work shall be considered to be approved.

4. On 21 August 1997, I referred the requests for approval of plans of work for exploration submitted by the aforementioned registered pioneer investors to the Legal and Technical Commission.

5. On the same date, I informed the Commission that I had ascertained that:

(a) The documents, reports and other data submitted to the Preparatory Commission both before and after registration are available;

(b) The certificate of compliance, consisting of a factual report describing the status of fulfilment of obligations under the registered pioneer investor regime, issued by the Preparatory Commission in accordance with resolution II, paragraph 11 (a), of the Third United Nations Conference on the Law of the Sea, had been produced. In the case of the Republic of Korea, however, which was not able to obtain a certificate of compliance before the Preparatory Commission concluded its work, a statement describing the status of the implementation of the obligations of the registered pioneer investor was issued in lieu of the certificate of compliance (ISBA/3/C/6);

(c) The registered pioneer investor has updated the information provided in the documents, reports and other data submitted to the Preparatory Commission both before and after registration and had submitted its programme of work for the immediate future, including a general assessment of the potential environmental impacts of the proposed activities; and

(d) The registered pioneer investor has given a written undertaking that it will:

- (i) Accept as enforceable and comply with the applicable obligations created by the provisions of the Convention and the rules, regulations and procedures of the Authority, the decisions of the organs of the Authority and the terms of its contracts with the Authority;
- (ii) Accept control by the Authority of activities in the Area, as authorized by the Convention; and
- (iii) Provide the Authority with a written assurance that its obligations under the contract would be fulfilled in good faith.

6. On 22 August 1997, the Legal and Technical Commission transmitted to the Council its report and recommendation on the requests for approval of plans of work for exploration submitted by the aforementioned registered pioneer investors (ISBA/3/C/7). On 28 August 1997, the Council, noting the report of the Legal and Technical Commission, and further noting that in accordance with paragraph 6 (a) (ii) of section 1 of the annex to the Agreement the plans of work are considered to be approved, requested the Secretary-General to take the necessary steps to issue the plans of work in the form of contracts incorporating the applicable obligations under the provisions of the Convention, the Agreement and resolution II, and in accordance with the regulations on prospecting and exploration for polymetallic nodules in the Area and a standard form of contract to be approved by the Council (ISBA/3/C/9).

7. Information of a general nature regarding the requests for approval of plans of work for exploration submitted by the registered pioneer investors is contained in annexes I to VII to the present report, together with lists of the documents and reports of the Preparatory Commission relevant to the plans of work for exploration. The relevant documents and reports of the Preparatory Commission are contained in the report of the Preparatory Commission under paragraph 11 of resolution I to the Assembly of the International Seabed Authority (LOS/PCN/153, vols. I and III).

8. The consolidated provisional final report of the Preparatory Commission dated 30 June 1995 (LOS/PCN/153, vol.I) also contains a full description of the procedures and mechanisms for registration of the pioneer investors pursuant to resolution II as well as details of the implementation of the obligations of the registered pioneer investors pursuant to resolution II and related understandings.



## **Annex I**

### **GOVERNMENT OF INDIA**

#### **Part I**

##### **Information concerning the registered pioneer investor**

1. Name of the registered pioneer investor: The Republic of India.
2. Address: Department of Ocean Development, Block-XII, CGO Complex, Lodi Road, New Delhi - 110 003, India.
3. Telephone number: (91) (11) 436 08 74 and 436 14 36.
4. Facsimile number: (91) (11) 436 26 44 and 436 03 36.
5. Electronic mail address: aem@dod12.ernet.in.
6. Name of designated representative: Dr. A. E. Muthunayagam.
7. Date of deposit of instrument of ratification of the 1982 United Nations Convention on the Law of the Sea and of consent to be bound by the Agreement relating to the Implementation of Part XI of the 1982 United Nations Convention on the Law of the Sea of 10 December 1982: 29 June 1995.
8. A certificate of compliance was issued by the Preparatory Commission on 14 March 1995 in accordance with resolution II, paragraph 11(a) of the Third United Nations Conference on the Law of the Sea.

#### **Part II**

##### **Information relating to the area allocated to the registered pioneer investor**

9. The area allocated to the Republic of India is bounded by lines joining the following turning points, the coordinates of which are listed below:

Turning points	Latitude (S)	Longitude (E)
A1	10° 45'	73° 00'
A2	10° 45'	74° 15'
A3	10° 30'	74° 15'
A4	10° 30'	74° 30'
A5	10° 15'	74° 30'
A6	10° 15'	75° 00'
A7	10° 00'	75° 00'
A8	10° 00'	76° 15'
A9	10° 15'	76° 15'
A10	10° 15'	75° 45'
A11	10° 30'	75° 45'
A12	10° 30'	76° 00'
A15	11° 30'	75° 30'
A16	11° 30'	76° 00'
A17	11° 45'	76° 00'
A18	11° 45'	76° 30'
A19	13° 30'	76° 30'
A20	13° 30'	76° 15'
A21	13° 45'	76° 15'
A22	13° 45'	76° 00'
A23	14° 00'	76° 00'
A24	14° 00'	75° 30'
A25	16° 15'	75° 30'
A26	16° 15'	75° 15'
A27	15° 45'	75° 15'
A28	15° 45'	75° 00'
A29	15° 15'	75° 00'
A30	15° 15'	75° 15'
A31	15° 00'	75° 15'
A32	15° 00'	75° 00'
A33	14° 45'	75° 00'
A34	14° 45'	74° 45'
A35	14° 30'	74° 45'
A36	14° 30'	73° 15'
A37	14° 15'	73° 15'
A38	14° 15'	73° 00'
A39	14° 00'	73° 00'
A40	14° 00'	73° 30'
A41	13° 45'	73° 30'
A42	13° 45'	73° 45'
A43	13° 30'	73° 45'

Turning points	Latitude (S)	Longitude (E)
A44	13° 30'	74° 30'
A45	12° 30'	74° 30'
A46	12° 30'	74° 45'
A47	12° 15'	74° 45'
A48	12° 15'	75° 00'
A49	11° 45'	75° 00'
A50	11° 45'	74° 30'
A51	11° 15'	74° 30'
A52	11° 15'	73° 45'
A53	11° 45'	73° 45'
A54	11° 45'	72° 45'
A55	11° 15'	72° 45'
A56	11° 15'	73° 00'
A1	10° 45'	73° 00'
A57	10° 45'	78° 30'
A58	10° 30'	78° 30'
A59	10° 30'	79° 15'
A60	11° 00'	79° 15'
A61	11° 00'	79° 00'
A62	14° 00'	79° 00'
A63	14° 00'	78° 45'
A64	14° 30'	78° 45'
A65	14° 30'	78° 15'
A66	14° 00'	78° 15'
A67	14° 00'	78° 30'
A68	13° 00'	78° 30'
A69	13° 00'	78° 15'
A70	11° 15'	78° 15'
A71	11° 15'	78° 00'
A72	11° 00'	78° 00'
A73	11° 00'	78° 15'
A74	10° 45'	78° 15'
A57	10° 45'	78° 30'

10. The general location of the area allocated to the Republic of India and the areas subsequently relinquished by it are shown in figure 1.

11. The Republic of India relinquished 20 per cent of the area allocated to it on 3 August 1994 (LOS/PCN/BUR/R.44) and a further 10 per cent of the area on 12 November 1997 (ISBA/4/LTC/R.1). [LOS/PCN/L.41/Rev.1, annex, paragraph 13(3), requires India to conform to the provisions on relinquishment of resolution II. Under those provisions, India, which became a registered pioneer investor on 17

August 1987, was due to relinquish 20 per cent of its allocated area by 17 August 1990 and a further 10 per cent of the area allocated by 17 August 1992.]

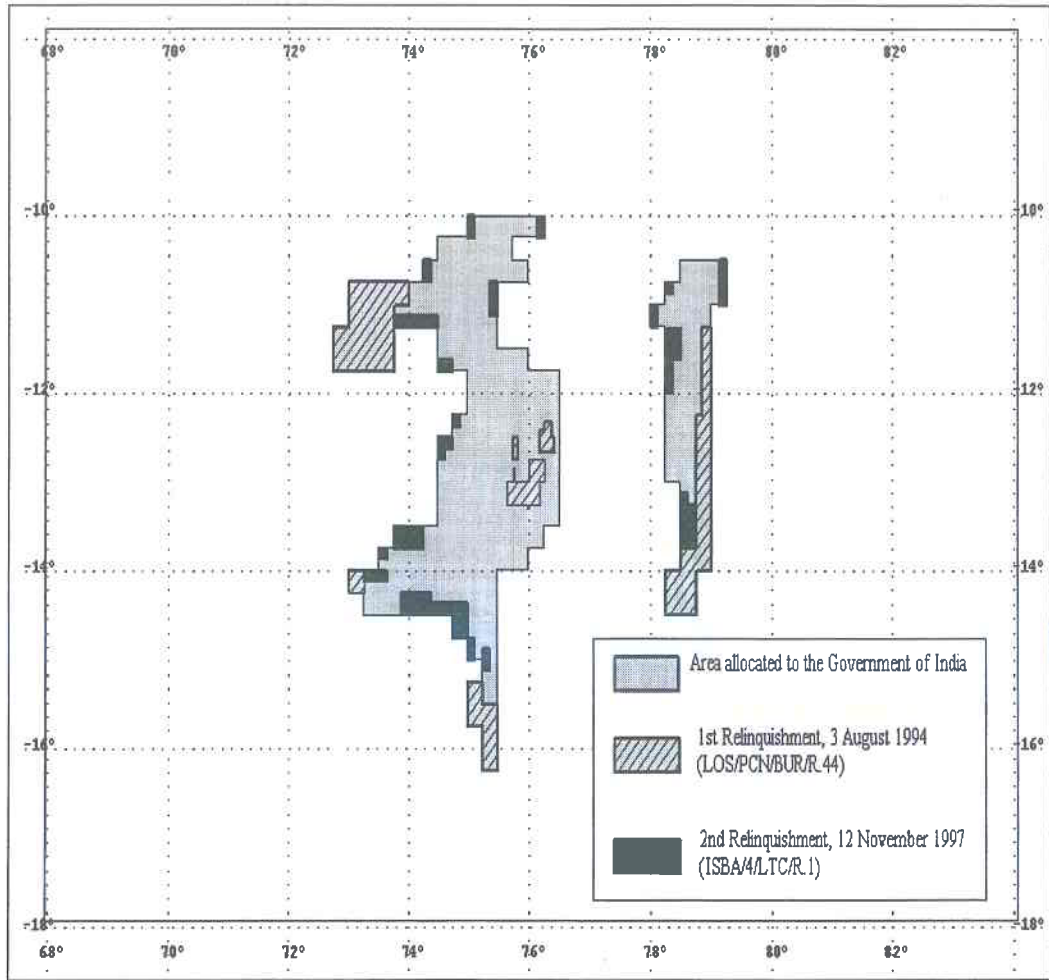

Figure 1 - Area allocated to Republic of India

### Part III

#### Documents, reports and other data relevant to the plan of work

12. The following are documents and reports of the Preparatory Commission relevant to the plan of work:

- (a) Receipt of application from India for registration as a pioneer investor under resolution II of the Third United Nations Conference on the Law of the Sea. Note by the Secretary-General (LOS/PCN/32, 14 February 1984);

(b) Receipt of a revised application from the Government of India for registration as a pioneer investor under resolution II of the Third United Nations Conference on the Law of the Sea. Note by the Secretary-General (LOS/PCN/87, 23 July 1987);

(c) Report of the Group of Technical Experts to the General Committee of the Preparatory Commission on the application of the Government of the Republic of India for registration as a pioneer investor under resolution II (LOS/PCN/BUR/R.1, 10 August 1987);

(d) Decision adopted on 17 August 1987 by the General Committee of the Preparatory Commission on the application of the Government of India as a pioneer investor under resolution II (LOS/PCN/94, 9 October 1987 and Corr.1, 23 October 1987);

(e) Certificate of Registration issued to the Government of India as a pioneer investor dated 18 December 1987;

(f) Report on the status on the implementation of the obligations of the registered pioneer investors under resolution II and the related understandings prepared by the Secretariat (LOS/PCN/145, 23 September 1994).

13. The following documents and reports were submitted by the Government of India to the Preparatory Commission both before and after registration:

(a) Periodic report on the activities of India in the pioneer area (LOS/PCN/BUR/R.11, 27 February 1992);

(b) Periodic report on the activities of India in the pioneer area (LOS/PCN/BUR/R.24, 25 March 1993);

(c) Relinquishment of pioneer areas (resolution II, paragraph 1 (e) (LOS/PCN/BUR/R.44, 3 August 1994);

(d) The training programme of India (extract from LOS/PCN/153/vol. IV, p. 26, pars. 59-65, 26 June 1995);

(e) Report on the training of two trainees in India. (LOS/PCN/TP/1994/CRP.27, 2 August 1997);

(f) Report on relinquishment of 10 per cent of the pioneer area submitted by India on 12 November 1997 (ISBA/4/LTC/R.1, 16 December 1997);\*

(g) Periodic report on the activities of the Government of India in the pioneer area, for the period 1994 to 1997 (ISBA/4/LTC/R.3, 21 August 1998).\*

---

\* The Preparatory Commission concluded its work upon entry into force of the Convention on November 16, 1994. Reports submitted by registered pioneer investors pursuant to resolution II after the Preparatory Commission concluded its work have been issued under the symbol "ISBA" as documents of the Legal and Technical Commission

## Annex II

### IFREMER/AFERNOD

#### Part I

##### Information concerning the registered pioneer investor

1. Name of the registered pioneer investor: "Institute français de recherche pour l'exploitation de la mer (IFREMER)" on behalf of "l'Association française pour l'étude et la recherche des nodules (AFERNOD)", designated hereinafter as IFREMER/AFERNOD.
2. Address: IFREMER/AFERNOD, 155, rue Jean-Jacques Rousseau, 92138 Issy-les-Moulineaux cedex, France.
3. Telephone number: (33) (1) 46 48 22 00.
4. Facsimile number: (33) (1) 46 48 22 24.
5. Electronic mail address: Guy.Herrouin@ifremer.fr.
6. Sponsoring State: France.
7. Date of deposit of instrument of ratification of the 1982 United Nations Convention on the Law of the Sea: 11 April 1996.
8. Date of consent to be bound by the Agreement relating to the Implementation of Part XI of the 1982 United Nations Convention on the Law of the Sea of 10 December 1982: 11 April 1996.
9. A certificate of compliance was issued by the Preparatory Commission on 14 March 1995 in accordance with resolution II, paragraph 11 (a) of the Third United Nations Conference on the Law of the Sea.

## Part II

### Information relating to the area allocated to the registered pioneer investor

10. The area allocated to IFREMERM/AFERNOD is bounded by lines joining the following turning points, the coordinates of which are listed below:

Turning points	Latitude (N)	Longitude (W)
North-East Area		
1	16°00.00'	129°18.00'
2	16°00.00'	128°35.00'
3	15°30.00'	128°35.00'
4	15°20.00'	129°18.00'
1	16°00.00'	129°18.00'
South-East Area		
1	15°20.00'	132°00.00'
2	15°20.00'	131°00.00'
3	15°00.00'	131°00.00'
4	15°00.00'	128°35.00'
5	13°58.00'	128°35.00'
6	13°58.00'	129°10.00'
7	13°55.00'	129°10.00'
8	13°55.00'	130°00.00'
9	13°45.00'	130°00.00'
10	13°45.00'	131°10.00'
11	14°20.00'	131°10.00'
12	14°20.00'	131°30.00'
13	14°40.00'	131°30.00'
14	14°40.00'	132°00.00'
1	15°20.00'	132°00.00'
West Area		
1	9°44.933'	151°00.00'
2	9°44.933'	149°30.00'
3	8°40.00'	149°30.00'
4	8°40.00'	149°45.00'
5	8°15.00'	149°45.00'
6	8°15.00'	151°00.00'
1	9°44.933'	151°00.00'

11. The general location of the area allocated to IFREMERM/AFERNOD is shown in figure 2.



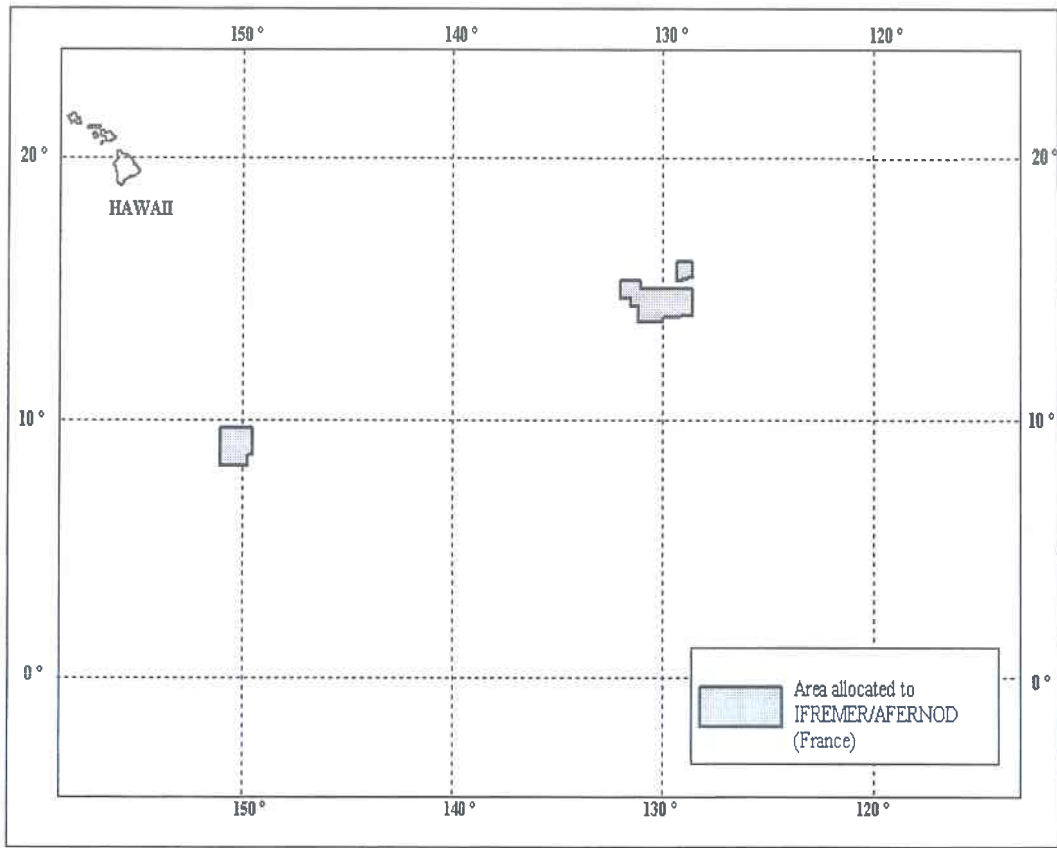

Figure 2 - Area allocated to IFREMER/AFERNOD (France)

12. IFREMER/AFERNOD has completed its programme of relinquishment. [In document LOS/PCN/L.41/Rev.1, annex, it is stated that applicants which had relinquished in advance portions of the application area simultaneously with the application shall be deemed to have complied with resolution II, paragraph 1 (e). This applies to France, Japan and the Russian Federation. (LOS/PCN/145).]

### Part III

#### Documents, reports and other data relevant to the plan of work

13. The following are documents and reports of the Preparatory Commission\* relevant to the plan of work:

(a) Receipt of application from the Government of France for registration of the Association française pour l'étude et la recherche des nodules (AFERNOD) as a

pioneer investor under resolution II of the Third United Nations Conference on the Law of the Sea. Note by the Secretary-General (LOS/PCN/51, 23 August 1984);

(b) Receipt of a revised application from the Government of France for the registration as pioneer investor under resolution II of the Third United Nations Conference on the Law of the Sea. Note by the Secretary-General (LOS/PCN/89, 23 July 1987);

(c) Report of the Group of Technical Experts to the General Committee of the Preparatory Commission on the application of the Government of the Republic of France for registration as a pioneer investor under resolution II of the Third United Nations Conference on the Law of the Sea (LOS/PCN/BUR/R.2, 4 December 1987);

(d) Decision adopted on 17 December 1987 by the General Committee of the Preparatory Commission on the application of the Government of France as a pioneer investor under resolution II of the Third United Nations Conference on the Law of the Sea (LOS/PCN/97, 6 January 1988);

(e) Certificate of registration issued to IFREMER/AFERNOD as a pioneer investor dated 16 May 1988;

(f) Report on the status of the implementation of the obligations of the registered pioneer investors under resolution II and the related understandings. Prepared by the Secretariat (LOS/PCN/145, 23 September 1994).

14. The following documents and reports were submitted by IFREMER/AFERNOD to the Preparatory Commission both before and after registration:

(a) Report on "Preparatory Work in the International Seabed Authority reserved area - August 1991", prepared jointly by the registered pioneer investors IFREMER/AFERNOD (France), DORD (Japan) and Yuzhmorgeologiya (Russian Federation);

(b) Training programme for the Preparatory Commission, as required of pioneer investors (LOS/PCN/TP/1991/CRP.2, 14 August 1991);

(c) Periodic report on the activities of IFREMER/AFERNOD in the pioneer area (LOS/PCN/BUR/R.13, 2 March 1992);

(d) Report on the implementation of the French training programme (LOS/PCN/TP/1993/CRP.16, 23 March 1993);

(e) Periodic report on the activities of IFREMER / AFERNOD in the pioneer area for the period 1 January-31 December 1992 (LOS/PCN/BUR/R.22, 23 March 1993);

(f) Periodic report on the activities of IFREMER / AFERNOD in the pioneer area for the period 1 January-31 December 1993. Submitted by the delegation of France (LOS/PCN/BUR/R.31, 31 January 1994);

(g) Letter dated 28 January 1994 from the Chairman of the delegation of France addressed to the Chairman of the Preparatory Commission concerning the training course completed in France by one trainee (LOS/PCN/136, 9 February 1994);

(h) Report on training of three fellows in France (LOS/PCN/TP/1994/CRP.26, 25 July 1994).

---

\* The Preparatory Commission concluded its work upon entry into force of the Convention on November 16, 1994. Reports submitted by registered pioneer investors pursuant to resolution II after the Preparatory Commission concluded its work have been issued under the symbol "ISBA" as documents of the Legal and Technical Commission.

## **Annex III**

### **DEEP OCEAN RESOURCES DEVELOPMENT CO., LTD.**

#### **Part I**

##### **Information concerning the registered pioneer investor**

1. Name of the registered pioneer investor: Deep Ocean Resources Development Co., Ltd. (DORD).
2. Address: 21-19, Toranomom 1-Chome, Minato-Ku, Tokyo, 105, Japan.
3. Telephone number: (3) 5510 3057.
4. Facsimile number: (3) 3593 3324.
5. Electronic mail address: dord@tka.att.ne.jp.
6. Name of designated representative: Takeo Kuroko, President of DORD.
7. Place of registration: Tokyo, Japan.
8. Principal place of business: Tokyo, Japan.
9. Sponsoring State: Japan.
10. Date of deposit of instrument of ratification of the 1982 United Nations Convention on the Law of the Sea and of consent to be bound by the Agreement relating to the Implementation of Part XI of the 1982 United Nations Convention on the Law of the Sea of 10 December 1982: 20 June 1996.
11. A certificate of compliance was issued by the Preparatory Commission on 14 March 1995 in accordance with resolution II, paragraph 11 (a) of the Third United Nations Conference on the Law of the Sea.

## Part II

### Information relating to the area allocated to the registered pioneer investor

12. The area allocated to DORD is bounded by lines joining the following turning points, the coordinates of which are listed below:

West Area Turning points	Latitude (N)	Longitude (W)
1	11°00'	149°15'
2	11°00'	148°30'
3	10°48.75'	148°30'
4	10°48.75'	147°30'
5	11°00'	147°30'
6	11°00'	147°00'
7	10°45'	147°00'
8	10°45'	146°45'
9	11°00'	146°45'
10	11°00'	146°07.5'
11	11°03.75'	146°07.5'
12	11°03.75'	145°48.75'
13	10°11.25'	145°48.75'
14	10°11.25'	146°15'
15	10°22.5'	146°15'
16	10°22.5'	146°32'
17	10°07.5'	146°32'
18	10°07.5'	146°45'
19	09°37.5'	146°45'
20	09°37.5'	146°30'
21	09°22.5'	146°30'
22	09°22.5'	146°00'
23	8°45'	146°00'
24	8°45'	147°44.8'
25	10°00'	147°44.8'
26	10°00'	148°30'
27	10°15'	148°30'
28	10°15'	149°30'
29	10°45'	149°30'
30	10°45'	149°15'
1	11°00'	149°15'

East Area Turning points	Latitude (N)	Longitude (W)
1	15°39'	132°55'
2	15°39'	132°00'
3	15°45'	132°00'
4	15°45'	131°00'
5	15°20'	131°00'
6	15°20'	132°00'
7	14°40'	132°00'
8	14°17.4'	132°48'
9	14°17.4'	132°55'
1	15°39'	132°55'

13. The general location of the area allocated to DORD is shown in figure 3.

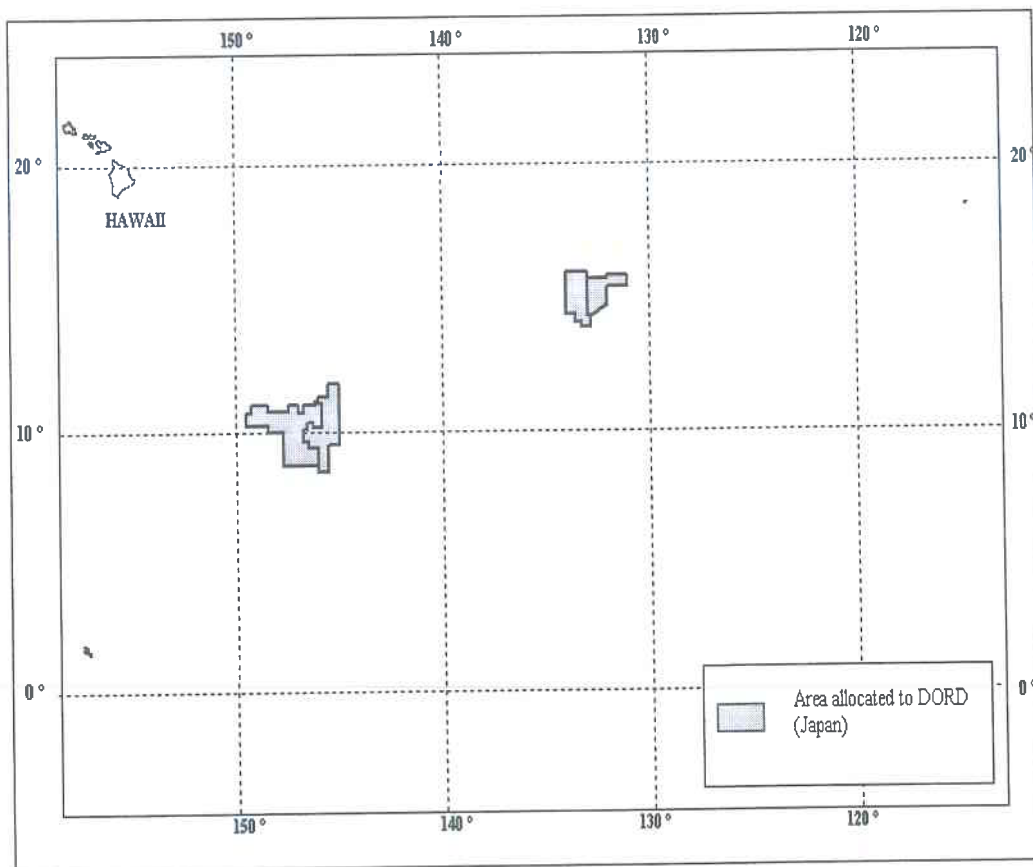

Figure 3 - Area allocated to DORD (Japan)

14. DORD has completed its programme of relinquishment. [In document LOS/PCN/L.41/Rev.1, annex, it is stated that applicants which had relinquished in advance portions of the application area simultaneously with the application shall be deemed to have complied with resolution II, paragraph 1 (e). This applies to France, Japan and the Russian Federation (LOS/PCN/145).]

### Part III

#### Documents, reports and other data relevant to the plan of work

15. The following are documents and reports of the Preparatory Commission\* relevant to the plan of work:

(a) Receipt of application from the Government of Japan for registration of the Japanese enterprise Deep Ocean Resources Development Co., Ltd. as a pioneer investor under resolution II of the Third United Nations Conference on the Law of the Sea. Note by the Secretary-General (LOS/PCN/50, 22 August 1984);

(b) Receipt of a revised application from the Government of Japan for registration of the Japanese enterprise Deep Ocean Resources Development Company, Ltd. as a pioneer investor under resolution II of the Third United Nations Conference on the Law of the Sea. Note by the Secretary-General (LOS/PCN/86, 23 July 1987);

(c) Report of the Group of Technical Experts to the General Committee of the Preparatory Commission on the application of the Government of Japan for registration as a pioneer investor under resolution II of the Third United Nations Conference on the Law of the Sea (LOS/PCN/BUR/R.3, 4 December 1987);

(d) Decision adopted on 17 December 1987 by the General Committee of the Preparatory Commission on the application of the Government of Japan as a pioneer investor under resolution II of the Third United Nations Conference on the Law of the Sea (LOS/PCN/98, 6 January 1988);

(e) Certificate of registration issued to DORD as a pioneer investor dated 16 May 1988;

(f) Report on the status of the implementation of the obligations of the registered pioneer investors under resolution II and the related understandings. Prepared by the Secretariat (LOS/PCN/145, 23 September 1994);

16. The following documents and reports were submitted by DORD to the Preparatory Commission\* both before and after registration:

(a) Report on "Preparatory Work in the International Seabed Authority Reserved Area - August 1991", prepared jointly by the registered pioneer investors IFREMER/AFERNOD (France), DORD (Japan) and Yuzhmorgeologiya (Russian Federation);

(b) Information on a revised training programme (LOS/PCN/TP/1992/CRP.5, 24 January 1992 and Corr.1);

(c) Periodic report on the activities of Deep Ocean Resources Development Co., Ltd. in the pioneer area (LOS/PCN/BUR/R.12, 28 February 1992);

(d) Periodic report on the activities of Deep Ocean Resources Development Co., Ltd. in the pioneer area (LOS/PCN/BUR/R.12/Corr.1, 4 March 1992);

(e) Periodic report on the activities of Deep Ocean Resources Development Co., Ltd. in the pioneer area (LOS/PCN/BUR/R.23, 25 March 1993);

(f) Periodic report on the activities of Deep Ocean Resources Development Co., Ltd. in the pioneer area (LOS/PCN/BUR/R.35, 7 February 1994);

(g) Report on the training of three trainees in Japan. (LOS/PCN/TP/1994/CRP.24, 21 July 1994).

---

\* The Preparatory Commission concluded its work upon entry into force of the Convention on November 16, 1994. Reports submitted by registered pioneer investors pursuant to resolution II after the Preparatory Commission concluded its work have been issued under the symbol "ISBA" as documents of the Legal and Technical Commission.



## **Annex IV**

### **YUZHMOREGEOLOGIYA**

#### **Part I**

##### **Information concerning the registered pioneer investor**

1. Name of the registered pioneer investor: State enterprise Yuzhmorgeologiya.
2. Address: 79, Krasnogvarrdeiskaya St., Gelendzhik, 353470, Russian Federation.
3. Telephone number: (7) (861) 41 243 31.
4. Facsimile number: (7) (861) 41 243 34.
5. Electronic mail address: postmaster@gpung.sea.ru.
6. Name of designated representative: Alexandr Michilovitch Ignatov, Director-General, Yuzhmorgeologiya.
7. Place of registration: Gelendzhik.
8. Principal place of business: Gelendzhik.
9. Sponsoring State: Russian Federation.
10. Date of deposit of instrument of ratification of the 1982 United Nations Convention on the Law of the Sea and of consent to be bound by the Agreement relating to the Implementation of Part XI of the 1982 United Nations Convention on the Law of the Sea of 10 December 1982: 12 March 1997.
11. A certificate of compliance was issued by the Preparatory Commission on 14 March 1995 in accordance with resolution II, paragraph 11 (a) of the Third United Nations Conference on the Law of the Sea.

## Part II

### Information relating to the area allocated to the registered pioneer investor

12. The area allocated to Yuzhmorgeologiya is bounded by lines joining the following turning points, the coordinates of which are listed below:

Turning points	Latitude (N)	Longitude (W)
1	12°31.10'	133°30.60'
2	12°50'	133°30.60'
3	12°50'	134°00'
4	13°00'	134°00'
5	13°00'	134°35'
6	12°00'	134°35'
7	12°00'	134°22.648'
8	11°30'	134°22.648'
9	11°30'	134°45'
10	13°30'	134°45'
11	13°30'	133°50'
12	13°34.805'	133°50'
13	13°34.805'	132°00'
14	4°40'	132°00'
15	14°40'	131°30'
16	14°20'	131°30'
17	14°20'	131°10'
18	13°45'	131°10'
19	13°45'	130°00'
20	13°55'	130°00'
21	13°55'	129°10'
22	13°58'	129°10'
23	13°58'	128°35'
24	14°45'	128°35'
25	14°45'	128°12.50'
26	14°37.50'	128°12.50'
27	14°37.50'	128°09.13'
28	14°15'	128°09.13'

Turning points	Latitude (N)	Longitude (W)
29	14°15'	128°05'
30	14°00'	128°05'
31	14°00'	128°10'
32	13°55'	128°10'
33	13°55'	128°15'
34	13°34.56'	128°15'
35	13°34.56'	128°35'
36	13°20.20'	128°35'
37	13°20.20'	130°00'
38	13°20'	130°00'
39	13°20'	131°00'
40	13°29'	131°00'
41	13°29'	132°15'
42	12°31.10'	132°15'
1	12°31.10'	133°30.60'
1	10°50'	143°00'
2	11°40'	143°00'
3	11°40'	142°00'
4	11°47.375'	142°00'
5	11°47.375'	141°37'
6	12°00'	141°37'
7	12°00'	141°25.172'
8	11°25'	141°25.172'
9	1°25'	141°55'
10	10°50'	141°55'
1	10°50'	143°00'

13. The general location of the area allocated to Yuzhmorgeologiya is shown in figure 4.

14. Yuzhmorgeologiya completed its relinquishment at the time of registration. [In document LOS/PCN/L.41/Rev.1, annex, it is stated that applicants which had relinquished in advance portions of the application area simultaneously with the application shall be deemed to have complied with resolution II, paragraph 1 (e). This applies to France, Japan and the Russian Federation (LOS/PCN/145).]

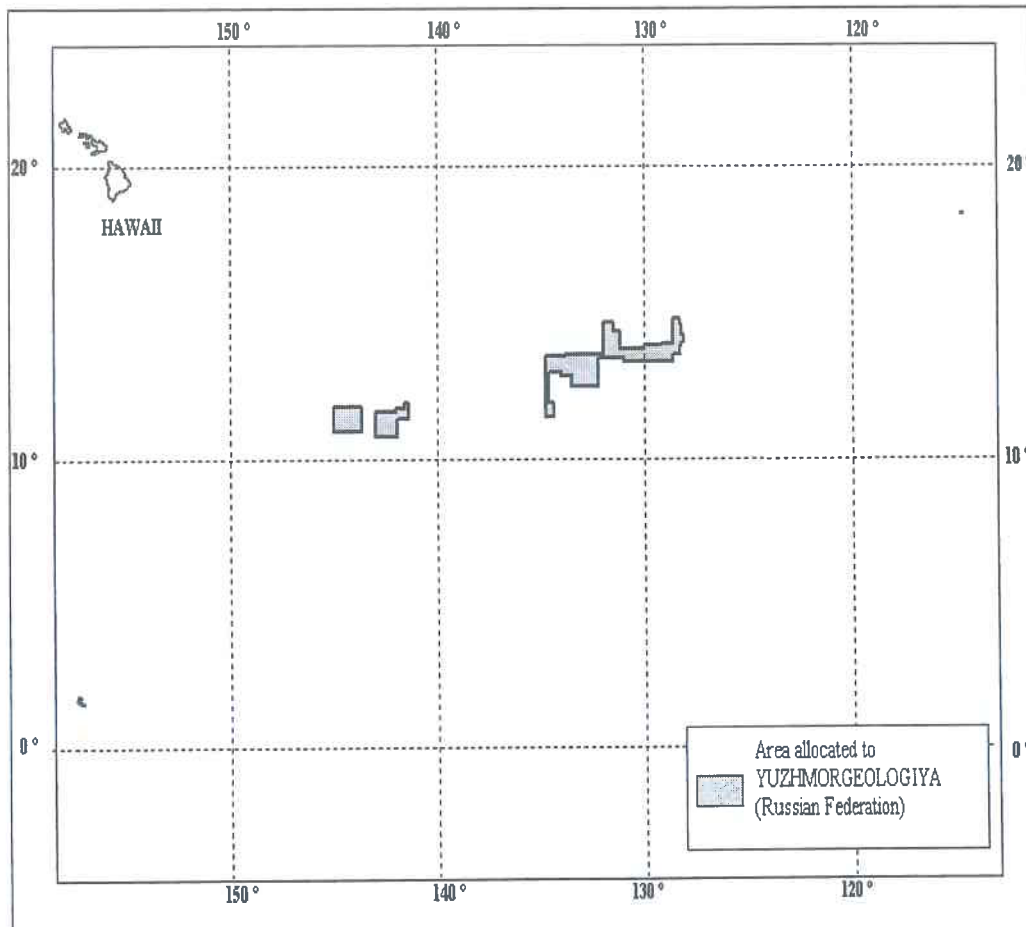

Figure 4 - Area allocated to YUZHMOREGEOLOGIYA

### Part III

#### Documents, reports and other data relevant to the plan of work

15. The following are documents and reports of the Preparatory Commission relevant to the plan of work:

(a) Letter dated 20 July 1983 from the Acting Permanent Representative of the Union of Soviet Socialist Republics to the United Nations addressed to the Chairman of the Preparatory Commission (LOS/PCN/30, 24 October 1983);

(b) Receipt of a revised application from the Government of the Union of Soviet Socialist Republics for the registration of the Soviet Enterprise "Yuzhmorgeologiya" as a pioneer investor (LOS/PCN/88, 23 July 1987);

(c) Report of the Group of Technical Experts to the General Committee of the Preparatory Commission on the application of the Government of the Union of Soviet Socialist Republics for registration as a pioneer investor under resolution II of the Third United Nations Conference on the Law of the Sea (LOS/PCN/BUR/R.4, 4 December 1987);

(d) Decision adopted on 17 December 1987 by the General Committee of the Preparatory Commission on the application of the Government of the Union of Soviet Socialist Republics as a pioneer investor under resolution II (LOS/PCN/99, 6 January 1988);

(e) Certificate of registration issued to Yuzhmorgeologiya as a pioneer investor dated 16 May 1988;

(f) Report on the status of the implementation of the obligations of the registered pioneer investors under resolution II and the related understandings. Prepared by the Secretariat (LOS/PCN/145, 23 September 1994);

16. The following documents and reports were submitted by Yuzhmorgeologiya to the Preparatory Commission both before and after registration:

(a) Report on "Preparatory work in the International Seabed Authority reserved area - August 1991", prepared jointly by the registered pioneer investors IFREMER/AFERNOD (France), DORD (Japan) and Yuzhmorgeologiya (Russian Federation);

(b) Periodic report on the activities of Yuzhmorgeologiya in the pioneer area (LOS/PCN/BUR/R.14, 6 March 1992 and Corr.1, 10 March 1992);

(c) Information on the training of personnel. Revised training programme submitted by the delegation of the Russian Federation (LOS/PCN/TP/1992/CRP.11, 7 August 1992);

(d) Periodic report on the activities of Yuzhmorgeologiya in the pioneer area for the period from 1 January to 31 December 1992 (LOS/PCN/BUR/R.25, 26 March 1993);

(e) Periodic report on the activities of Yuzhmorgeologiya in the pioneer area for the period from 1 January 1993 to 1 August 1994 (LOS/PCN/BUR/R.43, 2 August 1994);

(f) Report on training of three trainees in the Russian Federation (LOS/PCN/TP/1994/CRP.29, 3 August 1994);

(g) Letter dated 9 March 1995 from the Chairman of the delegation of the Russian Federation addressed to the Secretariat of the United Nations (LOS/PCN/151, 16 March 1995);

(h) Periodic report on the activities of Yuzhmorgeologiya in the pioneer area from 1 August 1994 to 1 August 1997 (ISBA/3/LTC/R.11, 22 August 1997).\*

\* The Preparatory Commission concluded its work upon entry into force of the Convention on November 16, 1994. Reports submitted by registered pioneer investors pursuant to resolution II after the Preparatory Commission concluded its work have been issued under the symbol "ISBA" as documents of the Legal and Technical Commission.

## **Annex V**

### **CHINA OCEAN MINERAL RESEARCH AND DEVELOPMENT ASSOCIATION**

#### **Part I**

##### **Information concerning the registered pioneer investor**

1. Name of the registered pioneer investor: China Ocean Mineral Research and Development Association (COMRA).
2. Address: 1 Fuxingmenwai Avenue, 100860, Beijing, China.
3. Telephone number: (86) (10) 6853 02 75 and 6853 33 18.
4. Facsimile number: (86) (10) 6853 02 75.
5. Electronic mail address: COMRA@Public.bta.net.cn.
6. Name of designated representative: JIN Jiancai.
7. Sponsoring State: People's Republic of China.
8. Date of deposit of instrument of ratification of the 1982 United Nations Convention on the Law of the Sea: 7 June 1996.
9. Date of consent to be bound by the Agreement relating to the Implementation of Part XI of the 1982 United Nations Convention on the Law of the Sea of 10 December 1982: 7 July 1996.
10. A certificate of compliance was issued by the Preparatory Commission on 14 March 1995 in accordance with resolution II, paragraph 11 (a) of the Third United Nations Conference on the Law of the Sea.

## Part II

### Information relating to the area allocated to the registered pioneer investor

11. The area allocated to COMRA is bounded by lines joining the following turning points, the coordinates of which are listed below:

Turning points	Latitude(N)	Longitude(W)
B1-1	10°52.50'	154°52.50'
B1-2	10°52.50'	154°22.50'
B1-3	11°07.50'	154°22.50'
B1-4	11°07.50'	154°07.50'
B1-5	10°52.50'	154°07.50'
B1-6	10°52.50'	153°52.50'
B1-7	10°22.50'	153°52.50'
B1-8	10°22.50'	153°37.50'
B1-9	10°07.50'	153°37.50'
B1-10	10°07.50'	153°22.50'
B1-11	09°37.50'	153°22.50'
B1-12	09°37.50'	153°07.50'
B1-13	09°22.50'	153°07.50'
B1-14	09°22.50'	152°52.50'
B1-15	09°37.50'	152°52.50'
B1-16	09°37.50'	152°37.50'
B1-17	09°52.50'	152°37.50'
B1-18	09°52.50'	152°54.83'
B1-19	10°07.50'	152°54.83'
B1-20	10°07.50'	152°37.50'
B1-21	10°22.50'	152°37.50'
B1-22	10°22.50'	152°52.50'
B1-23	10°37.50'	152°52.50'
B1-24	10°37.50'	153°22.50'
B1-25	10°52.50'	153°22.50'
B1-26	10°52.50'	152°22.50'
B1-27	11°22.50'	152°22.50'
B1-28	11°22.50'	151°52.50'
B1-29	11°07.50'	151°52.50'
B1-30	11°07.50'	152°07.50'
B1-31	10°22.50'	152°07.50'
B1-32	10°22.50'	151°22.50'
B1-33	10°52.50'	151°22.50'
B1-34	10°52.50'	151°07.50'



<b>Turning Points</b>	<b>Latitude(N)</b>	<b>Longitude(W)</b>
B1-35	09°52.50'	151°07.50'
B1-36	09°52.50'	151°37.50'
B1-37	09°37.50'	151°37.50'
B1-38	09°37.50'	151°07.50'
B1-39	09°10.00'	151°07.50'
B1-40	09°10.00'	151°52.50'
B1-41	09°22.50'	151°52.50'
B1-42	09°22.50'	152°22.50'
B1-43	09°10.00'	152°22.50'
B1-44	09°10.00'	152°55.20'
B1-45	08°52.50'	152°55.20'
B1-46	08°52.50'	153°37.50'
B1-47	09°07.50'	153°37.50'
B1-48	09°07.50'	153°52.50'
B1-49	08°52.50'	153°52.50'
B1-50	08°52.50'	154°00.00'
B1-51	08°37.50'	154°00.00'
B1-52	08°37.50'	154°37.50'
B1-53	08°22.50'	154°37.50'
B1-54	08°22.50'	154°52.50'
B1-55	08°52.50'	154°52.50'
B1-56	08°52.50'	154°37.50'
B1-57	09°07.50'	154°37.50'
B1-58	09°07.50'	154°52.50'
B1-1	10°52.50'	154°52.50'
B2-1	08°52.50'	148°52.50'
B2-2	08°52.50'	148°22.50'
B2-3	08°37.50'	148°22.50'
B2-4	08°37.50'	147°22.50'
B2-5	08°45.00'	147°22.50'
B2-6	08°45.00'	146°00.00'
B2-7	08°30.00'	146°00.00'
B2-8	08°30.00'	146°07.50'
B2-9	08°37.50'	146°07.50'
B2-10	08°37.50'	146°22.50'
B2-11	08°07.50'	146°22.50'
B2-12	08°07.50'	146°07.50'
B2-13	07°52.50'	146°07.50'
B2-14	07°52.50'	145°37.50'
B2-15	08°07.50'	145°37.50'
B2-16	08°07.50'	145°52.50'

Turning Points	Latitude(N)	Longitude(W)
B2-17	08°30.00'	145°52.50'
B2-18	08°30.00'	145°30.00'
B2-19	08°37.50'	145°30.00'
B2-20	08°37.50'	145°07.50'
B2-21	08°22.50'	145°07.50'
B2-22	08°22.50'	144°22.50'
B2-23	07°52.50'	144°22.50'
B2-24	07°52.50'	143°52.50'
B2-25	08°07.50'	143°52.50'
B2-26	08°07.50'	143°37.50'
B2-27	08°22.50'	143°37.50'
B2-28	08°22.50'	143°22.50'
B2-29	08°52.50'	143°22.50'
B2-30	08°52.50'	144°07.50'
B2-31	08°37.50'	144°07.50'
B2-32	08°37.50'	144°22.50'
B2-33	08°52.50'	144°22.50'
B2-34	08°52.50'	145°21.95'
B2-35	09°07.50'	145°21.95'
B2-36	09°07.50'	143°52.50'
B2-37	09°22.50'	143°52.50'
B2-38	09°22.50'	144°22.50'
B2-39	09°37.50'	144°22.50'
B2-40	09°37.50'	143°52.50'
B2-41	09°52.50'	143°52.50'
B2-42	09°52.50'	144°00.00'
B2-43	10°00.00'	144°00.00'
B2-44	10°00.00'	143°45.00'
B2-45	09°15.00'	143°45.00'
B2-46	09°15.00'	142°45.00'
B2-47	09°22.50'	142°45.00'
B2-48	09°22.50'	142°22.50'
B2-49	09°07.50'	142°22.50'
B2-50	09°07.50'	142°07.50'
B2-51	09°37.50'	142°07.50'
B2-52	09°37.50'	141°52.50'
B2-53	08°22.50'	141°52.50'
B2-54	08°22.50'	141°22.50'
B2-55	08°07.50'	141°22.50'
B2-56	08°07.50'	141°37.50'
B2-57	07°52.50'	141°37.50'

Turning Points	Latitude(N)	Longitude(W)
B2-58	07°52.50'	142°07.50'
B2-59	08°07.50'	142°07.50'
B2-60	08°07.50'	142°52.50'
B2-61	07°52.50'	142°52.50'
B2-62	07°52.50'	142°27.83'
B2-63	07°22.50'	142°27.83'
B2-64	07°22.50'	142°37.50'
B2-65	07°37.50'	142°37.50'
B2-66	07°37.50'	143°07.50'
B2-67	07°22.50'	143°07.50'
B2-68	07°22.50'	143°52.50'
B2-69	07°37.50'	143°52.50'
B2-70	07°37.50'	144°52.50'
B2-71	07°22.50'	144°52.50'
B2-72	07°22.50'	145°07.50'
B2-73	08°07.50'	145°07.50'
B2-74	08°07.50'	145°22.50'
B2-75	07°37.50'	145°22.50'
B2-76	07°37.50'	146°37.50'
B2-77	07°52.50'	146°37.50'
B2-78	07°52.50'	146°52.50'
B2-79	08°22.50'	146°52.50'
B2-80	08°22.50'	147°52.50'
B2-81	08°07.50'	147°52.50'
B2-82	08°07.50'	148°22.50'
B2-83	08°22.50'	148°22.50'
B2-84	08°22.50'	148°37.50'
B2-85	08°37.50'	148°37.50'
B2-86	08°37.50'	148°52.50'
B2-1	08°52.50'	148°52.50'

12. The general location of the area allocated to COMRA and the areas subsequently relinquished by it are shown in figure 5.

13. COMRA relinquished 30.05 per cent of its pioneer area on 5 March 1996 (ISBA/3/LTC/R.5\*\*, 28 April 1998) and will relinquish an additional 20 per cent before March 1999.

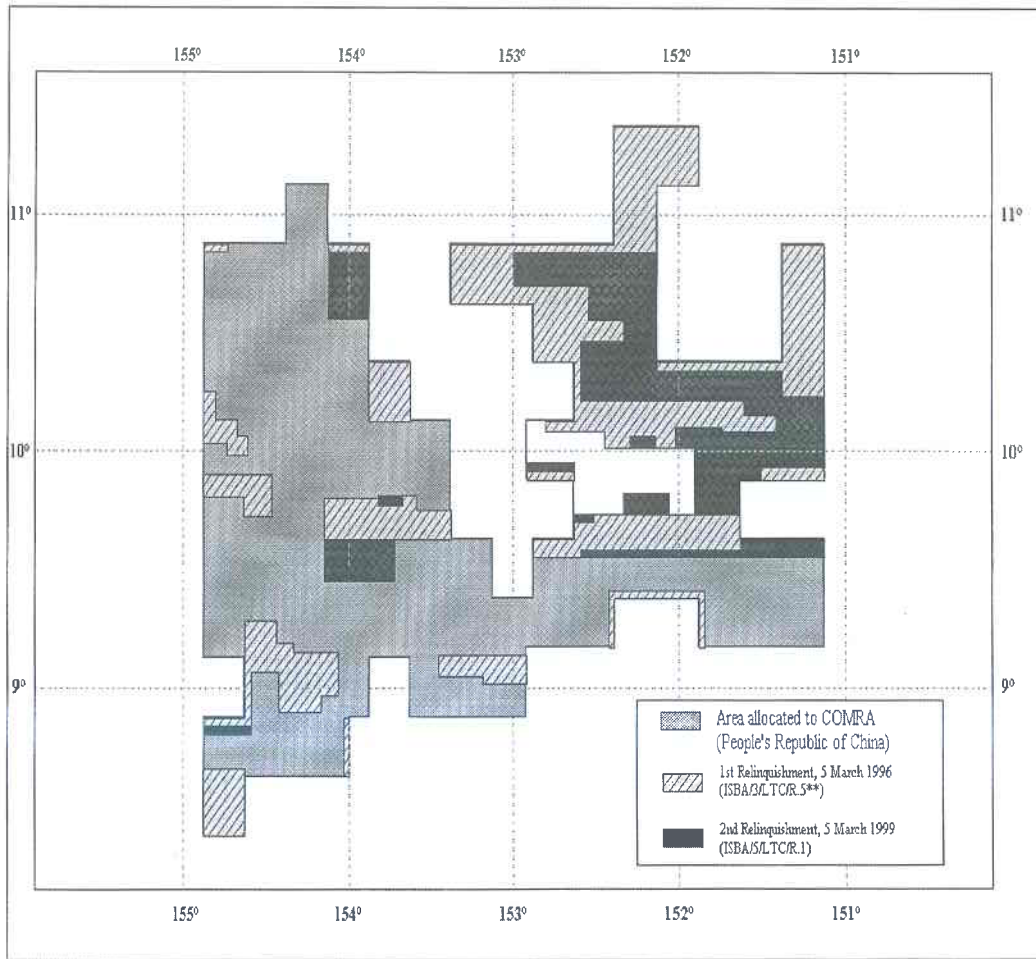

Figure 5 - Area allocated to COMRA (People's Republic of China)

### Part III

#### Documents, reports and other data relevant to the plan of work

14. The following are documents and reports of the Preparatory Commission relevant to the plan of work:

(a) Letter dated 17 August 1990 from the Chairman of the delegation of China addressed to the Chairman of the Preparatory Commission (LOS/PCN/112, 21 August 1990);

(b) Receipt of application from the Government of the People's Republic of China for registration of the China Ocean Mineral Resources Research and Development Association (COMRA) as a pioneer investor under resolution II of the Third United Nations Conference on the Law of the Sea. Note by the Secretary-General (LOS/PCN/113, 24 August 1990);

(c) Decision adopted by the General Committee of the Preparatory Commission concerning the application submitted by the People's Republic of China for registration as a pioneer investor (LOS/PCN/115, 30 August 1990);

(d) Report of the Group of Technical Experts to the General Committee of the Preparatory Commission on the application of the Government of the People's Republic of China for registration as a pioneer investor under resolution II (LOS/PCN/BUR/R.7, 23 January 1991);

(e) Decision adopted on 5 March 1991 by the General Committee of the Preparatory Commission concerning the application submitted by the People's Republic of China for registration as a pioneer investor (LOS/PCN/117, 7 March 1991 and Corr.1, 27 February 1991);

(f) Certificate of registration issued to COMRA as a pioneer investor dated 29 August 1991;

(g) Report on the status of the implementation of the obligations of the registered pioneer investors under resolution II and the related understandings. Prepared by the Secretariat (LOS/PCN/145, 23 September 1994);

15. The following documents and reports were submitted by COMRA to the Preparatory Commission both before and after registration:

(a) Periodic report on the activities of the China Ocean Mineral Resources Research and Development Association (COMRA) in the pioneer area (LOS/PCN/BUR/R.20, 2 March 1993);

(b) Explanation of the database diskette for the reserved area of the International Seabed Authority as required of the pioneer investor (LOS/PCN/BUR/R.21, 2 March 1993);

(c) Training programme for the Preparatory Commission of the International Seabed Authority as required of pioneer investors (LOS/PCN/TP/1993/CRP.13/Rev.1, 26 March 1993);

(d) Periodic report on the activities of the China Ocean Mineral Resources Research and Development Association (COMRA) in the pioneer area (LOS/PCN/BUR/R.33, 1 February 1994);

(e) Statement of the Chairman of the Preparatory Commission (LOS/PCN/L.114/Rev.1, paragraph 14, 8 March 1994);

(f) The China training programme: A progress report from the Chinese delegation (LOS/PCN/TP/1994/CRP.28, 2 August 1994);

(g) Statement by the Chairman of the Preparatory Commission (LOS/PCN/L.115/Rev.1, paragraph 8, 8 September 1994);

(h) Report on relinquishment of 30.05 per cent of the pioneer area. Submitted by China on 5 March 1996 (ISBA/3/LTC/R.5\*\*, 28 April 1998).\*

(i) Periodic report on the activities of the China Ocean Mineral Resources Research and Development Association (COMRA) in the pioneer area. Submitted by the delegation of China in March 1995 (ISBA/3/LTC/R.4, 24 June 1997 and Corr.1, 11 August 1997).\*

(j) Completion of the training programme approved by the Preparatory Commission, August 1995 (ISBA/3/LTC/R.6, 28 July 1997).\*

(k) Periodic report on the activities of China Ocean Mineral Resources Research and Development Association (COMRA) in the pioneer area for the period from 1995 to 1997 (ISBA/4/LTC/R.5).\*

(l) Periodic report on the activities of the China Ocean Mineral Resources Research and Development Association (COMRA) in the pioneer area for the period from 1 January to 31 December 1996. Submitted by the delegation of China in August 1998 (ISBA/4/LTC/R.6).\*

(m) Periodic report on the activities of the China Ocean Mineral Resources Research and Development Association (COMRA) in the pioneer area for the period from 1 January to 31 December 1997. Submitted by the delegation of China in August 1998 (ISBA/4/LTC/R.7).\*

\* The Preparatory Commission concluded its work upon entry into force of the Convention on November 16, 1994. Reports submitted by registered pioneer investors pursuant to resolution II after the Preparatory Commission concluded its work have been issued under the symbol "ISBA" as documents of the Legal and Technical Commission.

## Annex VI

### INTEROCEANMETAL JOINT ORGANIZATION

#### Part I

##### Information concerning the registered pioneer investor

1. Name of the registered pioneer investor: Interoceanmetal Joint Organization.
2. Address: 9, l.Cyryla I Metodego, 71-541 Szczecin, Poland.
3. Telephone number: (48) (91) 539 398.
4. Facsimile number: (48) (91) 539 399.
5. Electronic mail address: R.Kotlinski@iom.gov.pl.
6. Name of designated representative: Dr. Ryszard Kotlinski, Director-General, Interoceanmetal Joint Organization.
7. Place of registration: Szczecin, Poland.
8. Principal place of business: Szczecin, Poland.
9. Sponsoring States: Republic of Bulgaria, Republic of Cuba, Czech Republic, Republic of Poland, Russian Federation, Slovak Republic.
10. Dates of deposit of instrument of ratification of the 1982 United Nations Convention on the Law of the Sea:

Republic of Bulgaria	-	15 May 1996
Republic of Cuba	-	15 August 1984
Czech Republic	-	21 June 1996
Russian Federation	-	12 March 1997
Slovak Republic	-	8 May 1996

11. Date of consent to be bound by the Agreement relating to the Implementation of Part XI of the 1982 United Nations Convention on the Law of the Sea of 10 December 1982:

Republic of Bulgaria	-	15 May 1996
Republic of Cuba	-	bound under simplified procedure set out in article 5 of the Agreement
Czech Republic	-	21 June 1996
Russian Federation	-	12 March 1997
Slovak Republic	-	8 May 1996

12. A certificate of compliance was issued by the Preparatory Commission on 14 March 1995 in accordance with resolution II, paragraph 11(a) of the Third United Nations Conference for the Law of the Sea.

## Part II

Information relating to the area allocated to the registered pioneer investor

13. The area allocated to IOM is bounded by lines joining the following turning points, the coordinates of which are listed below:

### Sector B1

Turning points	Latitude (N)	Longitude (W)
1	13° 50'	120° 20'
2	14° 30'	120° 20'
3	14° 30'	120° 30'
4	15° 20'	120° 30'
5	15° 20'	120° 20'
6	15° 40'	120° 20'
7	15° 40'	119° 50'
8	16° 00'	119° 50'
9	16° 00'	120° 10'
10	16°30.790'	120° 10'
11	16°30.790'	119° 00'
12	15° 20'	119° 00'
13	15° 20'	118° 50'
14	15° 30'	118° 50'
15	15° 30'	119° 30'
16	15° 20'	119° 00'
1	13° 50'	120° 20'



## Sector B2

Turning points	Latitude (N)	Longitude (W)
1	8° 40'	120°30'
2	9° 30'	120°30'
3	9° 30'	122°22.410'
4	10° 40'	122°22. 410'
5	10° 30'	120° 00'
6	10° 45'	120° 00'
7	10° 45'	121° 30'
8	11° 00'	121° 00'
9	11° 00'	121° 10'
10	11° 20'	121° 10'
11	11° 20'	121° 40'
12	12° 00'	121° 40'
13	12° 00'	121° 10'
14	13° 20'	121° 10'
15	13° 20'	119° 50'
16	13° 10'	119° 50'
17	13° 20'	119° 50'
18	13° 10'	119° 50'
19	13° 10'	119° 25'
20	12° 20'	119° 25'
21	12° 20'	119° 50'
22	11° 50'	119° 50'
23	11° 50'	119° 25'
24	9° 45'	119° 25'
25	9° 45'	119° 00'
26	8° 50'	119° 00'
1	8° 40'	120° 30'

## Sector B3

1	7° 40'	123° 35'
2	8° 15'	123° 35'
3	8° 15'	124° 00'
4	9° 05'	124° 00'
5	9° 05'	122° 30'
6	9° 20'	122° 30'
7	9° 20'	121° 30'
8	8° 55'	121° 30'
9	8° 55'	122° 00'
10	8° 45'	122° 00'
11	8° 45'	122° 10'
12	8° 35'	122° 10'

Sector B3 Cont.)

Turning points	Latitude (N)	Longitude (W)
13	8° 35'	122° 45'
14	7° 40'	122° 45'
1	7° 40'	123° 35'

14. The general location of the area allocated to IOM and the areas subsequently relinquished by it are shown in figure 6.

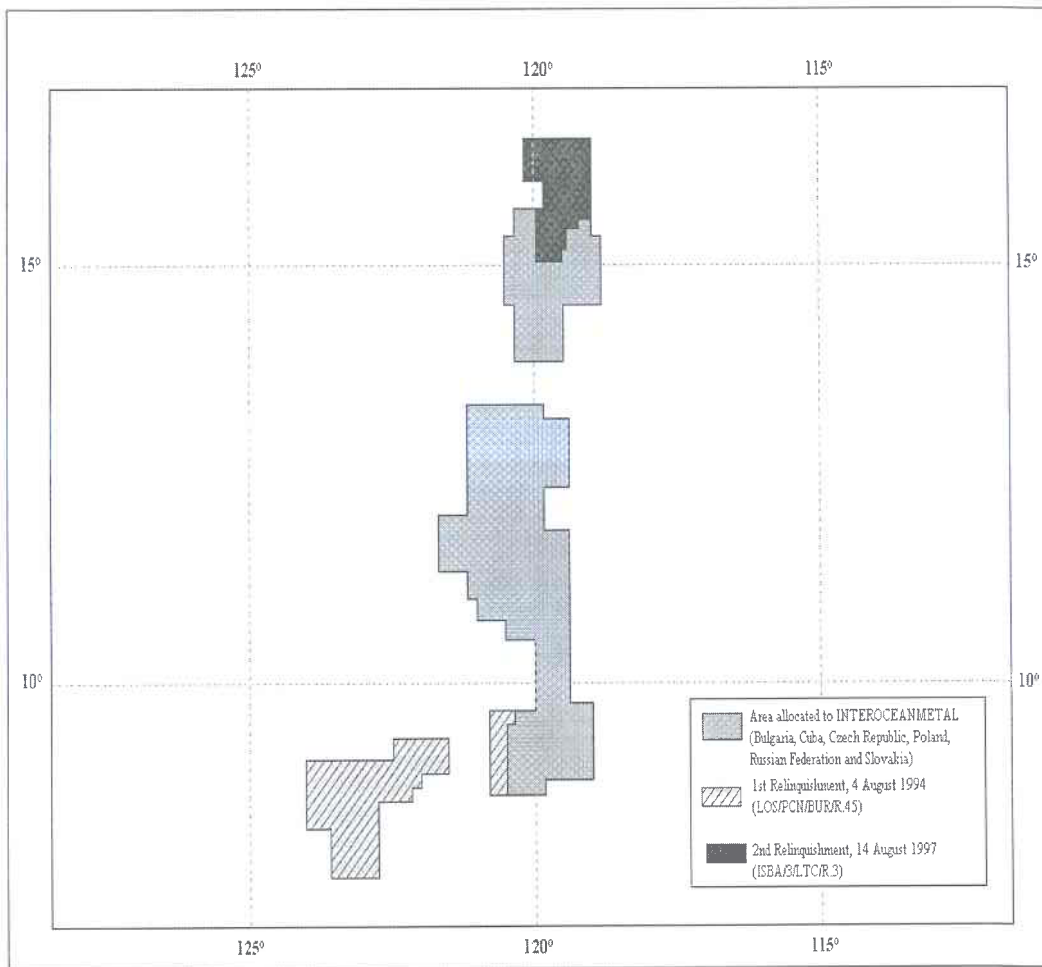

Figure 6 - Area allocated to Interoceanmetal Joint Organization

15. IOM relinquished 20.45 per cent of the area allocated to it on 4 August 1994 (LOS/PCN/BUR/R.45) and a further 10.6 per cent of the area on 14 August 1997 (ISBA/3/LTC/R.3). A further 18.95 per cent of the area is scheduled to be relinquished in 1999 - 2000.

### Part III

Documents, reports and other data relevant to the plan of work

16. The following are documents and reports of the Preparatory Commission relevant to the plan of work:

(a) Letter dated 20 December 1989 from the Permanent Representative of Poland to the United Nations addressed to the Special Representative of the Secretary-General for the Law of the Sea (LOS/PCN/109, 17 January 1990);

(b) Receipt of application from the Governments of the Republic of Bulgaria, the Republic of Cuba, the Czech and Slovak Federal Republic, the Republic of Poland and the Union of Soviet Socialist Republics for registration of the Interoceanmetal Joint Organization (IOM) as a pioneer investor under resolution II of the Third United Nations Conference on the Law of the Sea. Note by the Secretary-General (LOS/PCN/118, 13 March 1991);

(c) Decision adopted by the General Committee of the Preparatory Commission concerning the application submitted by the Republic of Bulgaria, the Republic of Cuba, the Czech and Slovak Federal Republic, the Republic of Poland and the Union of Soviet Socialist Republics for registration of the Interoceanmetal Joint Organization as a pioneer investor under resolution II of the Third United Nations Conference on the Law of the Sea (LOS/PCN/120, 21 March 1991);

(d) Report of the Group of Technical Experts to the General Committee of the Preparatory Commission on the application of the Governments of the Republic of Bulgaria, the Republic of Cuba, the Czech and Slovak Federal Republic, the Republic of Poland and the Union of Soviet Socialist Republics for registration as a pioneer investor under resolution II of the Third United Nations Conference on the Law of the Sea (LOS/PCN/BUR/R.8, 2 August 1991);

(e) Decision adopted on 21 August 1991 by the General Committee of the Preparatory Commission on the application submitted by the Governments of the Republic of Bulgaria, the Republic of Cuba, the Czech and Slovak Federal Republic, the Republic of Poland and the Union of Soviet Socialist Republics for registration of the Interoceanmetal Joint Organization (IOM) as a pioneer investor under resolution II of the Third United Nations Conference on the Law of the Sea (LOS/PCN/122, 22 August 1991);

(f) Certificate of registration issued to IOM as a pioneer investor dated 30 July 1992;

(g) Report on the status of the implementation of the obligations of the registered pioneer investors under resolution II and the related understandings. Prepared by the Secretariat (LOS/PCN/145, 23 September 1994).

17. The following documents and reports were submitted by IOM to the Preparatory Commission both before and after registration:

(a) Letter dated 27 June 1991 from the Director-General of the Interoceanmetal Joint Organization addressed to the Special Representative of the Secretary-General for the Law of the Sea concerning the application for registration of the Interoceanmetal Joint Organization as a pioneer investor under resolution II of the Third United Nations Conference on the Law of the Sea (LOS/PCN/118) (LOS/PCN/121, 6 August 1991);

(b) Training programme for the Preparatory Commission of the International Seabed Authority as required of pioneer investors. Proposal submitted by Interoceanmetal Joint Organization and its certifying States (LOS/PCN/TP/1993/CRP.12/Rev.1, 26 March 1993);

(c) Periodic report on the activities of the Interoceanmetal Joint Organization (IOM) and its certifying States in the pioneer area from August 1992 to July 1993. Submitted by the delegation of Poland (LOS/PCN/BUR/R.30, 2 September 1993);

(d) Periodic report on the activities of the Interoceanmetal Joint Organization (IOM) and its certifying States in the pioneer area from 1 July 1993 to 31 December 1993. Submitted by the delegation of Poland (LOS/PCN/BUR/R.39, 24 February 1994 and Corr.1, 23 May 1994);

(e) Letter dated 22 July 1994 from the Director General of the Interoceanmetal Joint Organization (IOM), on behalf of the Intergovernmental Council of IOM, addressed to the Chairman of the Preparatory Commission (LOS/PCN/BUR/R.46, 3 August 1994);

(f) Relinquishment of pioneer areas (LOS/PCN/BUR/R.45, 4 August 1994);

(g) Summary of the preliminary report on the reserved area for the Preparatory Commission for the International Seabed Authority and for the International Tribunal for the Law of the Sea (LOS/PCN/BUR/R.49, 31 August 1994);

(h) Periodic report on the activities of the Interoceanmetal Joint Organization (IOM) and its certifying States in the pioneer area from 1 January to 31 December 1994 (LOS/PCN/148, 7 March 1995);

(i) Information on the implementation of the training programme for the Preparatory Commission. Submitted by the Interoceanmetal Joint Organization and its certifying States (LOS/PCN/149, 7 March 1995);

(j) Letter dated 6 March 1996 from the Director-General of the Interoceanmetal Joint Organization to the Chairman of the Assembly of the International Seabed Authority and the accompanying documents:

- (i) Report on a training course prepared by the Interoceanmetal Joint Organization for four trainees of the International Seabed Authority;
- (ii) Reports on training prepared by the trainees;
- (iii) A scientific report "Geophysical methods for exploration of polymetallic nodules" prepared by the trainees in English;
- (iv) A scientific report on the processing of the polymetallic nodules, prepared by a trainee in Russian.

(k) Report on the relinquishment of 10 per cent of the Interoceanmetal Joint Organization pioneer area under resolution II of the Third United Nations Conference on the Law of the Sea. Submitted by the Interoceanmetal Joint Organization (ISBA/3/LTC/R.3, 14 August 1997);\*

(l) Periodic report on the activities of the Interoceanmetal Joint Organization (IOM) in the pioneer area from 1 January to 31 December 1995 (ISBA/3/LTC/R.9, 22 August 1997);\*

(m) Periodic report on the activities of the Interoceanmetal Joint Organization (IOM) in the pioneer area from 1 January to 31 December 1996 (ISBA/3/LTC/R.10, 22 August 1997);\*

(n) Periodic report on the activities of the Interoceanmetal Joint Organization (IOM) in the pioneer area from 1 January to 31 December 1997 (ISBA/4/LTC/R.2, 1 April 1998).\*

---

\* The Preparatory Commission concluded its work upon entry into force of the Convention on November 16, 1994. Reports submitted by registered pioneer investors pursuant to resolution II after the Preparatory Commission concluded its work have been issued under the symbol "ISBA" as documents of the Legal and Technical Commission.

## **Annex VII**

### REPUBLIC OF KOREA

#### **Part I**

##### **Information concerning the registered pioneer investor**

1. Name of the registered pioneer investor: The Ministry of Maritime Affairs and Fisheries, The Government of the Republic of Korea.
2. Address: The Ministry of Maritime Affairs and Fisheries, The Government of the Republic of Korea, Jinsol BLDG, 826-14, Yoksam-dong, Gangnam-gu, Seoul, 135-080, Republic of Korea.
3. Telephone number: (82) (2) 554 2331.
4. Facsimile number: (82) (2) 554 2425.
5. Name of designated representative: Sun-Kil Kim, Minister, the Ministry of Maritime Affairs and Fisheries, The Government of the Republic of Korea
6. Sponsoring State: The Republic of Korea.
7. Date of deposit of instrument of ratification of the 1982 United Nations Convention on the Law of the Sea and of consent to be bound by the Agreement relating to the Implementation of Part XI of the 1982 United Nations Convention on the Law of the Sea of 10 December 1982: 29 January 1996.
8. In the case of the Republic of Korea which was not able to obtain a certificate of compliance before the Preparatory Commission concluded its work, a statement describing the status of the implementation of the obligations of the registered pioneer investor was issued in lieu of the certificate of compliance (ISBA/3/C/6).

## Part II

### Information relating to the area allocated to the registered pioneer investor

9. The area allocated to the Republic of Korea is bounded by lines joining the following turning points, the coordinates of which are listed below:

Sector A2		
Turning points	Latitude (N)	Longitude (W)
A2-1	11° 30.00'	136° 00.00'
A2-2	11° 30.00'	135° 00.00'
A2-3	10° 20.00'	135° 00.00'
A2-4	10° 20.00'	135° 20.00'
A2-5	10° 00.00'	135° 20.00'
A2-6	10° 00.00'	135° 30.00'
A2-7	9° 40.00'	135° 30.00'
A2-8	9° 40.00'	136° 00.00'
A2-1	11° 30.00'	136° 00.00'
Sector B1		
B1-1	11° 30.00'	134° 30.00'
B1-2	11° 30.00'	133° 40.00'
B1-3	11° 00.00'	133° 40.00'
B1-4	11° 00.00'	133° 30.00'
B1-5	10° 30.00'	133° 30.00'
B1-6	10° 30.00'	133° 00.00'
B1-7	10° 02.35'	133° 00.00'
B1-8	10° 02.35'	132° 50.00'
B1-9	9° 30.00'	132° 50.00'
B1-10	9° 30.00'	133° 50.00'
B1-11	10° 20.00'	133° 50.00'
B1-12	10° 20.00'	134° 30.00'
B1-1	11° 30.00'	134° 30.00'
Sector B2		
B2-1	10° 30.00'	133° 00.00'
B2-2	10° 30.00'	132° 30.00'
B2-3	11° 00.00'	132° 30.00'
B2-4	11° 00.00'	131° 30.00'
B2-5	11° 30.00'	131° 30.00'
B2-6	11° 30.00'	131° 10.00'
B2-7	11° 40.00'	131° 10.00'
B2-8	11° 40.00'	130° 30.00'
B2-9	9° 40.00'	130° 30.00'

## Sector B2 Cont.)

Turning points	Latitude (N)	Longitude (W)
B2-10	9° 40.00'	131° 00.00'
B2-11	9° 10.00'	131° 00.00'
B2-12	9° 10.00'	131° 30.00'
B2-13	9° 00.00'	131° 30.00'
B2-14	9° 00.00'	131° 55.00'
B2-15	9° 30.00'	131° 55.00'
B2-16	9° 30.00'	132° 50.00'
B2-17	10° 02.35'	132° 50.00'
B2-18	10° 02.35'	133° 00.00'
B2-1	10° 30.00'	133° 00.00'

## Sector C1

C1-1	11° 40.00'	129° 45.00'
C1-2	11° 40.00'	129° 00.00'
C1-3	11° 25.00'	129° 00.00'
C1-4	11° 25.00'	128° 30.00'
C1-5	11° 35.00'	128° 30.00'
C1-6	11° 35.00'	128° 07.00'
C1-7	11° 05.00'	128° 07.00'
C1-8	11° 05.00'	128° 50.00'
C1-9	10° 32.32'	128° 50.00'
C1-10	10° 32.32'	129° 00.60'
C1-11	10° 15.00'	129° 00.60'
C1-12	10° 15.00'	129° 45.00'
C1-1	11° 40.00'	129° 45.00'

## Sector N1

N1-1	16° 40.00'	133° 40.00'
N1-2	16° 40.00'	133° 00.00'
N1-3	16° 50.00'	133° 00.00'
N1-4	16° 50.00'	132° 40.00'
N1-5	16° 30.00'	132° 40.00'
N1-6	16° 30.00'	131° 20.00'
N1-7	16° 50.00'	131° 20.00'
N1-8	16° 50.00'	131° 00.00'
N1-9	16° 40.00'	131° 00.00'
N1-10	16° 40.00'	130° 15.00'
N1-11	16° 25.00'	130° 15.00'
N1-12	16° 25.00'	130° 10.00'
N1-13	16° 00.00'	130° 10.00'
N1-14	16° 00.00'	130° 50.00'
N1-15	16° 00.10'	130° 50.00'



## Sector N1 Cont.)

Turning points	Latitude (N)	Longitude (W)
N1-16	16° 00.10'	131° 50.00'
N1-17	16° 00.00'	131° 50.00'
N1-18	16° 00.00'	132° 10.00'
N1-19	16° 00.10'	132° 10.00'
N1-20	16° 00.10'	133° 00.00'
N1-21	16° 00.15'	133° 00.00'
N1-22	16° 00.15'	133° 10.00'
N1-23	16° 20.00'	133° 10.00'
N1-24	16° 20.00'	133° 30.00'
N1-25	16° 25.00'	133° 30.00'
N1-26	16° 25.00'	133° 40.00'
N1-1	16° 40.00'	133° 40.00'

## Sector N3

N3-1	17° 10.00'	126° 00.00'
N3-2	17° 10.00'	125° 40.00'
N3-3	16° 50.00'	125° 40.00'
N3-4	16° 50.00'	125° 00.00'
N3-5	16° 14.00'	125° 00.00'
N3-6	16° 14.00'	125° 20.00'
N3-7	15° 44.00'	125° 20.00'
N3-8	15° 44.00'	126° 30.00'
N3-9	16° 00.00'	126° 30.00'
N3-10	16° 00.00'	126° 45.00'
N3-11	16° 15.00'	126° 45.00'
N3-12	16° 15.00'	126° 10.00'
N3-13	16° 45.15'	126° 10.00'
N3-14	16° 45.15'	126° 00.00'
N3-1	17° 10.00'	126° 00.00'

10. The general location of the area allocated to the Republic of Korea and the areas subsequently relinquished by it are shown in figure 7.

11. The Republic of Korea relinquished 20.01 per cent of its pioneer area on 30 July 1997 (ISBA/3/LTC/R.8). An additional 10 per cent is scheduled to be relinquished by 2 August 1999 and an additional 20 per cent will be relinquished after the end of the eighth year from the date of allocation of the area or the date of the award of a production authorization, whichever is earlier.

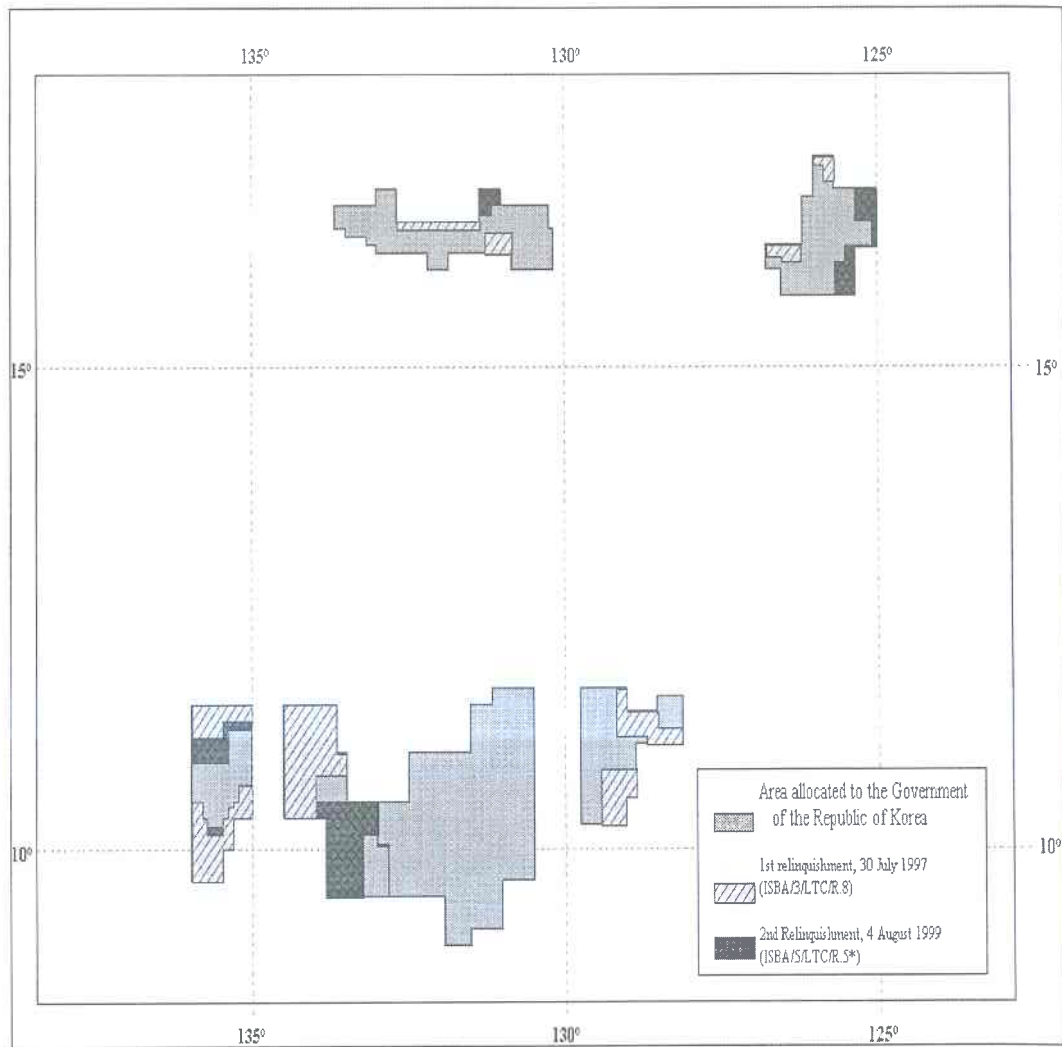

Figure 7 - Area allocated to Republic of Korea

### Part III

#### Documents, reports and other data relevant to the plan of work

12. The following are documents and reports of the Preparatory Commission relevant to the plan of work:

(a) Receipt of application from the Government of the Republic of Korea for registration as a pioneer investor under resolution II of the Third United Nations Conference on the Law of the Sea. Note by the Secretary-General (LOS/PCN/134, 20 January 1994);

(b) Decision adopted by the General Committee on behalf of the Preparatory Commission concerning the application submitted by the Government of the Republic of Korea for registration as a pioneer investor under resolution II of the Third United Nations Conference on the Law of the Sea (LOS/PCN/135, 8 February 1994);

(c) Report of the Group of Technical Experts to the General Committee of the Preparatory Commission on the application of the Government of the Republic of Korea for registration as a pioneer investor under resolution II of the Third United Nations Conference on the Law of the Sea (LOS/PCN/BUR/R.40, 25 July 1994);

(d) Decision adopted on 2 August 1994 by the General Committee of the Preparatory Commission on the application submitted by the Government of the Republic of Korea for registration as a pioneer investor under resolution II of the Third United Nations Conference on the Law of the Sea (LOS/PCN/144, 12 October 1994);

(e) Statement describing the status of the implementation of the obligations of the registered pioneer investor, the Government of the Republic of Korea, under resolution II and the related understanding adopted by the General Committee on 12 August 1994 (ISBA/3/C/6, 12 August 1997).

13. The following documents and reports were submitted by the Republic of Korea to the Preparatory Commission both before and after registration:

(a) Training programme for the International Seabed Authority as required of pioneer investors (LOS/PCN/150, 6 March 1995);\*

(b) Periodic report on the activities of the Republic of Korea in the pioneer area for the period from 2 August 1994 to 31 July 1996 (ISBA/3/LTC/R.1, 10 March 1997);\*

(c) Explanation of the database diskette for the reserved area of the International Seabed Authority, as required of the pioneer investor (ISBA/3/LTC/R.2, 10 March 1997);\*

(d) Training programme for the International Seabed Authority as required of pioneer investors (ISBA/3/LTC/2, 23 June 1997);\*

(e) Periodic report on the activities of the Republic of Korea in the pioneer area from 1 August 1996 to 31 July 1997. Submitted by the delegation of the Republic of Korea on 30 July 1997 (ISBA/3/LTC/R.7, 12 August 1997);\*

(f) Report on relinquishment of pioneer areas. Submitted by the delegation of the Republic of Korea on 30 July 1997 (ISBA/3/LTC/R.8, 12 August 1997); \*

(g) Periodic report on the activities of the Republic of Korea in the pioneer area for the period from 1 August 1997 to 31 July 1998 (ISBA/4/LTC/R.4).\*

---

\* The Preparatory Commission concluded its work upon entry into force of the Convention on 16 November 1994. Reports submitted by registered pioneer investors pursuant to resolution II after the Preparatory Commission concluded its work have been issued under the symbol "ISBA" as documents of the Legal and Technical Commission.



## Appendix B

### **POLYDAT: Polymetallic nodule database for areas reserved for the conduct of activities by the International Seabed Authority in areas beyond the limits of national jurisdiction (“The Area”)**

#### INTRODUCTION

1. POLYDAT, the database on polymetallic nodules for reserved areas was established based on a recommendation by the Group of Technical Experts of the Preparatory Commission. In 1992, the Group of Technical Experts (GTE) of the Preparatory Commission for the International Seabed Authority and for the International Tribunal for the Law of the Sea was convened to review and evaluate a joint report carrying the rubric “Preparatory Work in the International Seabed Authority’s Reserved Area – August 1991”. This report was prepared by the registered pioneer investors, France, Japan and the Russian Federation, in accordance with the Understanding on the Fulfillment of Obligations by the Registered Pioneer Investors and their **Certifying States** (LDS/PDN/L.87, annex, para 7). The Group of Technical Experts was convened to make a detailed examination of the documents submitted by the three pioneer investors, to determine if the objective of the preparatory work as contained in document LDS/PCN/BUR/R.5 had been fully met.

2. The objective of the preparatory work was to compile and illustrate all the existing data in the areas reserved for the conduct of activities by the International Seabed Authority in the central region of the Clarion-Clipperton fracture zone in order to facilitate detailed planning and implementation of Stage I of the exploration plan. The Group of Technical Experts envisaged that the data would be compiled from a variety of sources. These would include data submitted by the registered pioneer investors and additional data collected by individual pioneer investors in areas that were not part of the specific areas covered in their respective applications.

3. The Group of Technical Experts recalled these needs, as well as the need to establish a comprehensive database for sample stations, to compile bathymetric information of all areas including information compiled by such means as precision depth recorders and multi-beam echosounders, and relevant information on nodule distribution, small scale features and other information from photography and multi-frequency exploration systems.
4. The Group of Technical Experts concluded following its detailed examination of the documents submitted by the three pioneer investors that the objective of the preparatory work had been fully met. It also recommended that the Secretariat acquire the hardware and software to establish the comprehensive database.
5. POLYDAT has since been expanded to encompass all reserved areas in the Clarion-Clipperton fracture zone as well as the reserved area in the central Indian Ocean basin. The data contained in POLYDAT are those on reserved areas that were submitted at the time of registration.
6. In accordance with the expressed needs identified by the Group of Technical Experts, the outputs of POLYDAT have been geared to include:
  - (a) Base maps (Index maps, bathymetric maps, metal content maps, abundance maps and metal accumulation maps); and
  - (b) Interpreted maps
7. POLYDAT is also the basis upon which resource assessments of reserved areas will be conducted.

#### **NATURE OF THE DATA IN POLYDAT**

8. The data submitted by the pioneer investors are of three different kinds :
  - Co-ordinates of the areas
  - Methodology and equipment used by the pioneer investors for data acquisition and analysis
  - Mining data

#### **Origins of the data**

9. The data came from different sources that can be grouped as follows :

- Data submitted by the first group of pioneer investors (France – IFREMER/AFERNOD), Japan (DORD), India (DOD), and the Russian Federation (Yuzhmorgeologiya). The French, Japanese and Russian data concern the North Pacific Ocean while the Indian data concerns the central Indian ocean basin.
- Data submitted by IFREMER/AFERNOD, DORD and Yuzhmorgeologiya in their joint report on the area reserved for the Authority in the central region of the north-east Pacific ocean, which have been compared and for which an adjustment has been made on the French data on abundance.
- Data submitted by China (COMRA) for areas in the north Pacific ocean.
- Data submitted by Inter Ocean Metal Joint Organization (IOM) for areas in the north Pacific ocean.
- Data submitted by the Republic of Korea for areas in the north Pacific ocean.

#### **Co-ordinates of the areas**

10. It should be noted that the coordinates of the different areas that have been presented in the applications of the pioneer investors were originally strictly confidential. During the process of registration, these areas have been either allocated to the pioneer or reserved for the Authority. The coordinates of the areas have then been published and are no longer confidential.

#### **Methodology and equipment used by the pioneers for data acquisition**

11. The pioneer investors provided, with their application, general information on the methods and equipment that have been used to acquire and process the data. This information constitutes an indispensable reference for the correct interpretation of mining data.

12. A link between individual mining data and the methods and equipment used for their acquisition and analysis must be maintained. As different methodologies and equipment are used, the data may be subject to discrepancies and some adjustment may be necessary.



## Mining data

13. Mining data has been provided by all the pioneer investors and consist of information acquired at a geographical point defined by a serial number and its co-ordinates (latitude and longitude), namely the depth of the ocean bottom, the abundance of nodules and their metal contents.

## DATABASE STRUCTURE

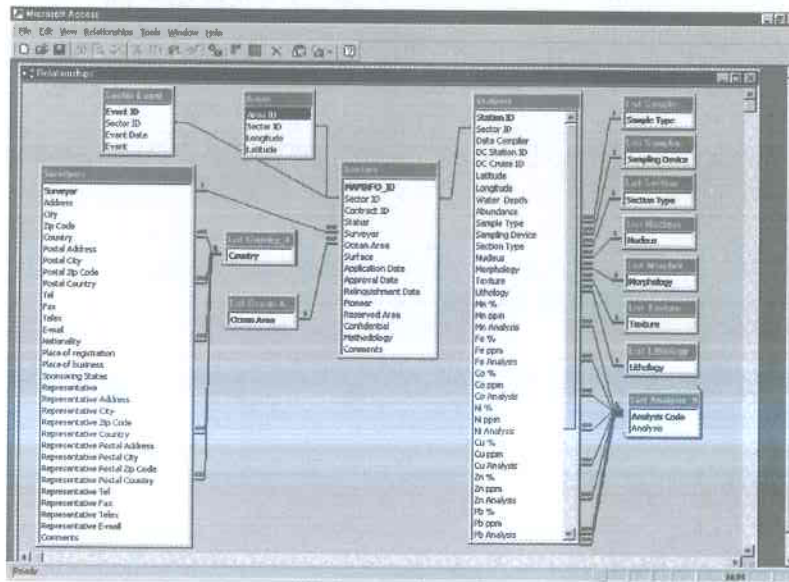

## Data Model

14. The data model derived from the Data Analysis is presented below using the entity-Relationship formalism. It illustrates the entities (tables) and the relations between them.

15. There are 4 main tables :

- Sectors
- Sector event
- Stations
- Surveyor

16. The other tables prefixed by "list" are lookup tables used to enforce data integrity in the core table. Tables are linked by appropriate relevant key fields.

## Details of the tables

### Sector Table

FIELD NAME	TYPE	SIZE	DESCRIPTION
Sector_ID	Text	50	Sector Identifier
Mapinfo_id	Long	4	MapInfo Internal Identifier link to geographic object
Contract_ID	Text	50	Contract Identifier (eg. Contract Number)
Status	Text	12	Status for the Area (Prospecting, Exploration, Extension)
Surveyor	Text	50	Organization identifier
Ocean Area	Text	50	Name of the Ocean area where is the Area
Surface	Double	8	Surface of the Area in sqkm
Application_date	Date/Time	8	Date of Application
Approval_date	Date/Time	8	Date of Authorization
Relinquishment_date	Date/Time	8	Date of Relinquishment
Pioneer	Yes/No	1	Pioneer Area
Reserved Area	Yes/No	1	Reserved Area
Confidential	Yes/No	1	Confidentiality (Yes/No)
Methodology	Memo	0	Methodology of Extraction and exploration
Comments	Memo	0	General Comments

17. The Sector Table describes the different reserved areas which fall into the following categories:

- Prospecting
- Exploration Area applied
- Exploration Area after first Relinquishment
- Exploration Area after second Relinquishment
- Exploration Area after third Relinquishment
- Exploitation Area

18. Each area will be defined by the list of co-ordinates submitted to the Authority in an application and after each relinquishment. The default co-ordinates system is geodesic co-ordinates referenced by the *World Geodetic System of 1984 (WGS84)*.

19. The Stations Table records information about each sample or group of samples taken during prospecting or exploration of the reserved areas.

### Stations Table

FIELD NAME	TYPE	SIZE	DESCRIPTION
Station_ID	Text	50	ISA Station Identifier
MapInfo_id	Long	4	MapInfo Internal ID linked to geographic object
Sector_id	Text	50	Sector identifier
Data Compiler	Texte	50	Organization compiling the data
DC_Station_ID	Text	50	Data Compiler Station Identifier
DC_Cruise_ID	Text	50	Data Compiler Cruise Identifier if any
Latitude	Double	8	Latitude of the sample (WGS84)
Longitude	Double	8	Longitude of the sample (WGS84)
Water_Dept	Double	8	Depth of the sampling collection (WGS84 spheroid)
Abundance	Double	8	Abundance of minerals in kg/sqm
Sample_type	Text	50	Sample type
Sampling_device	Text	50	Sampling Device
Section_type	Text	100	Section Type
Nucleus	Text	50	Nucleus
Morphology	Text	50	Morphology
Texture	Text	50	Texture
Lithology	Text	50	Lithology of the seabed
Mn%	Double	8	Manganese percentage
Mn_ppm	Double	8	Manganese parts per million
Mn_Analysis	Text	2	Manganese analysis method
Fe_%	Double	8	Iron percentage
Fe_ppm	Double	8	Iron parts per million
Fe_Analysis	Text	2	Iron analysis method
Co%	Double	8	Cobalt percentage
Co_ppm	Double	8	Cobalt parts per million

Co_Analysis	Text	2	Cobalt analysis method
Ni%	Double	8	Nickel percentage
Ni_ppm	Double	8	Nickel parts per million
Ni_Analysis	Text	2	Nickel analysis method
Cu%	Double	8	Copper percentage
Cu_ppm	Double	8	Copper parts per million
Cu_Analysis	Text	2	Copper analysis method
Zn%	Double	8	Zinc percentage
Zn_ppm	Double	8	Zinc parts per million
Zn_Analysis	Text	2	Zinc analysis method
Pb%	Double	8	Lead percentage
Pb_ppm	Double	8	Lead parts per million
Pb_Analysis	Text	2	Lead analysis method
Al%	Double	8	Aluminum percentage
Al_ppm	Double	8	Aluminum parts per million
Al_Analysis	Text	2	Aluminum analysis method
Si%	Double	8	Silicon percentage
Si_ppm	Double	8	Silicon parts per million
Si_Analysis	Text	2	Silicon analysis method
Ca%	Double	8	Calcium percentage
Ca_ppm	Double	8	Calcium parts per million
Ca_Analysis	Text	2	Calcium analysis methods
Water_loss	Double	8	Water loss in percentage
Confidential	Yes/No	1	Confidentiality of data
Comments	Memo	0	General Comments

20. The Surveyor Table records information about the prospector or explorer as specified in Annex 1 and Annex 2 of the Mining Code (ISBA/LTC/WP.1/Rev.1)

### Surveyor Table

FIELD NAME	TYPE	SIZE	DESCRIPTION
Surveyor	Text	50	Surveyor Name
Address	Text	255	Surveyor Address
City	Text	50	Surveyor City
Zip Code	Text	50	Surveyor Zip Code
Country	Text	50	Surveyor Country
Postal Address	Text	255	Surveyor Postal Address (if different from the above)

FIELD NAME	TYPE	SIZE	DESCRIPTION
Postal City	Text	50	Surveyor Postal City (if different from the above)
Postal Zip Code	Text	50	Surveyor Postal Zip Code (if different from the above)
Postal Country	Text	100	Surveyor Postal Country (if different from the above)
Tel	Text	50	Surveyor phone number
Fax	Text	50	Surveyor fax number
Telex	Text	50	Surveyor telex
E-mail	Text	200	Surveyor e-mail
Nationality	Text	100	Nationality of the applicant
Place of registration	Text	255	Place of registration if the Surveyor is a juridical person
Place of business	Text	255	Place of business if the Surveyor is a juridical person
Sponsoring states	Text	200	States sponsoring the Surveyor for exploration or exploitation
Representative	Text	50	Surveyor designated representative (if different from the above)
Representative_Address	Text	255	Representative Address
Representative_City	Text	50	Representative City
Representative_Zip	Text	50	Representative Zip Code
Representative_Country	Text	100	Representative Country
Representative_Postal_Address	Text	255	Representative Postal Address
Representative_Postal_City	Text	50	Representative City
Representative_Postal_Zip_code	Text	50	Representative Zip Code
Representative_Postal_country	Text	100	Representative Country
Representative_Tel	Text	50	Representative Phone Number
Representative_fax	Text	50	Representative Fax
Representative_Telex	Text	50	Representative Telex
Representative_E-mail	Text	200	Representative E-mail
Comments	Memo	0	Comments

21. The Sector Event table describes events associated with the management of the application, such as reception of reports, confirmation letters, reception of data and reception of various documents.

## Sector Event

FIELD NAME	TYPE	SIZE	DESCRIPTION
Event_ID	Long	4	Sector Identifier
Sector_ID	Text	50	Date of the Event
Event_date	Date/Time	8	Description of the Event
Event	Memo	0	Description of the event

## Lookup Tables

TABLE NAME	DESCRIPTION
List Analysis	Analysis Code/ Analysis Method
List Country	Country name
List Lithology	Lithology of the seabed
List Morphology	Morphology of the sample
List Nucleus	Nucleus Type
List Ocean Area	Ocean Area Name
List Sample Type	Sample Type Name
List Sampling Device	Sampling Device
List Section Type	Section Type of the Nodule
List Texture	Texture of the sample

22. The lookup tables are based on the National Geographic Data Center (NGDC) which is an extension of the codification used by the Scripps Institute of Oceanography(SIO).

## OUTPUTS FROM THE POLYDAT

23. Polydat used in conjunction with MapInfo and Excel generate 3 types of outputs :
- maps,
  - listings and
  - graphs.

### Maps :

- Maps of the perimeter of different areas;
- Index maps illustrating the location of all sample stations and track lines;
- Bathymetric and topographic maps of specific areas;
- Grade maps showing the metal content;
- Abundance maps;
- Accumulation maps (composite of metal and abundance), and

- A series of interpreted maps that could serve as a basis for the preliminary identification of those parts of the area that might be of a particular interest.

### Listings and graphs

24. Polydat also allows the production of different kinds of listings or graphs, including:
- Listings of co-ordinates of the points delimiting a particular area including areas relinquished by pioneer investors,
  - Results of calculations of the surface area of a particular sector,
  - Listings of mining data in a particular area
  - Results of the statistical analysis of one or several data parameters (depth, abundance, metal content) in a particular area (minimum, maximum, number of data, average, standard deviation, variance, etc...)
  - Results of the calculation of metal accumulations (abundance \* metal content) and statistics on metal accumulations,
  - Result of the estimation of total tonnage of nodules and contained metals in a particular area, and
  - Graphical representations of the statistical distributions of different parameters in a given area (histograms, frequency curves and ascending or descending cumulative frequency curves, etc...)



International Seabed Authority, 14-20 Port Royal Street, Kingston, Jamaica  
<http://www.isa.org.jm>

ISBN 976-610-311-9



9 789766 103118